





Digital Pressure Gauge, High Precision

Model: MXP



PRODUCT DESCRIPTION

▼
Accuracy up to 0.025% F.S., ideal for instrument calibration

▼
Regulated by the equipment from international, industry-leading calibration companies: Mensor and GE

▼
Built-in lithium battery, which allows charging during use (Micro-B)

PRODUCT SPECIFICATION

Nominal size

4"

Scale ranges

0 ... 40 kPa to 0 ... 100 MPa, or other equivalent units of pressure, vacuum or compound

Pressure units

kg/cm², mH₂O, kPa, mmHg, psi, bar, pa, MPa
(Up to 8 units can be switched, if not specified, the engineer will select it according to the pressure range)

Accuracy

±0.1% F.S.,
±0.05% F.S.,
±0.025% F.S.

Process connection

304 SS
1/2, 1/8, 1/4, 3/8, 1/2
NPT, G

Case/Ring

Aluminum alloy nickel plating

Panel

PVC

Diaphragm

316L SS

Medium temperature

-20°C ... 60°C

Display

5.5 digits
LCD, switchable backlight button

Response time

20 ... 25 times/sec

Power supply

14500 rechargeable lithium battery, Micro-B charging port

Weight

1.5 kg
(including the box and accessories)charging port

The product images displayed in the catalog are illustrative, and the actual products will be customized to your requirements.

ACCESSORIES



▼ Accessories
Shake-proof box
size: 200mm*140mm*100mm



▼ Accessories
Accessory kits: charger, charging cable

DIMENSIONS

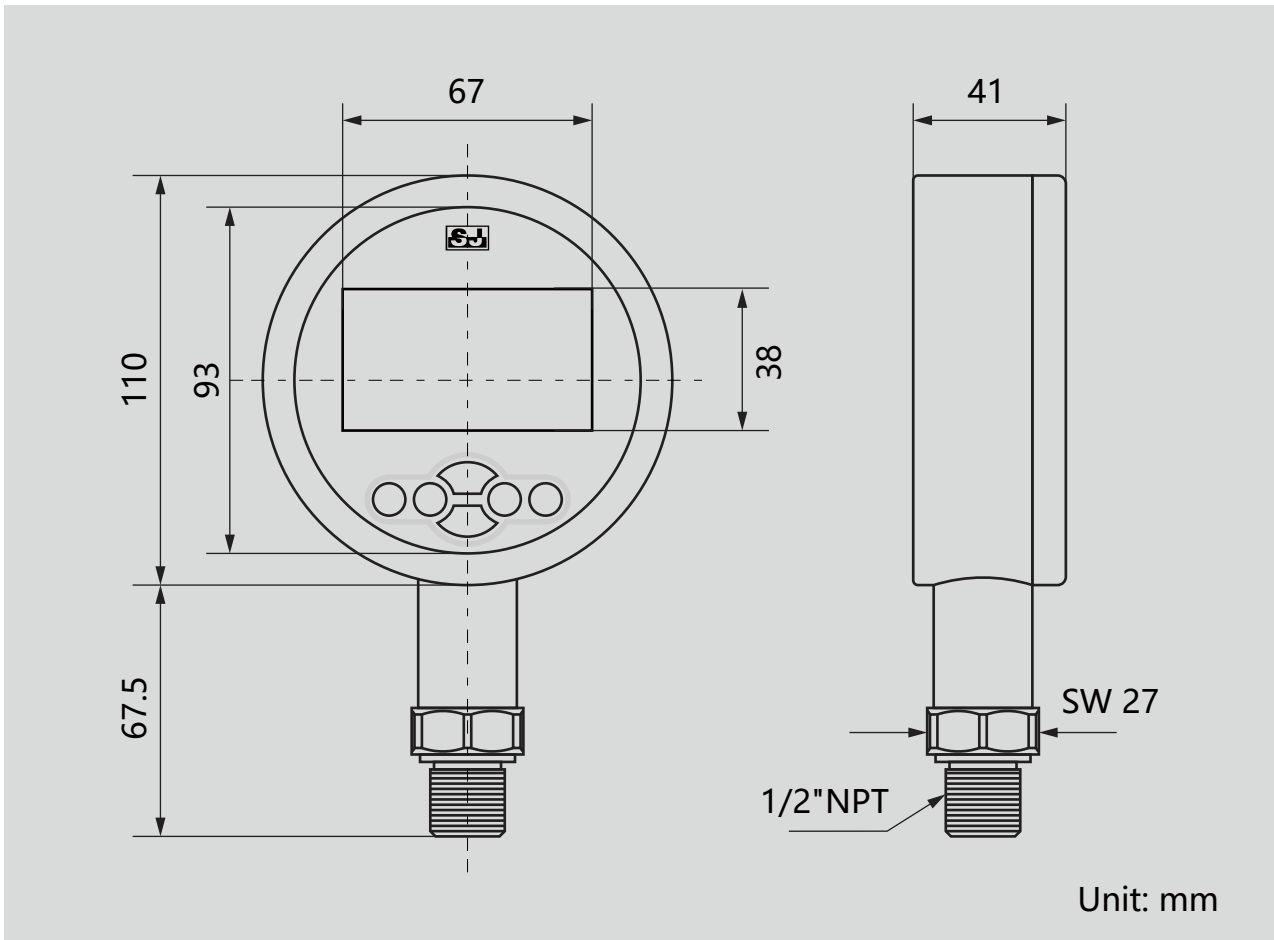



rsIMMA

Elementos For Manufacturing Purposes



MEXICO BRANCH OFFICE

Roberto Diaz No. 401
Ciudad Industrial
Aguascalientes, Ags.
México
20290

4ManPro@4ManPro.com
+52 (449) 171 3420
www.4ManPro.com/SPA/



USA BRANCH OFFICE

708 Main St.
10th Floor
Houston, Tx, USA
77002

4ManPro_USA@4ManPro.com
+1 (832) 871 5022
www.4ManPro.com/ENG/