





Product introduction

Description



High performance pressure transmitter

MSSMP131 compact pressure transmitter combined with all the latest available technologies of the modern electronic pressure measurement fields. It's the most cost-effective products after 10 year's research and development. The sensor adopts full-automatic linear and temperature compensation technology to ensure the efficiency and quality of mass production. Fully-sealed and isolated air cavity design to ensure the long term reliability. Signal transmitting module adopts original calibration technology to realize parameters setting easily without any tools. MSSMP131 compact pressure transmitter has unique technological advantage which is different from other ordinary products with the same price and its' capabilities are equivalent to the most of the high-end products, which is the first selection of the most cost-effective products.

Main parameters

Pressure types	Differential pressure
Measuring range	10kPa-3.5MPa, please refer to the ordering information chapter
Output signal	4-20mA, 4-20mA+HART, 0.5-4.5VDC, Modbus-RTU/RS485, others
Reference accuracy	±0.2% URL, ±0.5% URL, optional ±0.1% URL

Field of application

Pressure, differential pressure and level measurement

Approvals



Measuring medium

The fluid which compatible with wetted parts



Technical specifications

Measuring range and limit

Nominal value	Smallest calibratable span	Lower range limit(LRL)	Upper range limit (URL)	High pressure side overload limit	Low pressure side overload limit
35kPa	10kPa	-35kPa	35kPa	70kPa	35kPa
70kPa	35kPa	-70kPa	70kPa	150kPa	70kPa
100kPa	50kPa	-100kPa	100kPa	200kPa	100kPa
200kPa	100kPa	-200kPa	200kPa	400kPa	200kPa
350kPa	200kPa	-350kPa	350kPa	700kPa	350kPa
700kPa	350kPa	-500kPa	700kPa	1400kPa	700kPa
1MPa	500kPa	-0.5MPa	1MPa	2MPa	1MPa
2MPa	1MPa	-0.5MPa	2MPa	4MPa	1MPa
3.5MPa	1.7MPa	-0.5MPa	3.5MPa	7MPa	1MPa

Above measurement range can be replaced by kg/cm², MPa and kPa units .Which can provide other measurement range according to the requirements. Adjust requirements: lower range value (LRV) and upper range value (URV) can be adjusted within the scope of the upper and lower range limit, smallest calibratable span ≤ | URV-LRV | ≤ upper range limit

Reference accuracy

Including linearity, hysteresis and repeatability. calibration temperature: 20°C ± 5°C

Linear output accuracy	Typical	±0.2%URL (HART output accuracy: ±0.1% URL)	Nominal value: 35kPa, 70kPa, 100kPa, 200kPa, 350kPa, 700kPa, 1MPa, 2MPa, 3.5MPa
	Max/Voltage output	±0.5% URL	

Standard specifications and reference conditions

Test standard: GB/T28474 / IEC60770; Zero based-calibration span, Linear output, Silicon oil filling, 316L stainless steel isolation diaphragm.

Power supply effects

Zero and span change should not be more than ± 0.005% URL/V

Performance specifications

The overall performance including but not limited to 【reference accuracy】 , 【environment temperature effects】 and other comprehensive error

Typical accuracy: ±0.2URL (HART output accuracy: ±0.1URL)

Stability: ±0.1% URL/ year

Loading effects

Zero and span change should not be more than ± 0.05% URL/kΩ

Vibration effects

Vibration resistance According to IEC60068-2-6 , 10g RMS (25-2000Hz)

Impact resistance According to IEC60068-2-27 , 500g/1ms

Ambient temperature effects(Typical)

Within the range - 20-80°C total impact ±0.2%URL/10k

For any changes to the specifications of this catalogue.the latest version shall prevail.



Technical specifications

Output signal

Signal	Type	Output
4-20mA	Linearity	Two wire
4-20mA+HART	Linearity	Two wire
0.5-4.5VDC	Linearity	Three wire
Modbus-RTU/RS485	Linearity	Four wire

Working life

> 10 million max pressure circulation

Insulation resistance

≥20MΩ@, 100VDC

Damping time

Total damping time constant: equal to the sum of damping time of amplifier and sensor capsule

Damping time of amplifier : 0-100S adjustable(with HART protocol)

Startup after power off : ≤3S (HART output time: ≤ 6S)

Normal services after data recovery: ≤4S (HART output time: ≤31S)

Environment condition

Items	Operational condition
Media temperature	-40-85°C
Storage temperature	-40-100°C
Isolated filling fluid temperature	-30-80°C
Working environment humidity	0-95%RH
Protection class	IP65
Dangerous condition	ExiallCT4(GYB16.1964X)*

*Only for 4-20mA output

Technical Specifications

Signal output	4-20mA	4-20mA+HART*	0-5VDC	0.5-4.5VDC(ratiometric output)	RS485
Power supply voltage	10-30VDC	10.5/16.5-55VDC	6-30VDC	5VDC	5VDC/9-30VDC
Electric current	≤20.8mA		≤3.5mA		≤7mA
Load resistance(Ω)	<(U-10)/0.0208	<(U-10.5)/0.0208**	≥5k, recommend 100k		/
Transmission distance	< 1000m		< 5m		< 1200m
Power consumption	≤500mW(20.8mA output@24VDC)		≤42mW(0.5-4.5VDCoutput, @5VDC)		≤168mW(RS485 output@24VDC)

*For this output type, the load resistance value in communication is 250Ω

**The load resistance value 0-2119Ω is in nominal working condition, 250-600Ω is HART communication



Technical specifications

EMC environment(not RS485 signal output)

NO.	Test items	Basic standards	Test conditions	Performance level
1	Radiated interference	GB/T 9254/CISPR22	30MHz-1000MHz	OK
2	Conducted interference (DC power port)	GB/T 9254/CISPR22	0.15MHz-30MHz	OK
3	Electrostatic discharge immunity test (ESD)	GB/T 17626.2/IEC61000-4-2	4kV(Contact),8kV(Air)	B(Note2)
4	Immunity to radio frequency EM-fields	GB/T 17626.3/IEC61000-4-3	10V/m(80MHz-1GHz)	A(Note1)
5	Power frequency magnetic field immunity test	GB/T 17626.8/IEC61000-4-8	30A/m	A(Note1)
6	Electrical fast transient / Burst immunity test	GB/T 17626.4/IEC61000-4-4	2kV(5/50ns,100kHz)	B(Note2)
7	Surge immunity requirements	GB/T 17626.5/IEC61000-4-5	1kV(Line to line) 2kV(Line to ground) (1.2us/50us)	B(Note2)
8	Immunity to conducted disturbances induced by radio frequency fields	GB/T 17626.6/IEC61000-4-6	3V(150kHz-80MHz)	A(Note1)

(Note 1) Performance level A: The performance within the limits of normal technical specifications.

(Note 2) Performance level B: Temporary reduction or loss of functionality or performance, it can restore itself. The actual operating conditions, storage and data will not be changed.

Product selection instruction

Sensor select instruction

Code	Nominal value	Description
L353D	35kPa	Range -35kPa-35kPa, smallest calibratable span 10kPa
L703D	70kPa	Range -70kPa-70kPa, smallest calibratable span 35kPa
L104D	100kPa	Range -100kPa-100kPa, smallest calibratable span 50kPa
L204D	200kPa	Range -200kPa-200kPa, smallest calibratable span 100kPa
L354D	350kPa	Range -350kPa-350kPa, smallest calibratable span 200kPa
L704D	700kPa	Range -500kPa-700kPa, smallest calibratable span 350kPa
L105D	1MPa	Range -0.5MPa-1MPa, smallest calibratable span 500kPa
L205D	2MPa	Range -0.5MPa-2MPa, smallest calibratable span 1MPa
L355D	3.5MPa	Range -0.5MPa-35MPa, smallest calibratable span 1.7MPa

Adjust requirements: lower range value (LRV) and upper range value (URV) can be adjusted within the scope of the upper and lower range limit, smallest calibratable span \leq | URV - LRV | \leq upper range limit

Code	Parts	Description
S	Isolation diaphragm material	SUS316L
S	Isolation fluid filling	Silicon oil
S	Sensor seal	O-ring, FKM, process temperature: -20-200°C)

Seal(S)



Electrical connection select instruction

Code	Description
D1	DIN43650, IP65

DIN43650(D1)

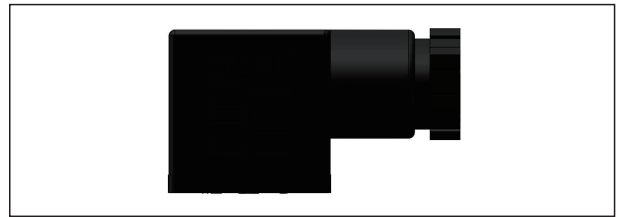

DIN43650(1)

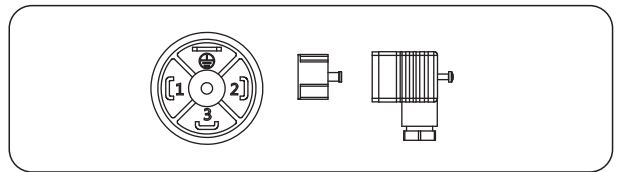

Label	Two wires	Three wires	Four wires	Modbus-RTU/RS485
1	Power+	Power+	Power+	Power+
2	Power-	Power-	Power-	Power-
3	Key-z	Signal+	Signal+	A+
⊕			Signal-	B-

Note: Key-z is modified zero pressure



Product selection instruction

Output signal select instruction

Code	Description
F	4-20mA two wire, power supply: 10-30VDC
H	4-20mA+ HART two wire ,power supply: 16.5-55VDC
R	Modbus-RTU/RS485 5V/9-30VDC
5	1-5V DC three wire, power supply: 16-30VDC
6	0.5-4.5VDC three wire, ratiometric output, power supply: 5VDC
A	4-20mA two wire, Intrinsic safety, power supply: 10-30VDC

Process connection select instruction

Code	Type	Description
4	Material	SS304
6		SS316
M01	Specification	M20*1.5(M), Φ 3 pressure lead hole, GB/T193-2003, ISO261
G01		G1/2(M), Φ 3 pressure lead hole, EN837
G02		G1/4(M), Φ 3 pressure lead hole, EN837
G09		G1/4(F), EN837
R02		1/4NPT(M), ANSI/ASME B1.20.1
R04		1/4NPT(F), ANSI/ASME B1.20.1



Product drawing and dimension

Drawing and dimension with DIN43650(D1) (unit: mm)

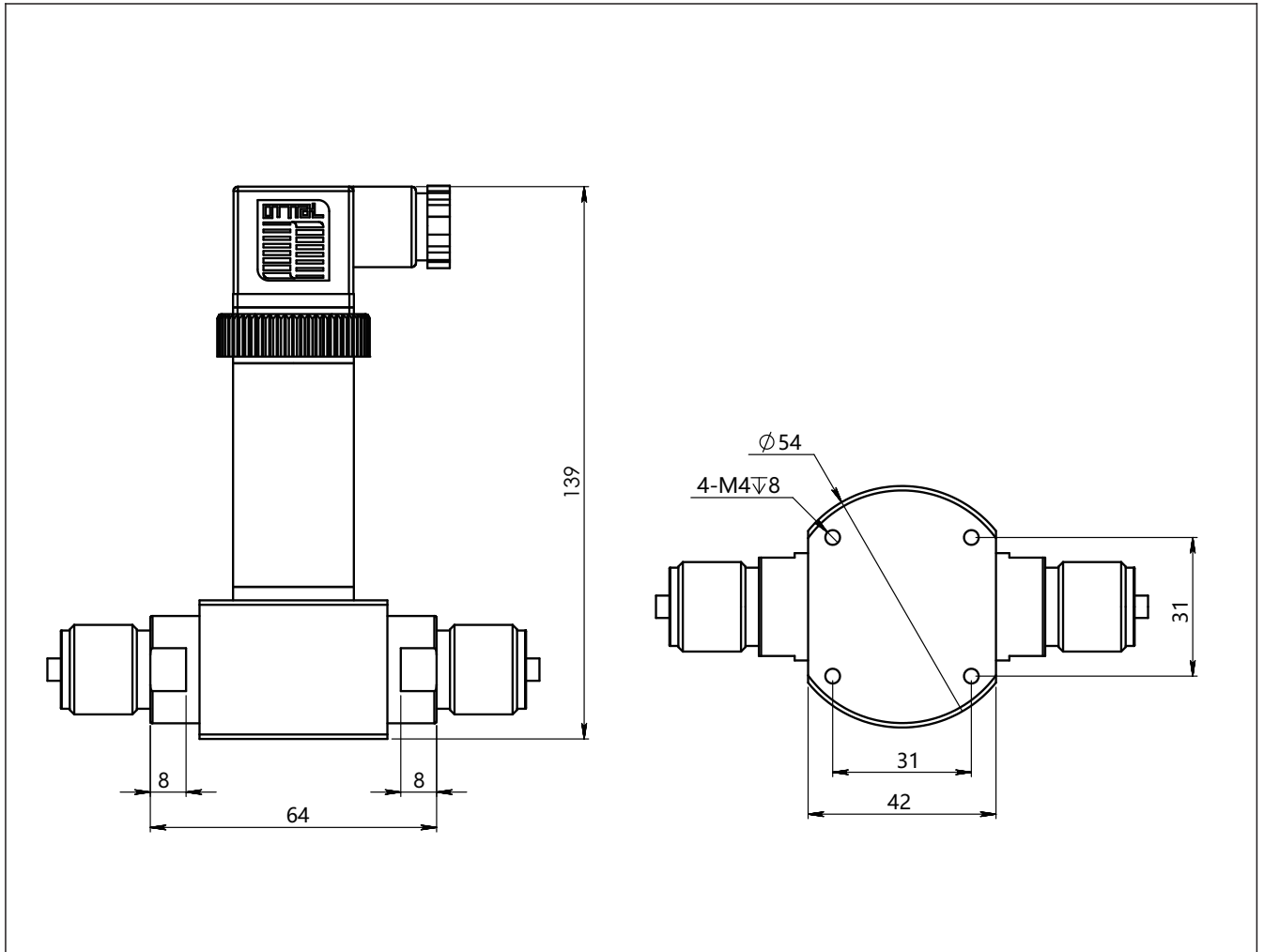

Process connection(M01) (unit: mm)

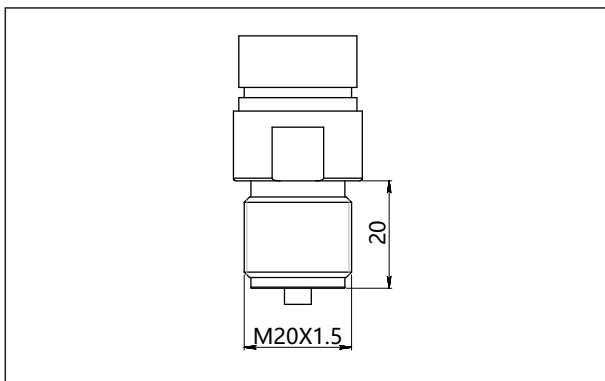

Process connection(G01) (unit: mm)

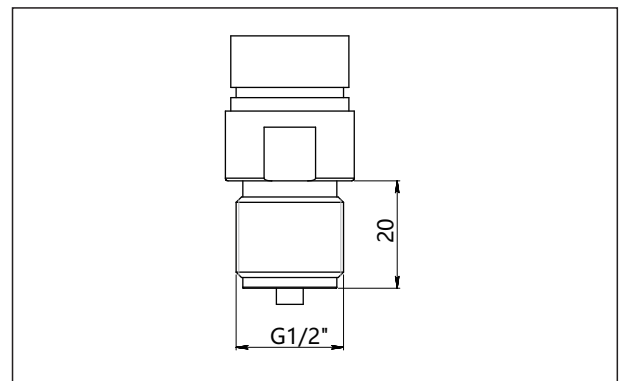

For any changes to the specifications of this catalogue, the latest version shall prevail.



Product drawing and dimension

Process connection(G02) (unit: mm)

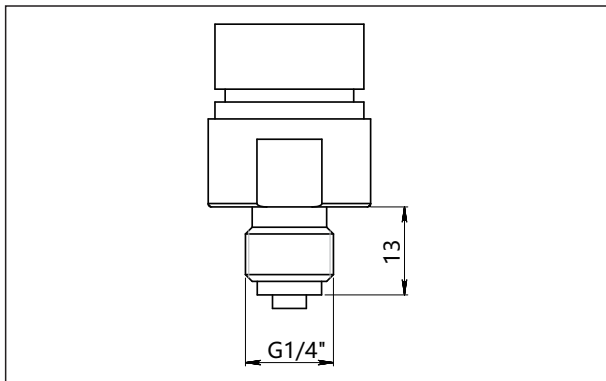

Process connection(G09) (unit: mm)

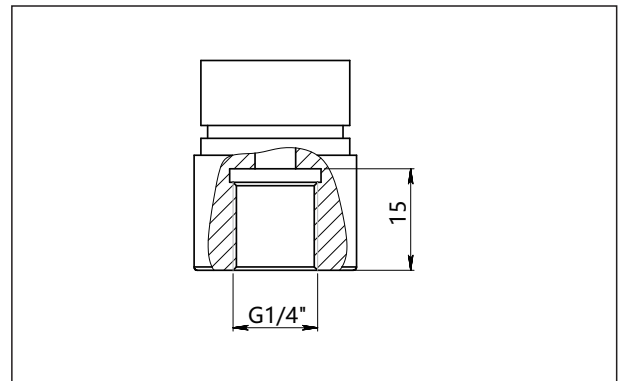

Process connection(R02) (unit: mm)

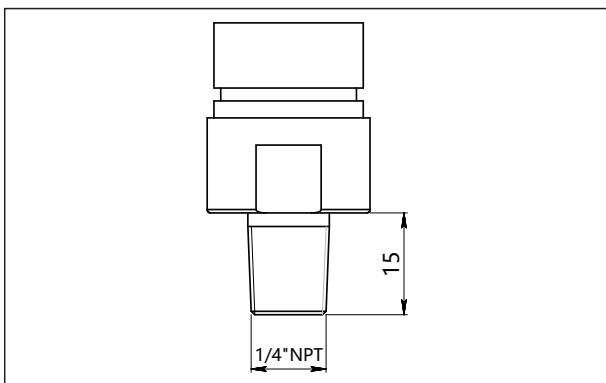

Process connection(R04) (unit: mm)

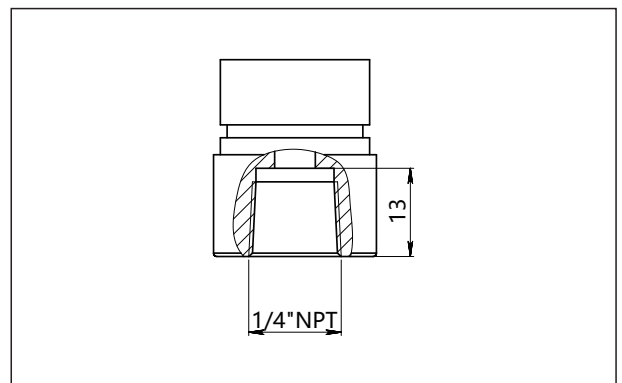

Fixed mounting accessory(G1) (unit: mm)

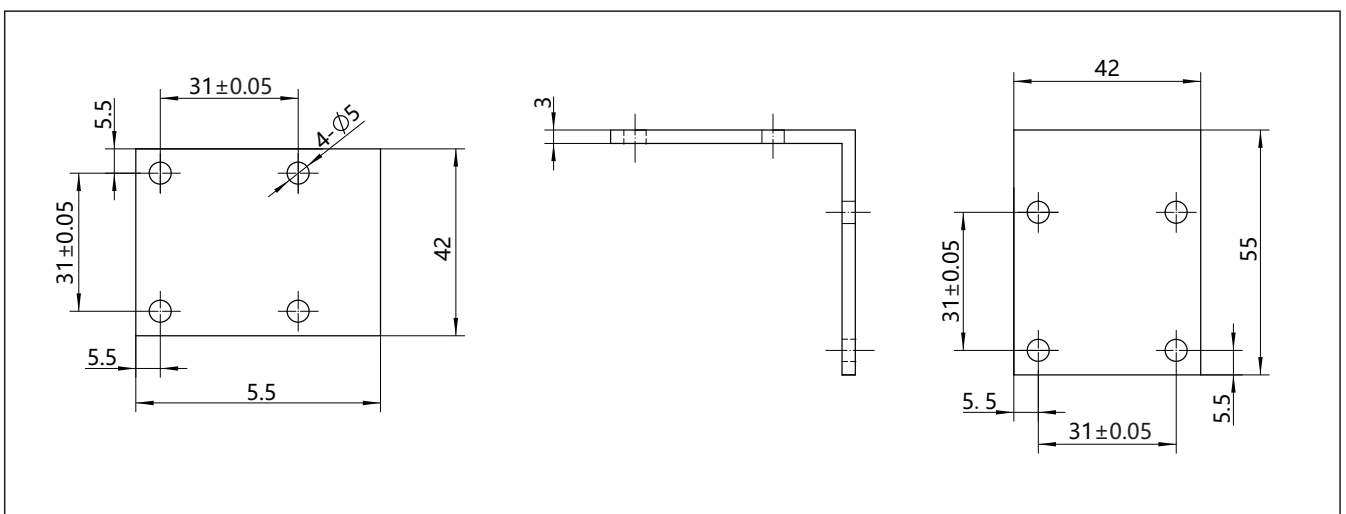

For any changes to the specifications of this catalogue, the latest version shall prevail.



Ordering information chapter

Item	Parameters	Code	Instruction	(*) fast delivery available
	Model	MSSMP131-DLD	Piezoresistive silicon differential pressure sensor	
Sensor	Separator	-	Detailed specifications as following	
	Pressure range code	L353D	Nominal value(URL): 35kPa	
		L703D	Nominal value(URL): 70kPa	
		L104D	Nominal value(URL): 100kPa	*
		L204D	Nominal value(URL): 200kPa	*
		L354D	Nominal value(URL): 350kPa	*
		L704D	Nominal value(URL): 700kPa	*
		L105D	Nominal value(URL): 1MPa	*
		L205D	Nominal value(URL): 2MPa	*
		L355D	Nominal value(URL): 3.5MPa	*
	Isolated diaphragm material	S	SUS316L	*
Isolation fluid filling	S	Silicon oil	*	
Sensor seal	S	O-ring, FKM process temperature: -20-200°C)	*	
Electrical connction	Separator	-	Detailed specifications as following	
	Electrical connction	D1	DIN43650, IP65	*
	Cable entry protector	R0	None	
Output	Separator	-	Detailed specifications as following	
	Output signal	F	4-20mA two wire, power supply: 10-30VDC	*
		H	4-20mA+HART two wire, power supply: 16.5-55VDC	
		R	Modbus-RTU/RS485 four wire, power supply:5vdc/9-30VDC	
		5	0.5-4.5VDC three wire, power supply: 6-15VDC	
		6	0-5VDC three wire, ratiometric output, power supply: 5VDC	
		A	4-20mA two wire, intrinsic safety, power supply: 10-30VDC	
Process connection	Separator	-	Detailed specifications as following	
	Material	4	SUS304	*
		6	SUS316	
	Specification	M01	M20*1.5 (M), Φ3 pressure lead hole, GB/T193-2003, ISO261	*
		G01	G1/2 (M), Φ3 pressure lead hole, EN837	*
		G02	G1/4(M), Φ3 pressure lead hole, EN837	
		G09	G1/4(F), EN837	
		R02	1/4NPT(M), ANSI/ASME B1.20.1	
		R04	1/4NPT(F), ANSI/ASME B1.20.1	

For any changes to the specifications of this catalogue.the latest version shall prevail.

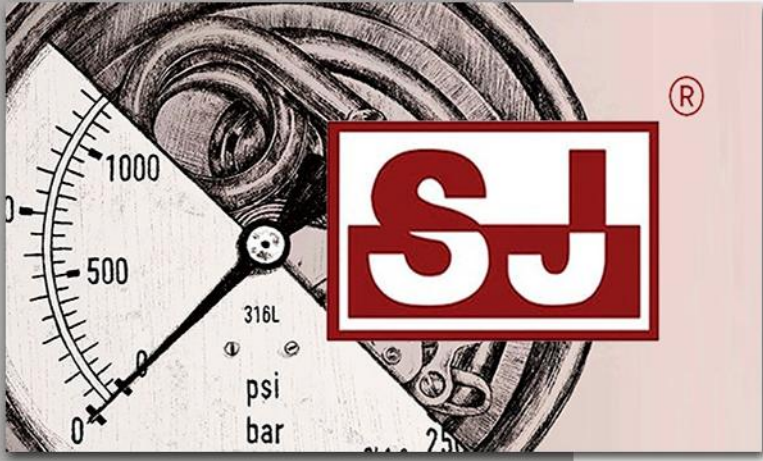

rsIMMA

Elementos For Manufacturing Purposes



MEXICO BRANCH OFFICE

Roberto Diaz No. 401
Ciudad Industrial
Aguascalientes, Ags.
México
20290

4ManPro@4ManPro.com
+52 (449) 171 3420
www.4ManPro.com/SPA/

USA BRANCH OFFICE

708 Main St.
10th Floor
Houston, Tx, USA
77002

4ManPro_USA@4ManPro.com
+1 (832) 871 5022
www.4ManPro.com/ENG/