





# Diaphragm Seal for Homogenizer Machine

Model: DIHO



## PRODUCT SPECIFICATION

### Type

Homogenizer seal, fishtail seal

### Instrument connection

1/4, 3/8, 1/2

PT, G, NPT, M

### Scale ranges

0 ... 100 bar to 0 ... 1000 bar, or all other equivalent pressure ranges

### Material

Body:

304 SS, 316 SS, 316L SS

Diaphragm:

316L SS

### Medium temperature

-35°C ... 260°C,

### Accessories (Options)

Retainer flange (mounting block or sealing block)

## PRODUCT DESCRIPTION



Available with process connections in various designs, fitting with all common measuring points



Designed to prevent aggressive or contaminating medium from entering a conventional pressure gauge



Widely used on homogenizers such as those found in sanitary applications, production of cosmetics and creams, dairies, and the pharmaceutical industry

## DIMENSIONS

Homogenizer seal type

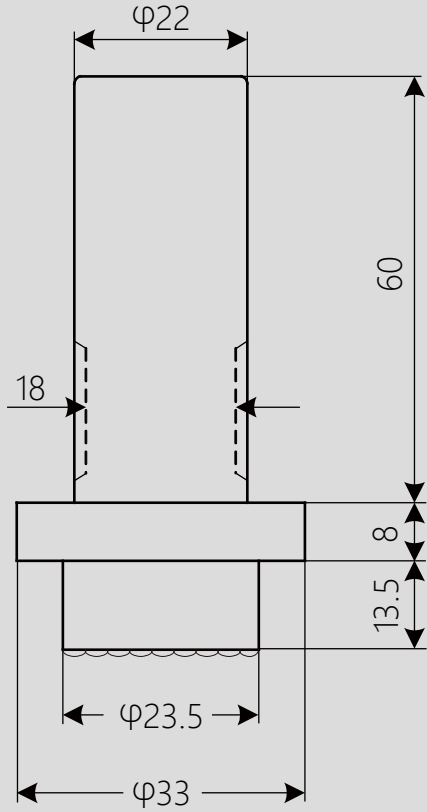

Unit: mm

Fishtail seal type

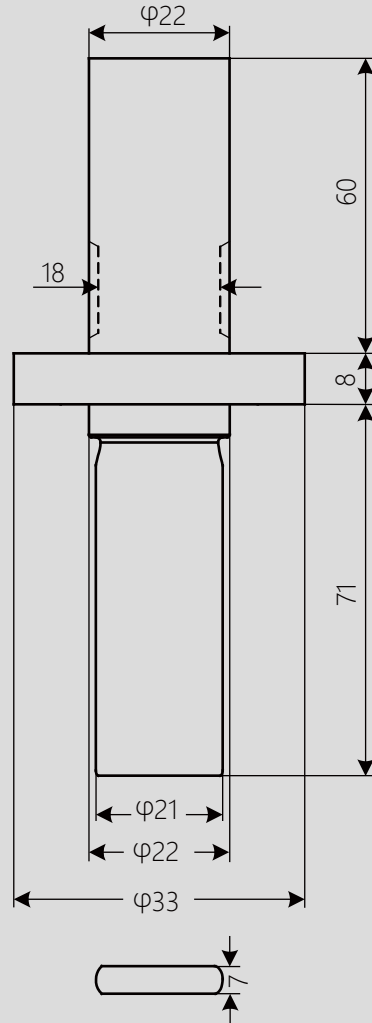

Unit: mm

Retainer flange (mounting block or sealing block)

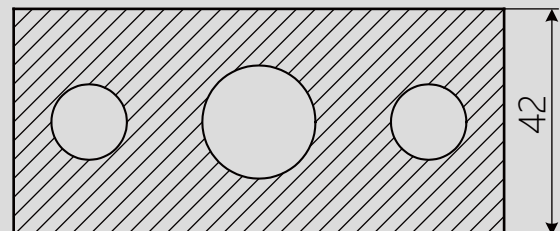
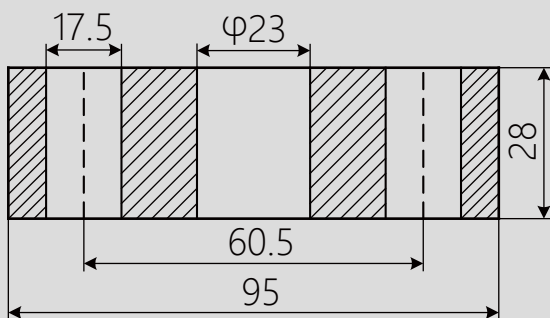

Unit: mm

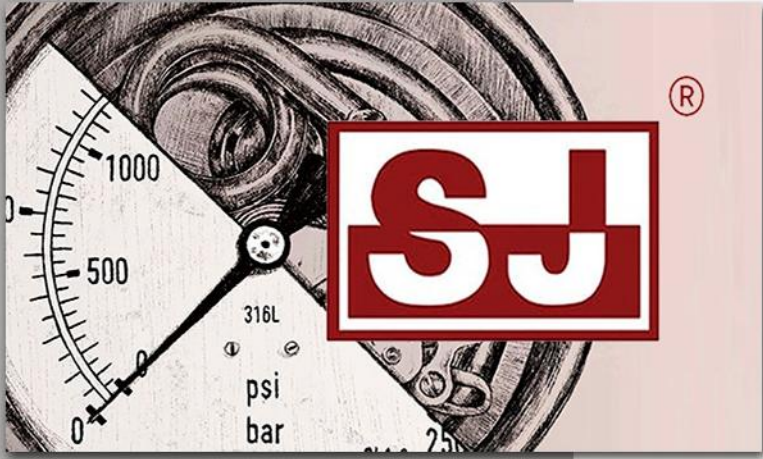

# rsIMAC

*Elementos For Manufacturing Processes*



## MEXICO BRANCH OFFICE

Roberto Diaz No. 401  
Ciudad Industrial  
Aguascalientes, Ags.  
México  
20290

[4ManPro@4ManPro.com](mailto:4ManPro@4ManPro.com)  
+52 (449) 171 3420  
[www.4ManPro.com/SPA/](http://www.4ManPro.com/SPA/)

## USA BRANCH OFFICE

708 Main St.  
10<sup>th</sup> Floor  
Houston, Tx, USA  
77002

[4ManPro\\_USA@4ManPro.com](mailto:4ManPro_USA@4ManPro.com)  
+1 (832) 871 5022  
[www.4ManPro.com/ENG/](http://www.4ManPro.com/ENG/)