



Flanged Connection with Stub Pipe, Upper Metal, Lower Plastic

Model: DIFF-USLP

Product Description

- Enlarged upper seat and diaphragm to enhance accuracy and meet the requirements for pipeline connections
- Material of diaphragm or dual diaphragm can be different from the main body
- Ideal for industries such as electroplating, chemical and petrochemical processing, etc.



Product Specification

Type of process connection

ANSI/ASME B16.5, JIS, DIN 2527

Nominal diameter

1/2", 3/4", 1", 1 1/4", 1 1/2", 2"

Diaphragm diameter^[1]

70 mm, 90 mm, 130 mm, 160 mm

Instrument connection

1/4", 3/8", 1/2"

PT, G, NPT, M

Scale ranges

70 mm

Pressure gauge: 0 ... 4 bar to 0 ... 10 bar

Transmitter: 0 ... 0.4 bar to 0 ... 10 bar

90 mm

Pressure gauge:

-1 ... 0 bar to -1 ... 10 bar

Transmitter:

0 ... 0.01 bar to -1 ... 10 bar

130 mm

Pressure gauge:

0 ... 0.25 bar to -1 ... 10 bar

Transmitter:

0 ... 0.01 bar to -1 ... 10 bar

160 mm

Pressure gauge:

0 ... 0.1 bar to -1 ... 10 bar

Transmitter:

-0.05 ... 0.05 bar to -1 ... 10 bar

or all other equivalent vacuum or

combined pressure and vacuum

ranges

Product Specification

Material

Upper body:

304 SS, 316 SS, 316L SS, Dual Phase

Steel, Hastelloy C276, Tantalum,

Titanium, Monel 400, Nickel 200

Lower body:

PP, PVC, PVDF, PTFE

Diaphragm:

PTFE, Hastelloy C276, Titanium,

Tantalum, Monel 400, Nickel 200,

Silicone, Viton, 316L+PTFE^[2]

Medium temperature

0°C ... 80°C (PVC/PP)、

-40°C ... 140°C (PVDF)、

-200°C...260°C (PTFE)

Others

Welded with instrument,
coating^[3] (PTFE or PFA)

[1] The diaphragm with an outer diameter of 130 mm/160 mm is made of PTFE.

[2] When the diaphragm material is 316L+PTFE, it cannot be used in a vacuum environment.

[3] When the diaphragm seal is coated, it cannot be used for measuring vacuum or granular media.

Dimensions

$\phi 70$ -
Upper Metal, Lower PP/PVC/PVDF

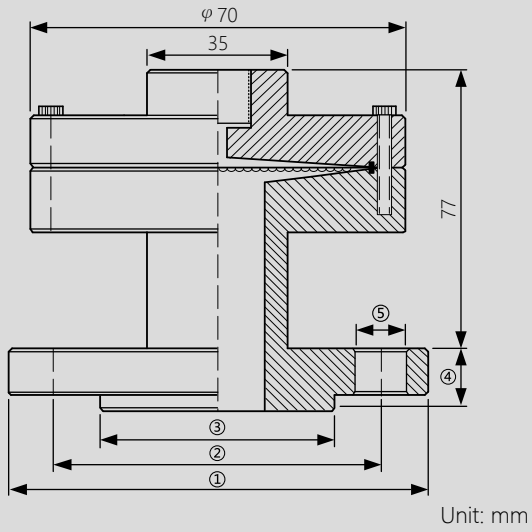

$\phi 90$ -
Upper Metal, Lower PP/PVC/PVDF

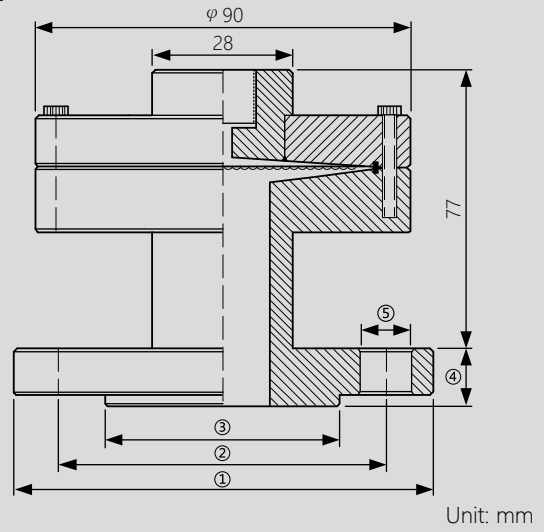

$\phi 130/160$ -
Upper Metal, Lower PP/PVC/PVDF

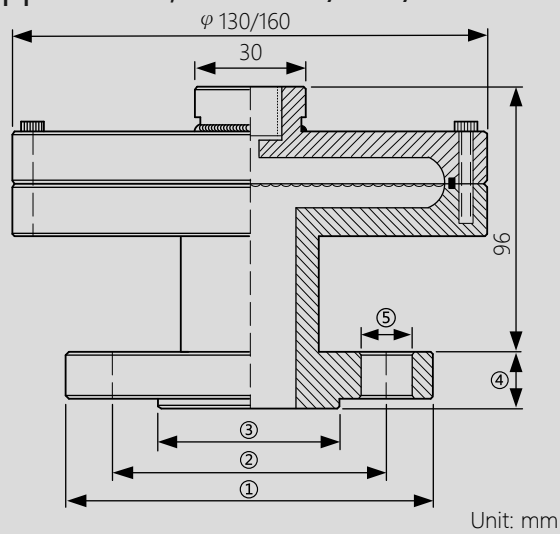

Dimensions

Φ70-Upper Metal, Lower PTFE

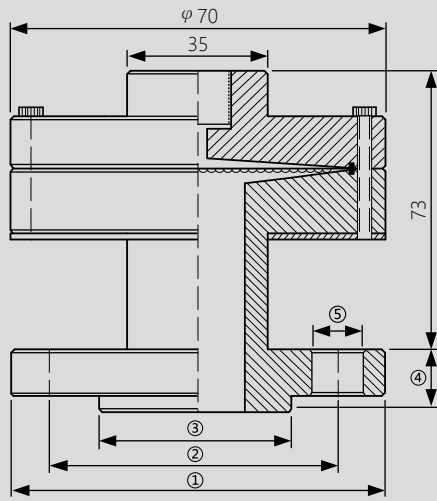

Unit: mm

Φ90-Upper Metal, Lower PTFE

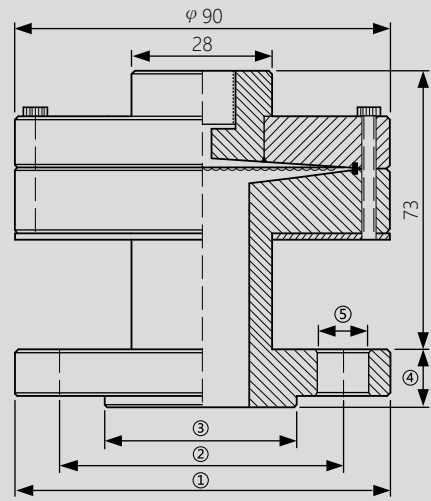

Unit: mm

Φ130/160-Upper Metal, Lower PTFE

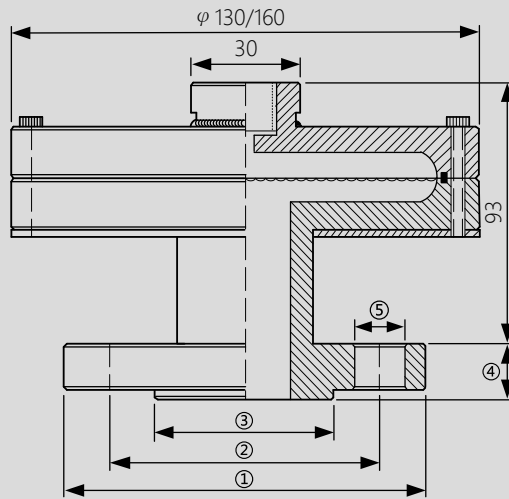

Unit: mm

Dimensions

Dimensions (mm)												
ANSI ASME B16.5	150LB	①	②	③	④	⑤	300LB	①	②	③	④	⑤
	1/2"	89	60.3	35	20	15x4	1/2"	95	66.7	35	20	15x4
	3/4"	98	69.8	43	20	15x4	3/4"	118	82.6	43	20	19x4
	1"	108	79.4	51	20	15x4	1"	124	88.9	51	20	19x4
	1 1/4"	117	88.9	64	20	15x4	1 1/4"	133	98.4	64	20	19x4
	1 1/2"	127	98.4	73	20	15x4	1 1/2"	156	114.3	73	20.7	22x4
	2	152	120.6	92	20	19x4	2	165	127.0	92	22.3	19x8
	600LB	①	②	③	④	⑤	900LB	①	②	③	④	⑤
	1/2"	95	66.7	35	20.7	15x4	1/2"	121	82.6	35	28.7	22x4
	3/4"	118	82.6	43	22.3	19x4	3/4"	130	88.9	43	31.8	22x4
	1"	124	88.9	51	23.9	19x4	1"	149	101.6	51	35	25x4
	1 1/4"	133	98.4	64	27.1	19x4	1 1/4"	159	111.1	64	35	25x4
	1 1/2"	156	114.3	73	28.7	22x4	1 1/2"	178	123.8	73	38.2	28x4
	2	165	127.0	92	31.8	19x8	2	216	165.1	92	44.5	25x8
	1500LB	①	②	③	④	⑤	2500LB	①	②	③	④	⑤
	1/2"	121	82.6	35	28.7	22x4	1/2"	133	88.9	35	36.6	22x4
	3/4"	130	88.9	43	31.8	22x4	3/4"	140	95.3	43	38.2	22x4
	1"	149	101.6	51	35	25x4	1"	159	108.0	51	41.4	25x4
	1 1/4"	159	111.1	64	35	25x4	1 1/4"	184	130.2	64	44.5	28x4
	1 1/2"	178	123.8	73	38.2	28x4	1 1/2"	203	146.1	73	50.9	31x4
	2	216	165.1	92	44.5	25x8	2	235	171.5	92	57.2	28x8

Dimensions

Dimensions (mm)												
JIS	5K	①	②	③	④	⑤	10K	①	②	③	④	⑤
	15A	80	60	48	20	12x4	15A	95	70	52	20	15x4
	20A	85	65	52	20	12x4	20A	100	75	58	20	15x4
	25A	95	75	62	20	12x4	25A	125	90	70	20	19x4
	32A	115	90	72	20	15x4	32A	135	100	80	20	19x4
	40A	120	95	78	20	15x4	40A	140	105	85	20	19x4
	50A	130	105	88	20	15x4	50A	155	120	100	20	19x4
	16K	①	②	③	④	⑤	20K	①	②	③	④	⑤
	15A	95	70	52	20	15x4	15A	95	70	52	20	15x4
	20A	100	75	58	20	15x4	20A	100	75	58	20	15x4
	25A	125	90	70	20	19x4	25A	125	90	70	20	19x4
	32A	135	100	80	20	19x4	32A	135	100	80	20	19x4
	40A	140	105	85	20	19x4	40A	140	105	85	20	19x4
	50A	155	120	100	20	19x8	50A	155	120	100	20	19x8
	40K	①	②	③	④	⑤	63K	①	②	③	④	⑤
	15A	115	80	55	20	19x4	15A	120	85	55	23	19x4
	20A	120	85	60	20	19x4	20A	135	95	60	25	23x4
	25A	130	95	70	22	19x4	25A	140	100	70	27	23x4
	32A	140	105	80	24	19x4	32A	150	110	80	30	23x4
	40A	160	120	90	24	23x4	40A	175	130	90	32	25x4
	50A	165	130	105	26	19x8	50A	185	145	105	34	25x8

JIS reference table								
JIS	15A	20A	25A	32A	40A	50A	80A	100A
	1/2"	3/4"	1"	1 1/4"	1 1/2"	2"	3"	4"

Screw reference table (mm)									
⑤	12	15	19	22/23	25	28	31	34	41
Screw	3/8"	1/2"	5/8"	3/4"	7/8"	1"	1 1/8"	1 1/4"	1 1/2"

Dimensions

Dimensions (mm)												
DIN 2527	PN6	①	②	③	④	⑤	PN10	①	②	③	④	⑤
	DN15	80	55	40	20	11x4	DN15	95	65	45	20	14x4
	DN20	90	65	50	20	11x4	DN20	105	75	58	20	14x4
	DN25	100	75	60	20	11x4	DN25	115	85	68	20	14x4
	DN32	120	90	70	20	14x4	DN32	140	100	78	20	18x4
	DN40	130	100	80	20	14x4	DN40	150	110	88	20	18x4
	DN50	140	110	90	20	14x4	DN50	165	125	102	20	18x4
	PN16	①	②	③	④	⑤	PN25	①	②	③	④	⑤
	DN15	95	65	45	20	14x4	DN15	95	65	45	20	14x4
	DN20	105	75	58	20	14x4	DN20	105	75	58	20	14x4
	DN25	115	85	68	20	14x4	DN25	115	85	68	20	14x4
	DN32	140	100	78	20	18x4	DN32	140	100	78	20	18x4
	DN40	150	110	88	20	18x4	DN40	150	110	88	20	18x4
	DN50	165	125	102	20	18x4	DN50	165	125	102	20	18x4
	PN40	①	②	③	④	⑤	PN64	①	②	③	④	⑤
	DN15	95	65	45	20	14x4	DN15	105	75	45	20	14x4
	DN20	105	75	58	20	14x4	DN20	-	-	-	-	-
	DN25	115	85	68	20	14x4	DN25	140	100	68	24	18x4
	DN32	140	100	78	20	18x4	DN32	155	110	78	24	22x4
	DN40	150	110	88	20	18x4	DN40	170	125	88	26	22x4
DN50	165	125	102	20	18x4	DN50	180	135	102	26	22x4	

DIN reference table								
DIN 2527	DN15	DN20	DN25	DN32	DN40	DN50	DN80	DN100
	1/2"	3/4"	1"	1 1/4"	1 1/2"	2"	3"	4"

Screw reference table (mm)					
⑤	11	14	18	22/23	26
Screw	M10	M12	M16	M20	M27

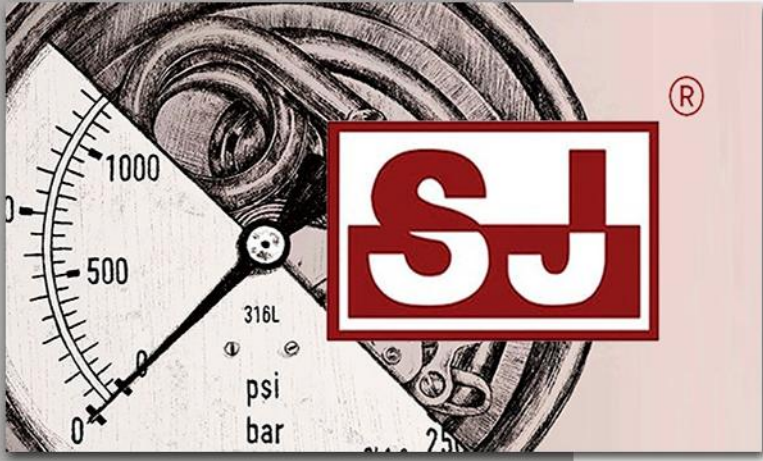

rsIMMA

Elementos For Manufacturing Purposes



MEXICO BRANCH OFFICE

Roberto Diaz No. 401
Ciudad Industrial
Aguascalientes, Ags.
México
20290

4ManPro@4ManPro.com

+52 (449) 171 3420

www.4ManPro.com/SPA/

USA BRANCH OFFICE

708 Main St.
10th Floor
Houston, Tx, USA
77002

4ManPro_USA@4ManPro.com

+1 (832) 871 5022

www.4ManPro.com/ENG/