

# INTERCAMBIADORES DE CALOR

## SERIE ST

 **HYDROME**



**KAORI**  
  
**高力**



# THREADED-TUBE TYPE OIL COOLER

## Dimensions

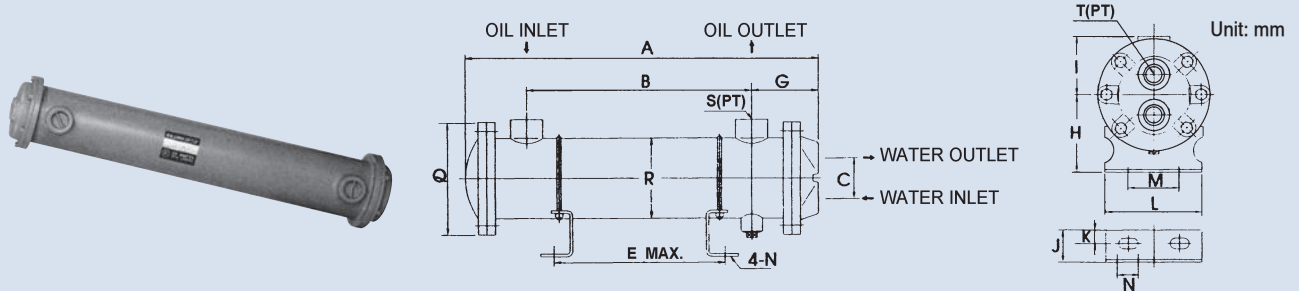

Model	A	B	C	E	G	H	I	J	K	L	M	N	Q	R	S	T	H.D.A m <sup>2</sup>	Flow(lpm)	Weight(kg)
ST-303	300	150	46	100	90	77	63	23	11	115.5	95	7x10	121	89.1	3/4"	3/4"	0.3	50	6.5
304	390	225		175													0.4	60	7.5
305	450	305		235													0.5	70	9.0
307	600	440		380													0.7	110	10.5
309	755	584		525													0.9	130	12.0
311	900	728		675													1.1	150	13.5
ST-408	470	284	70	215	102	103	77	33	12.5	145.5	106.5	10x20	150	114.3	1-1/4"	1"	0.8	130	14
411	610	428		360													1.1	140	16
415	765	572		500													1.5	150	18
418	910	716		650													1.8	160	21
421	1050	860		790													2.1	180	22
ST-518	615	406		76													328	110	118
522	770	558	480		2.2	260	26												
526	820	622	540		2.6	300	28												
530	915	702	620		3	330	30												
534	1075	838	760		3.4	370	33												
542	1255	1055	975		4.2	410	37												
ST-649	1090	836	98	735	134	136	107	34	12.5	205	161	13x16	207	165.2	2"	1-1/4"	4.9	600	47
657	1275	1000		900													5.7	800	53
668	1475	1218		1120													6.8	1000	60
682	1745	1490		1390													8.2	1200	67

## Performance curves

Test condition:

1. The flow rate of water: 20 lpm
2. The inlet temperature of oil: 55 °C
3. The inlet temperature of water: 28 °C
4. The viscosity of oil: ISO-68 cst

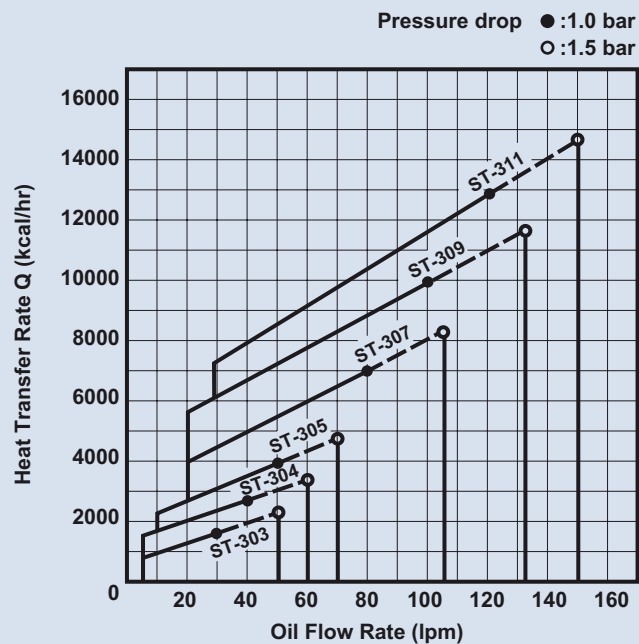

# THREADED-TUBE TYPE OIL COOLER

## Performance curves

### Test condition:

1. The flow rate of water: 40 lpm
2. The inlet temperature of oil: 55 °C
3. The inlet temperature of water: 28 °C
4. The viscosity of oil: ISO-68 cst

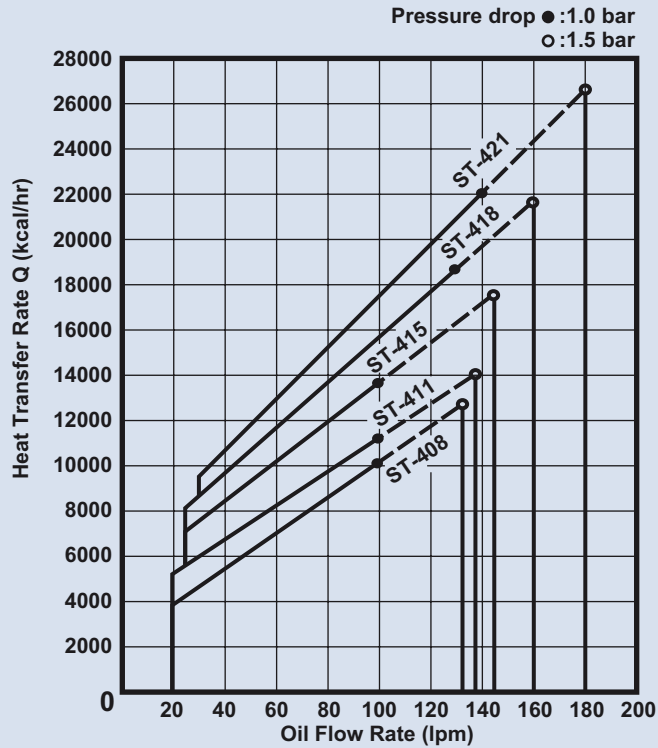

### Test condition:

1. The flow rate of water: 50 lpm
2. The inlet temperature of oil: 55 °C
3. The inlet temperature of water: 28 °C
4. The viscosity of oil: ISO-68 cst

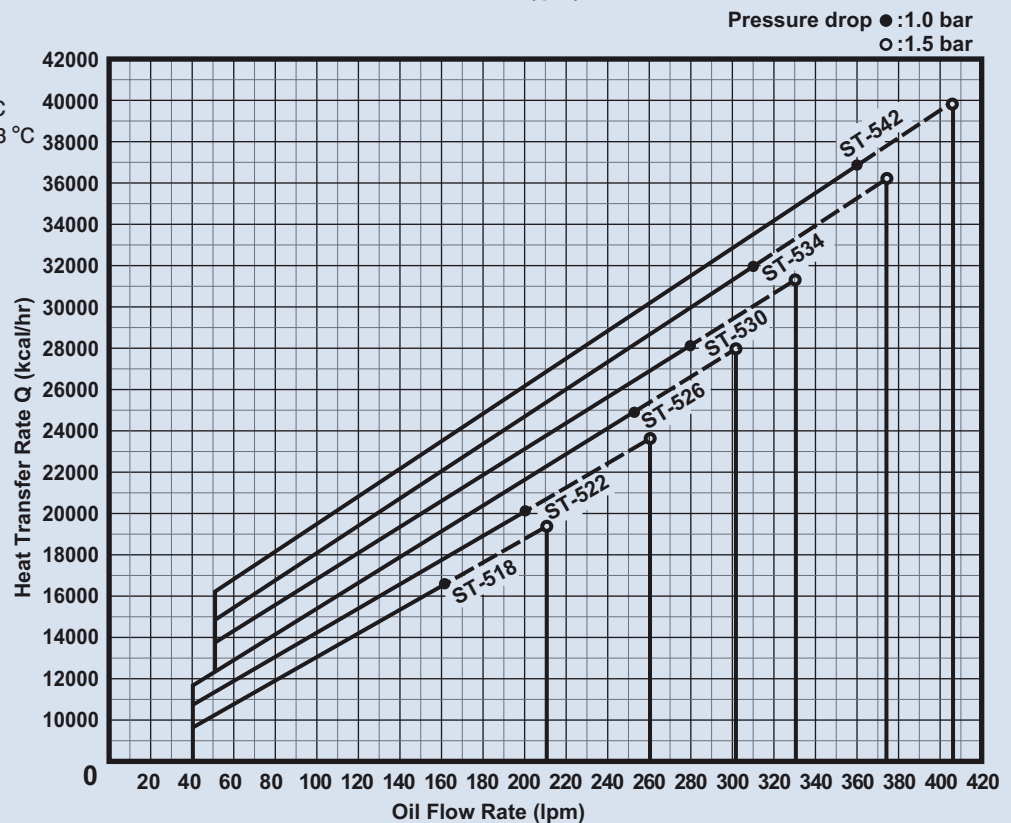

# COOLING PUMP & ANTI-BURST VALVE

## Dimensions

### Cooling pump-for off-line circuit

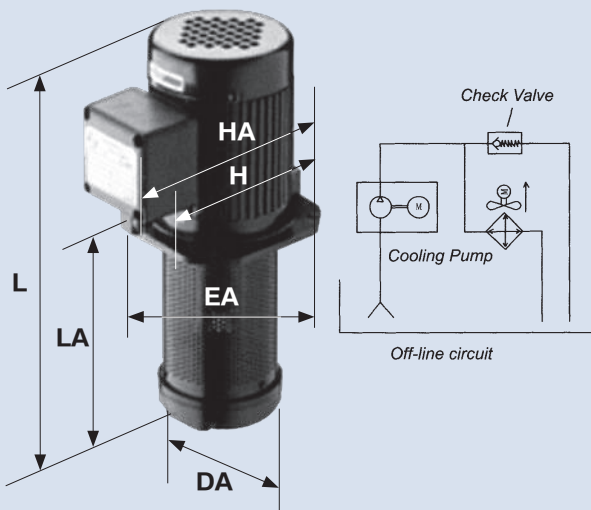

Model	Motor (HP)	Flow Rate (lpm)	L	LA	DA	H	HA	EA	Port (Rc/PT)
TC-6130	1/6	20	275	130	90	124	160	128	1/2"
TC-6180	1/6	20	325	180	90	124	160	128	1/2"
TC-4155	1/4	50	341	155	126	160	191	158	3/4"
TC-4220	1/4	50	406	220	126	160	191	158	3/4"
TC-4350	1/4	50	536	350	126	160	191	158	3/4"
TC-2180	1/2	80	385	180	126	170	196	171	1"
TC-2290	1/2	80	495	290	126	170	196	171	1"
TC-1180	1	120	400	180	151	180	191	185	1"
TC-1240	1	120	460	240	151	180	196	185	1"
TC-1380	1	120	600	380	151	180	196	185	1"

### Anti-burst valve - effective for peak pressure

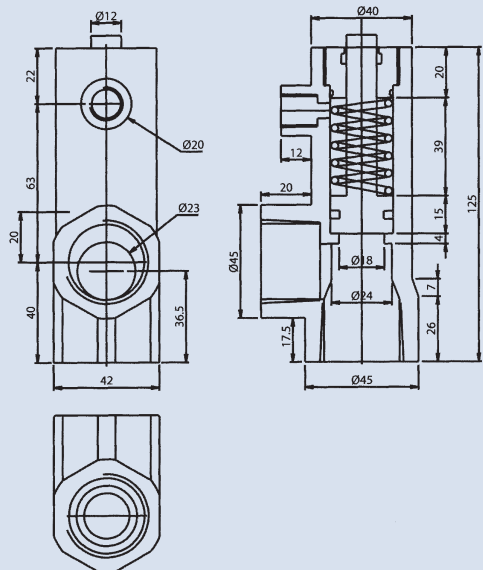
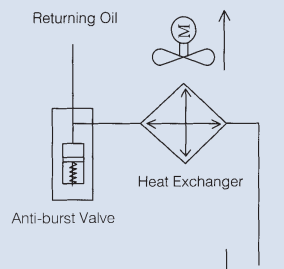
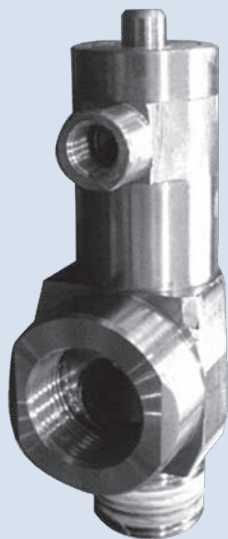

# PLATE-FIN HEAT EXCHANGER

## INSTALLATION & MAINTENANCE

### AH cooler fittings

- Option 1. Off-line circuit is strongly recommended
- Option 2. Use patent product anti-burst Valve Fig.1 / Fig.2
- Option 3. By-pass with check valve (not recommend) Fig.3 / Fig.4

### Special notes for option 3

1. The working pressure for AH series is 20 bar.
2. Be carefully the hammering and pulsations pressure which may cause irreversible damage to the cooler.
3. The spring of check valve may crack after a long period of working.

### Piping caution

1. Outlet pipe's diameter must match with diameter of the port, and cannot be shrank.
2. Using straight joint or flexible pipe to reduce the feedback resistance.
3. More less of curve and curve angles should be better.

**Conclusion: The feedback oil goes as smooth or fast as possible, to get a better heat rejection.**

### Installation

The cooler should be mounted at clean environment where is well ventilated area, keep fan diameter free from both cooling side and hot side.

Avoid locating the cooler at areas where can cause obstruction of air intake or exhaust vent.

Avoid locating the cooler at environment with atmosphere contactining corrosive or flammable dusts, oil mist, conductive power (such as carbon or metal).

If mounted in a closed area, sufficient ventilation must be provided. Heat transfer from the cooling system to ambient air may not increase room temperature, if these conditions are not met, air ducts have to be installed between cooling system and the outside to provide sufficient ventilation.

Check the supply voltage and frequency correspond to the rating plate.

### Maintenance

Before maintenance, please make sure to keep the power off.

Ensure that there are no obstacles to the flow of air, either at the intake or at the outlet from the core, please maintain the cooler termly for a longer life.

### External cleaning of air side

This can be done by either washing the cooler with a mild cleaner (compatible with aluminum), or with compressed air. A power spray washer works well. Care should be taken not to damage the fins. The direction of stream shall be parallel to the fins in order not to damage it. The cooler needs to be dried completely before restarting operation.

### Internal cleaning of cooler side

The cooler should be disconnected, and a suitable cleaning agent used for removing the type of deposit, yet safe on aluminum should be circulated through the cooler until clean. After cleaning procedure, the cleaning medium shall be completely drained and blown out by means of compressed air.

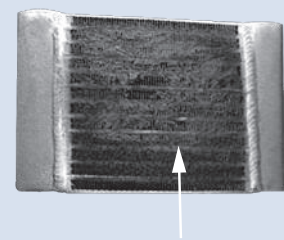
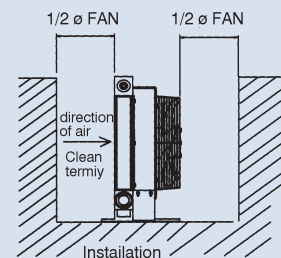
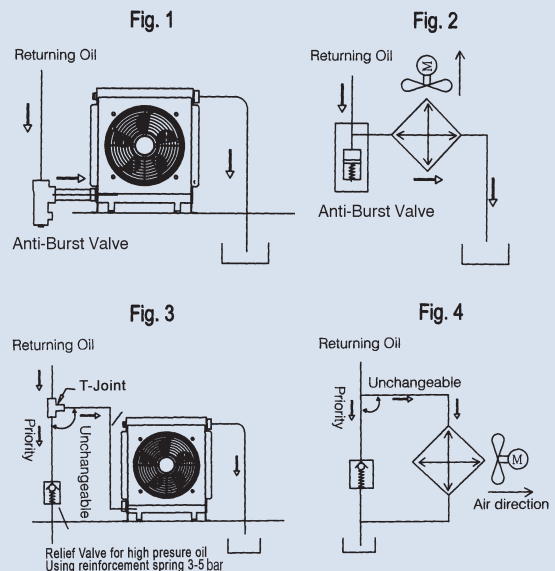

Dust on cooling air inlet side

# PLATE-FIN HEAT EXCHANGER

## CALCULATION OF AIR-OIL HEAT EXCHANGER INSTALLED ON HYDRAULIC SYSTEM

### Introduction:

First of all, the choice of cooling system needs finding out the heat quantity of the hydraulic system, and furthermore we can design the appropriate cooling mode and ability for the requirements of clients.

The quantity of producing heat on hydraulic system can not be estimated by calculation, because of the different of components and elements, using frequency and the design of circuit make this impossible.

1. Choosing the cooler rely on flow rate is only a basic condition, because we choose the input motor horse power by considering the pressure of pump and flow rate in the meantime.
2. The selecting of cooler depended on the quantity of producing heat matches up with the cooling capability on the system.
3. According to the actuality experience, we could count up the appraised value by inputting 70% electricity energy into the heat quantity. (different engineer and elements make this different.)
4. If we are using more delicate components and less heat quantity product, then the 70% heat quantity could be lower to 60% or much lower. Please confirm to your distributor.
5. If there is hydraulic motor in the circuit, then we should calculate the heat quantity up to 100%.

### Data required

#### 1. Simplify

Contrast the input horse power with hydraulic horse power in the performance table, and you could find out the applicable cooler.

#### 2. Calculate

N=installed power in the system (kW)

Q=heat to be dissipated (kcal/h)

To=maximum allowed oil temperature (°C)

Tamb=ambient temperature (°C)

Kr: Means the required specific performance of the heat exchanger

$Kr=Q/\Delta T$ ,  $\Delta T$  is the difference between oil inlet temperature and summer ambient temperature, while Q is the quantity of heat to be dissipated which can be easily calculated considering 60~100% of installed power.

#### Example (hydraulic):

N=20 kW To=50 °C Tamb=35 °C

Q=70% x 20 kW=14 kW=12040 kcal/h (1kW=860 kcal/h)

$\Delta T=50-35=15$  °C

$Kr=12040 \text{ kcal/h} \div 15 \text{ °C}=802 \text{ kcal/h °C}=0.93 \text{ kW/°C}$

The choice of the correct cooler is made by using the diagrams.

You will find in our technical catalogues.

#### Equivalent among main units

1HP=635kcal/h 1kW=860kcal/h 1cSt=1 mm<sup>2</sup>/sec 1BTU=0.25 kcal/h 1bar=100kpa





**MEXICO BRANCH OFFICE**

Roberto Diaz No. 401  
Ciudad Industrial  
Aguascalientes, Ags.  
México  
20290

[4ManPro@4ManPro.com](mailto:4ManPro@4ManPro.com)  
(449) 171 3420  
[www.4ManPro.com/SPA/](http://www.4ManPro.com/SPA/)



**USA BRANCH OFFICE**

**4ManPro®**  
708 Main St.  
10<sup>th</sup> Floor  
Houston, Tx, USA  
77002

[4ManPro-USA@4ManPro.com](mailto:4ManPro-USA@4ManPro.com)  
+1 (832) 871 5022  
[www.4ManPro.com/ENG/](http://www.4ManPro.com/ENG/)

*Elements For  
Manufacturing Processes*

 **HYDROME**