



4ManPro

Elements For Manufacturing Processes



**Serie
MONITOR
HMC**

High Quality Display, Precise Control: The Optimum Combination of Display and Controller

Standard Type

HMC08



Manual Pulse Generator
(MPG)



64K Colors TFT



DMCNET

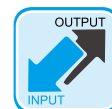

Digital I/O

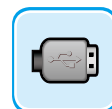

USB Disk



DMCNET

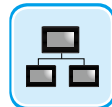

Ethernet



SD Card

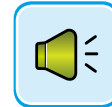

Audio Output

Handheld Type

HMC07 N412

New



Manual Pulse Generator
(MPG)



64K Colors TFT



DMCNET

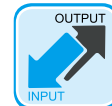

Digital I/O



Nameplate Protection



Emergency Stop



Compact Design

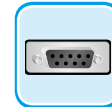

DMCNET



SD Card



Safety Limit Switch



64K Colors TFT



DMCNET

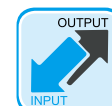

Digital I/O



Nameplate Protection



Emergency Stop



Compact Design

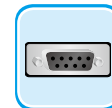

DMCNET



SD Card



DOPSoft for HMI Screen Editing and PLC Programming



Powerful Dual Processors

Equipped with two high-speed CPUs: one for HMI operation, and the other as a Digital Signal Processor (DSP). The DSP serves as a motion processor for sequence control, which guarantees execution efficiency and system performance. The DSP supports up to four major PLC programs simultaneously.

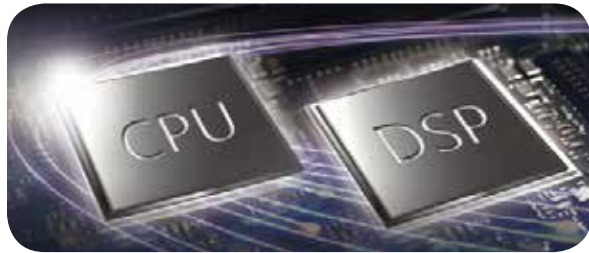

Direct Remote I/O Connection

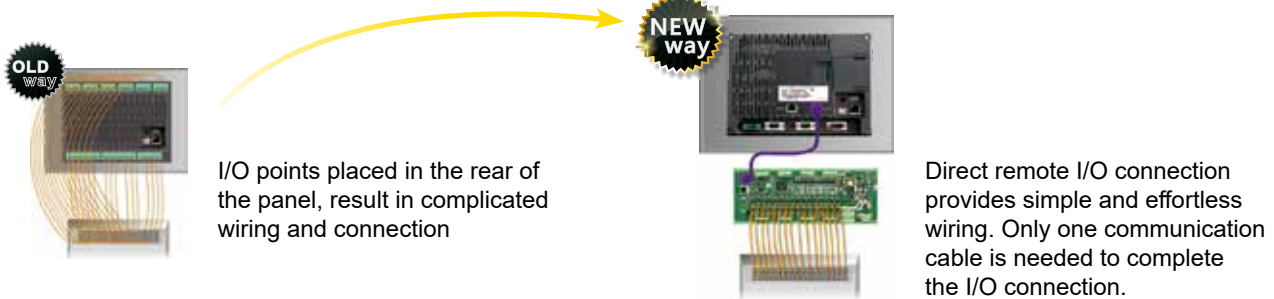

Quick PLC Ladder Monitoring

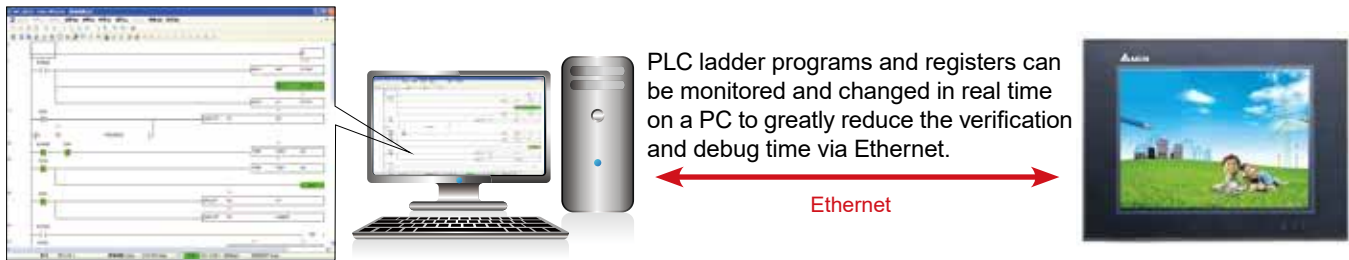

Built-in PLC ladder monitor devices allow users to display programs in real time and confirm machine operations without using a PC.

Full nameplate protection enhances tolerance to various conditions

The new handheld models are equipped with full nameplate protection to prevent oil damage of the PCB and extend product life cycle.

Built-in Motion Commands

Direct servo parameter setup and quick motion command editing, no additional communication commands are required.

Solution Structure

HMC N412 + ASDA-A3 Series

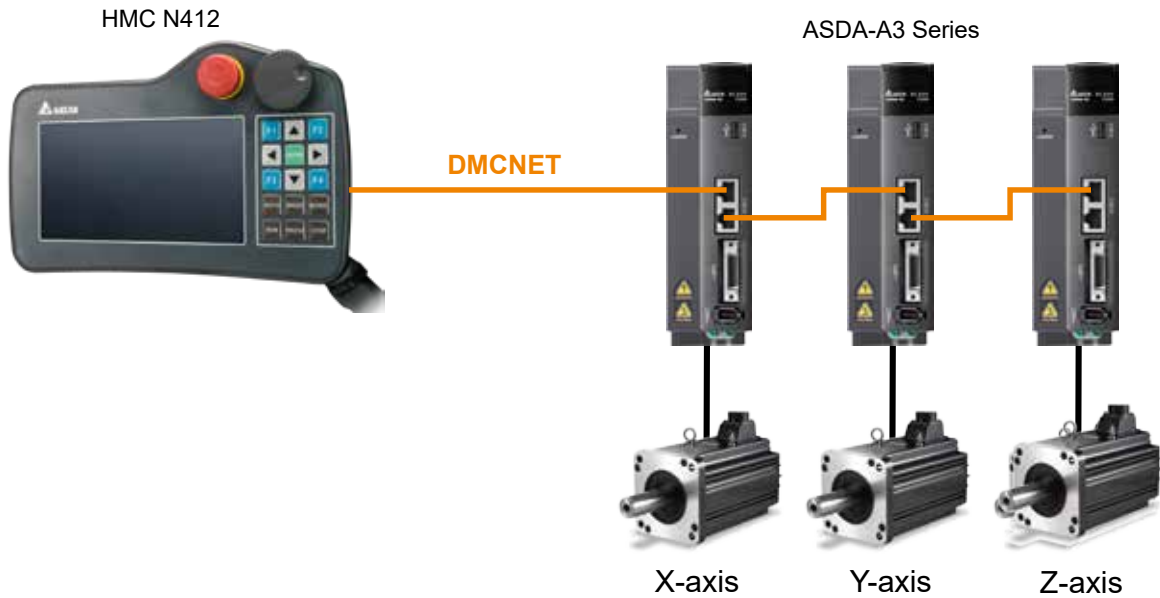

Application

Control of a Pick-an-Place Robot for an Injection Molding Machine

Features

1. The HMC integrates display and remote control functions with built-in PLC
2. High speed motion control bus for Delta Industrial PC-Based Motion Control Solution DMCNET
3. High speed remote I/O modules
4. Built-in ASD-specific motion control device

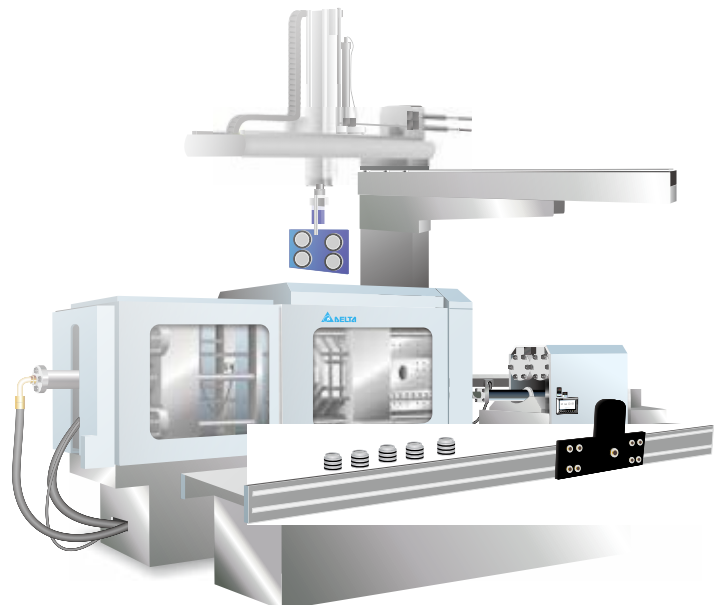

Solution Structure

HMC + AC Servo Drive & Motor ASDA-M
+ AC Servo Drive & Motor ASDA-A2

HMC + AC Servo Drive ASDA-B2
+ E2M Motors

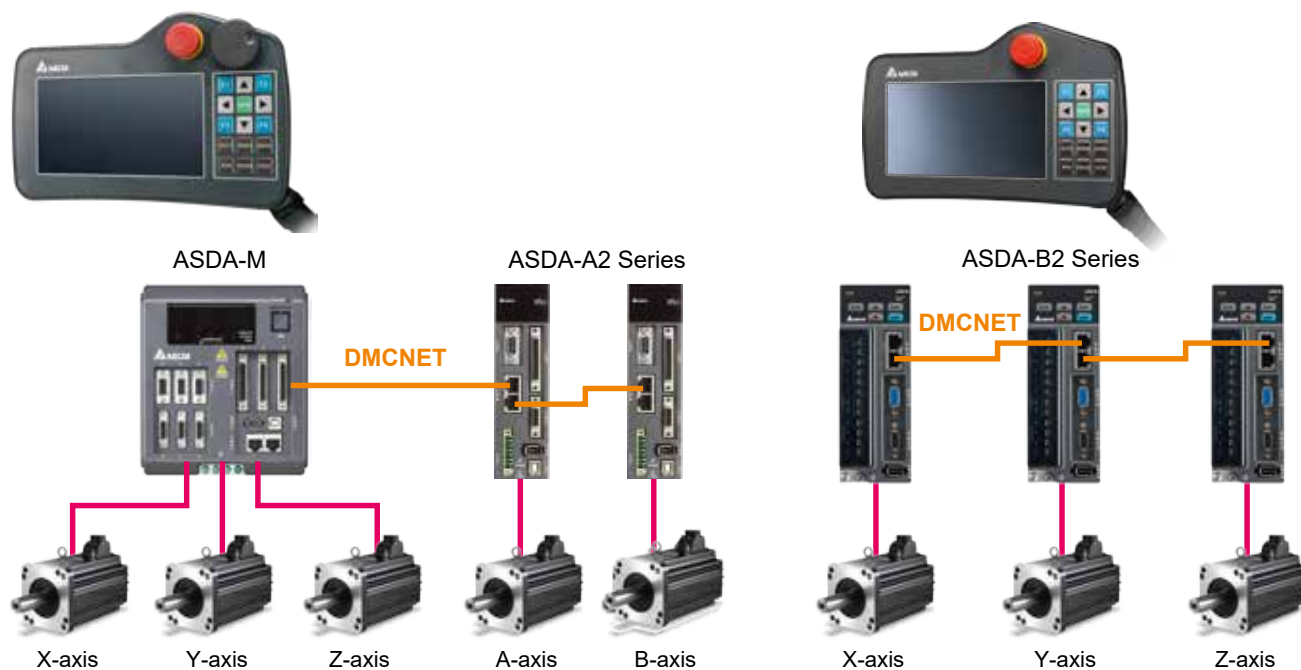

Application

Robotic Loading/Unloading for Machine Tools

Features

Distributed system bus supports various industry applications, large volume of program commands (1000 programs available, 400 edible items in each program) and dual system



New

Application Cases for Quick Implementation

- ▶ System parameter settings: including gear ratio, acceleration / deceleration time and speed

The 'Serve Setting' interface displays a table of system parameters for three axes. The parameters include Gear ratio (Mot. and Don.), S-curve, Acc. time, Dec. time, Homing acc./dec., and Max speed (mm/s and RPM). The Z1 axis is highlighted with a red background.

	Gear ratio (Mot.)	Gear ratio (Don.)	S-curve	Acc. time (ms)	Dec. time (ms)	Homing acc./dec.	Max speed (mm/s)	RPM	Dir.
X1 axis	128	1	125	10	10	600	333.333	2000	C.W.
Y1 axis	128	1	50	10	10	400	333.333	2000	C.W.
Z1 axis	128	1	240	10	10	400	333.333	2000	C.C.W.

The 'Motion Setting' interface displays a table of motion parameters for three axes. The parameters include Homing Offset (mm), Homing Mode, Homing High speed, Homing Low speed, AutoRun speed, Jog speed, and Torque protection (%). The Z1 axis is highlighted with a red background.

	Homing Offset (mm)	Homing Mode	Homing High speed (mm/s)	Homing Low speed (mm/s)	AutoRun speed (mm/s)	Jog speed (mm/s)	Torque protection (%)
X1 axis	0.000	20	50.000	20.000	121.522	100.000	1.0
Y1 axis	0.000	25	50.000	50.000	150.000	100.000	10.0
Z1 axis	0.000	25	50.000	50.000	150.000	100.000	20.0

- ▶ Intuitive teaching interface

The 'TEACH' interface shows a list of instructions for a program. The instructions include Goto T.P., speed, P1, P2, Output[Y1]ON, and Goto T.P., speed, P1, delay. The interface also includes a 'Teach Point' field and a 'T.Point' button.

No.	(Main Sys.) Instructions
1	Goto T.P., speed:5% , P1
2	Goto T.P., speed:5% , P2
3	Output[Y1]ON
4	Goto T.P., speed:5% , P1 , delay:0.0 Sec

- ▶ Positioning setting

The 'Main system Teach Point coordinate' dialog box shows a table of coordinates for eight positions. The columns are Comment, P, #X1 axis, #Y1 axis, and #Z1 axis. The coordinates are: Pos 1 (1, 100.000, 0.000, 0.000), Pos 2 (2, 0.000, 100.000, 0.000), Pos 3 (3, 0.000, 0.000, 0.000), Pos 4 (4, 0.000, 0.000, 0.000), Pos 5 (5, 0.000, 0.000, 0.000), Pos 6 (6, 0.000, 0.000, 0.000), Pos 7 (7, 0.000, 0.000, 0.000), and Pos 8 (8, 0.000, 0.000, 0.000).

Comment	P	#X1 axis	#Y1 axis	#Z1 axis
Pos 1	1	100.000	0.000	0.000
Pos 2	2	0.000	100.000	0.000
Pos 3	3	0.000	0.000	0.000
Pos 4	4	0.000	0.000	0.000
Pos 5	5	0.000	0.000	0.000
Pos 6	6	0.000	0.000	0.000
Pos 7	7	0.000	0.000	0.000
Pos 8	8	0.000	0.000	0.000

- ▶ Operation program management

The 'PROGRAM MANAGE' interface shows a list of programs. The columns are No., Program name, and Modified time. The programs are: 1 DEMO (2015/10/19 10:52:48), 2 N. (2015/10/19 9:28:2), 7 3D (2015/10/19 9:28:2), 8 EDIT-TEST-2 (2015/10/19 9:28:8), 9 EDIT-TEST (2015/10/19 9:29:34), and 10 LD-UL-A (2015/10/19 11:0:13).

No.	Program name	Modified time
1	DEMO	2015/10/19 10:52:48
2	N.	2015/10/19 9:28:2
7	3D	2015/10/19 9:28:2
8	EDIT-TEST-2	2015/10/19 9:28:8
9	EDIT-TEST	2015/10/19 9:29:34
10	LD-UL-A	2015/10/19 11:0:13

- ▶ Operation information

The 'AUTO' interface shows running information for a program. The speed is set to 50%. The running information includes Planned cycles (0), Remainder (0), and Cycle time (0.00 Sec). The interface also includes buttons for Zero Return, Run, Pause, Stop, CycleStop, Magn, and Hand Wheel.

Running Information	
Planned cycles	0
Remainder	0
Cycle time	0.00 Sec

► Abundant operating instructions

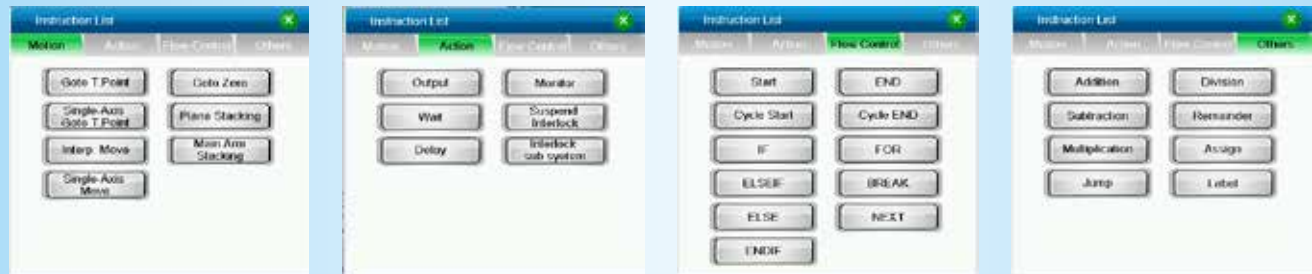

► Jog function



► Security zone setting



► Various stacking instructions

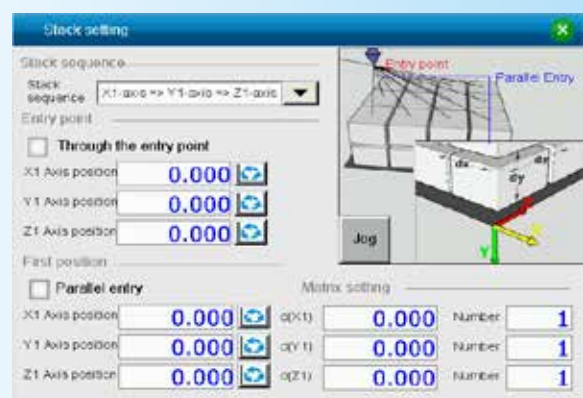
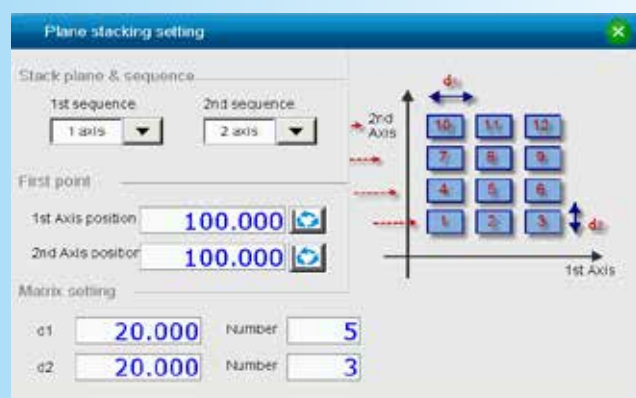

Complete Total Solution

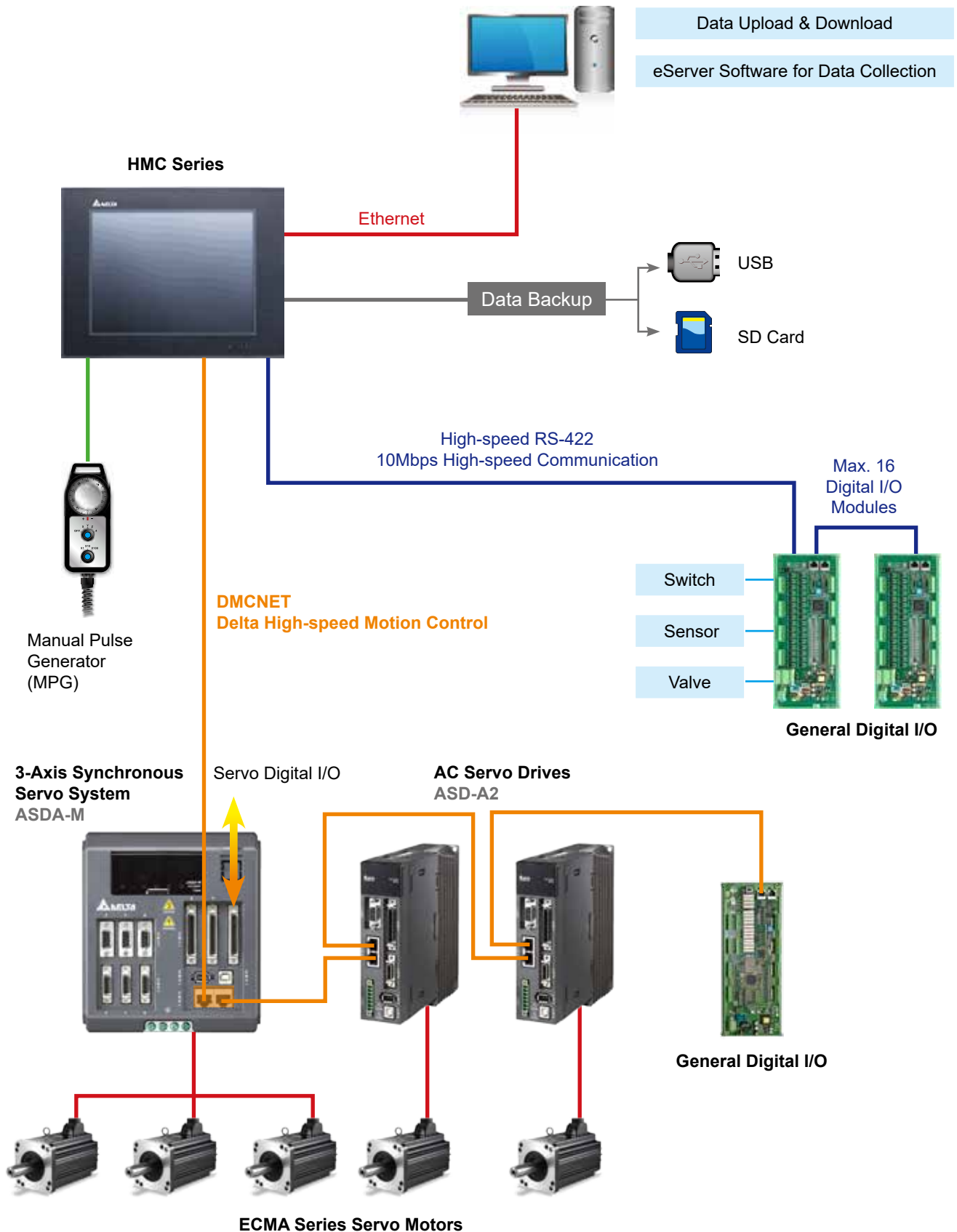



Dimensions Dimensions are in mm (in.)

NEW

Model Name HMC07-N4xx Series

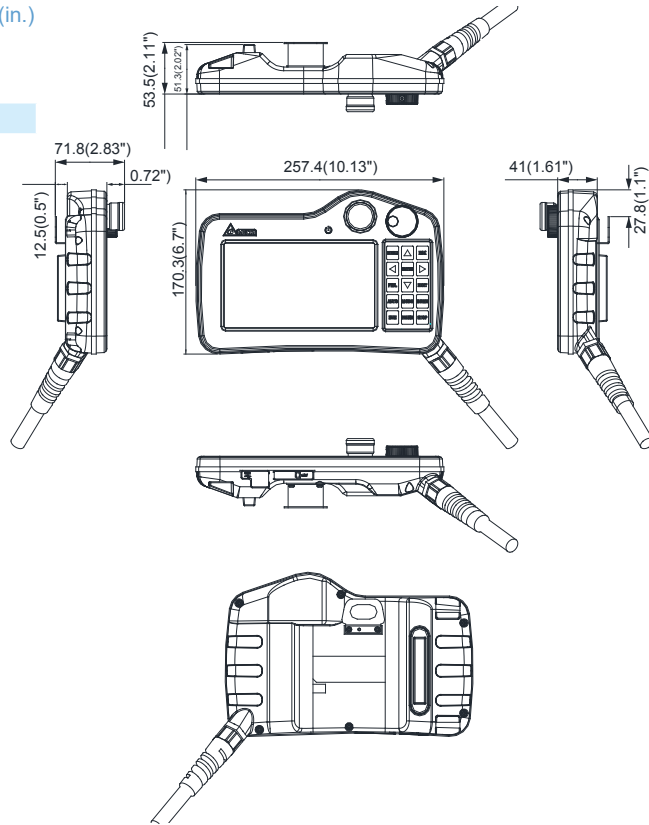

Model Name HMC08-N5xx Series

Model Name Remote I/O Module

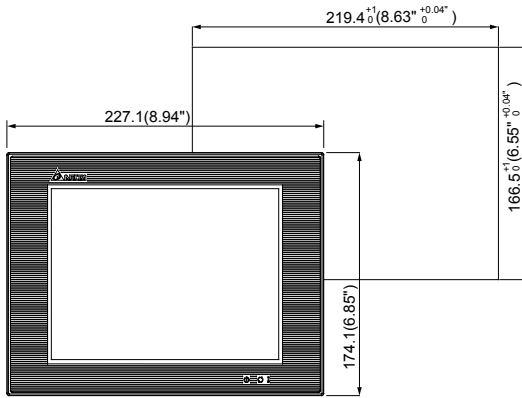

Note:
 T=1.6mm(0.06")
 ~6mm(0.24")
 52.3(2.06")

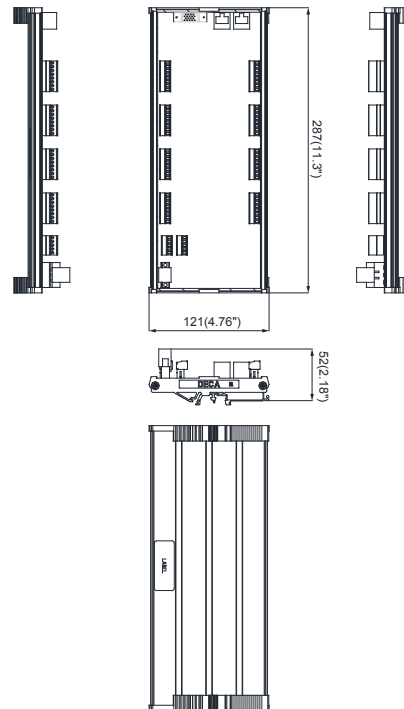

Specifications

Model		HMC07-N412H5CX	HMC07-N412H55X	HMC08-N500S52
LCD Module	Display Type	7" TFT LCD		8" TFT LCD
	Colors	65535		
	Resolution (pixels)	800x480		800x600
	Backlight	LED back light (Half-life >20k hours in 25°C environment) ¹		
	Display Size (mm)	154.08 x 85.92		162 x 121.5
Axes of Control		Max. 12 axes		
Operating System		Delta Real Time OS		
CPU	HMI	32-bit RISC Micro-controller		
	Controller	32-bit DSP		
Flash ROM (Bytes)		Flash ROM 128 MB (OS System: 30 MB / Backup: 16 MB / User Application: 82 MB)		
Backup Memory (Bytes)		16 MB ROM, 128 KB SRAM		
Buzzer		Multi-Tone Frequency (2K ~ 4 KHz) / 85 dB		
Communication Networks	Ethernet	N/A		1
	Social COM Port	RS-485 (Built-in power isolation ²)		RS-232/RS-422/RS-485 ²
	Motion Control BUS	DMCNET		
	USB	1 USB Slave Ver 2.0		1 USB Host Ver 1.1 / 1 USB Slave Ver 2.0
SD		SD/SDHC		
Emergency Stop Switch		Push-lock switch Output: 2 contacts B-contact (normally closed) x 2 Rated voltage: DC 30V Max. rated current: 500 mA Min. load allowed: 5VDC / 1 mA		N/A
3-Position Operation Switch		Only for internal register, no output signal	N/A	N/A
Manual Pulse Generator (MPG)		Only for internal register, no output signal	N/A	N/A
Function Key		15		N/A
Cable Length		The X in HMC model name indicates cable length ³		N/A
Perpetual Calendar		Built-in		
Cooling Method		Natural cooling		
Safety Certification		CE		CE/UL
Protection Rating		IP54		IP65
Voltage		DC+24V _{DC} (±15%) ⁴ (Supplied by SELV circuits isolated from MAINS by double insulation)		
Voltage Endurance		Between DC24 terminal and FG terminal: AC500V, 1 min		
Power Consumption		6W ⁵		11 W
Backup Battery		3V lithium CR2450 × 1		3V lithium CR2032 × 1
Backup Batter Life		5 years or more at 25°C, may vary due to temperature and usage condition		
Operation Temperature		0°C ~ 40°C		0°C ~ 50°C
Storage Temperature		-10°C ~ 60°C		
Operation Environment		10% ~ 90% RH 【0 ~ 40°C】, 10% ~ 55% RH 【41 ~ 50°C】, Pollution Degree 2		
Vibration		IEC61131-2 compliant 5Hz ~ 8.3Hz 3.5mm, 8.3Hz ~ 150Hz 1G		
Shock		IEC60068-2-27 compliant 11 ms, 15G Peak, X, Y, Z direction for 6 times		
Dimensions (W) x (H) x (D) mm		257.4 x 170.3 x 71.8 (Emergency stop button and hook included)		219.4 x 174.1 x 52.3
Weight		750g (Wire excluded)		about 1314g

Note:

- 1) The half-life of the backlight is defined as the original luminance being reduced by 50% when the maximum driving current is supplied to the HMI
- 2) The isolated power circuit can withstand a 1500 V for 1 minute.
- 3) X = 5 : 5m, X = A : 10m, X = F : 15m, X = K : 20m
- 4) Isolated power supply recommended
- 5) The value of the power consumption indicates the electrical power consumed by HMI with no peripheral devices connected. To ensure normal operation, it is recommended using a power supply with a capacity 1.5 ~ 2 times the value of the power consumption

Model List

Model Name	Descriptions
HMC07-N412H555	HMC 7" NORMAL WSVGA HANDLE DMC WB 5M
HMC07-N412H55A	HMC 7" NORMAL WSVGA HANDLE DMC WB 10M
HMC07-N412H55F	HMC 7" NORMAL WSVGA HANDLE DMC WB 15M
HMC07-N412H55K	HMC 7" NORMAL WSVGA HANDLE DMC WB 20M
HMC07-N412H5C5	HMC 7" NORMAL WSVGA HANDLE DMC WB 5M
HMC07-N412H5CA	HMC 7" NORMAL WSVGA HANDLE DMC WB 10M
HMC07-N412H5CF	HMC 7" NORMAL WSVGA HANDLE DMC WB 15M
HMC07-N412H5CK	HMC 7" NORMAL WSVGA HANDLE DMC WB 20M
HMC07-R412H555	HMC 7" NORMAL WSVGA HANDLE DMC WB 5M
HMC07-R412H55A	HMC 7" NORMAL WSVGA HANDLE DMC WB 10M
HMC07-R412H5C5	HMC 7" NORMAL WSVGA HANDLE DMC WB 15M
HMC07-R412H5CA	HMC 7" NORMAL WSVGA HANDLE DMC WB 20M
HMC08-N500S52	HMC 8" NORMAL SVGA STD DMC RS422 WB
HMC08-N511M52	HMC 8" NORMAL SVGA MODULE DMC WB

Electrical Specifications of Remote I/O Modules

Items / Model Name	Power Supply	Input Unit		Output Unit	
		Points	Type	Points	Type
HM-RIO3232T12	24 V _{DC}	32	NPN (Sink)	32	Transistor
Input Point Electrical Specifications			Output Point Electrical Specifications		
Input Impedance		4.7 KΩ		Max. Switching Frequency	
Max. Switching Frequency		100 kHz		500 kHz	
Active Level	Off → On	> 16.5 V _{DC}		Response Time (Relay)	On → Off
	On → Off	< 5 V _{DC}			On → Off
Response Time	Off → On	< 3 μs		-	
	On → Off	< 40 μs		-	

Items / Model Name	Power Supply	Input Unit		Output Unit	
		Points	Type	Points	Type
HMC-RIO3232RT5	24 V _{DC}	32	NPN (Sink) / PNP (Source)	16 Relay / 16 TR	Relay / Transistor
Input Point Electrical Specifications			Output Point Electrical Specifications		
Input Impedance		4.7 KΩ		Max. Switching Frequency	
Max. Switching Frequency		10 kHz		1 Hz (Relay) / 8 kHz (TR)	
Active Level	Off → On	> 16.5 V _{DC}		Response Time (Relay)	Off → On
	On → Off	< 5 V _{DC}			On → Off
-		-		Response Time (TR)	Off → On
					On → Off

Model Introduction

HMC Series

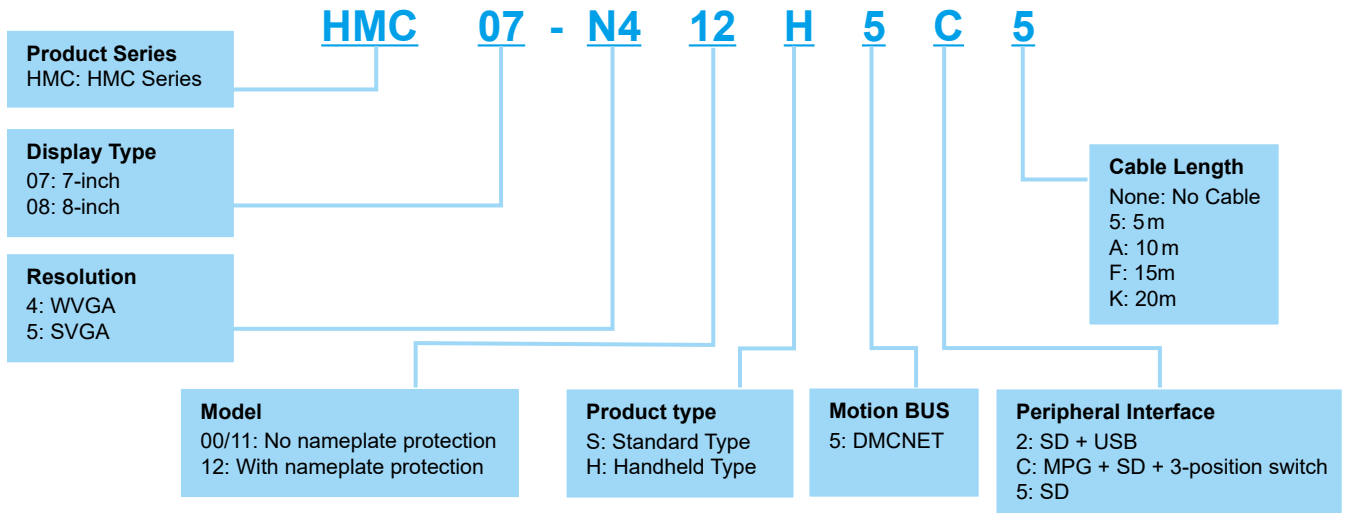

Servo Motors ECMA Series

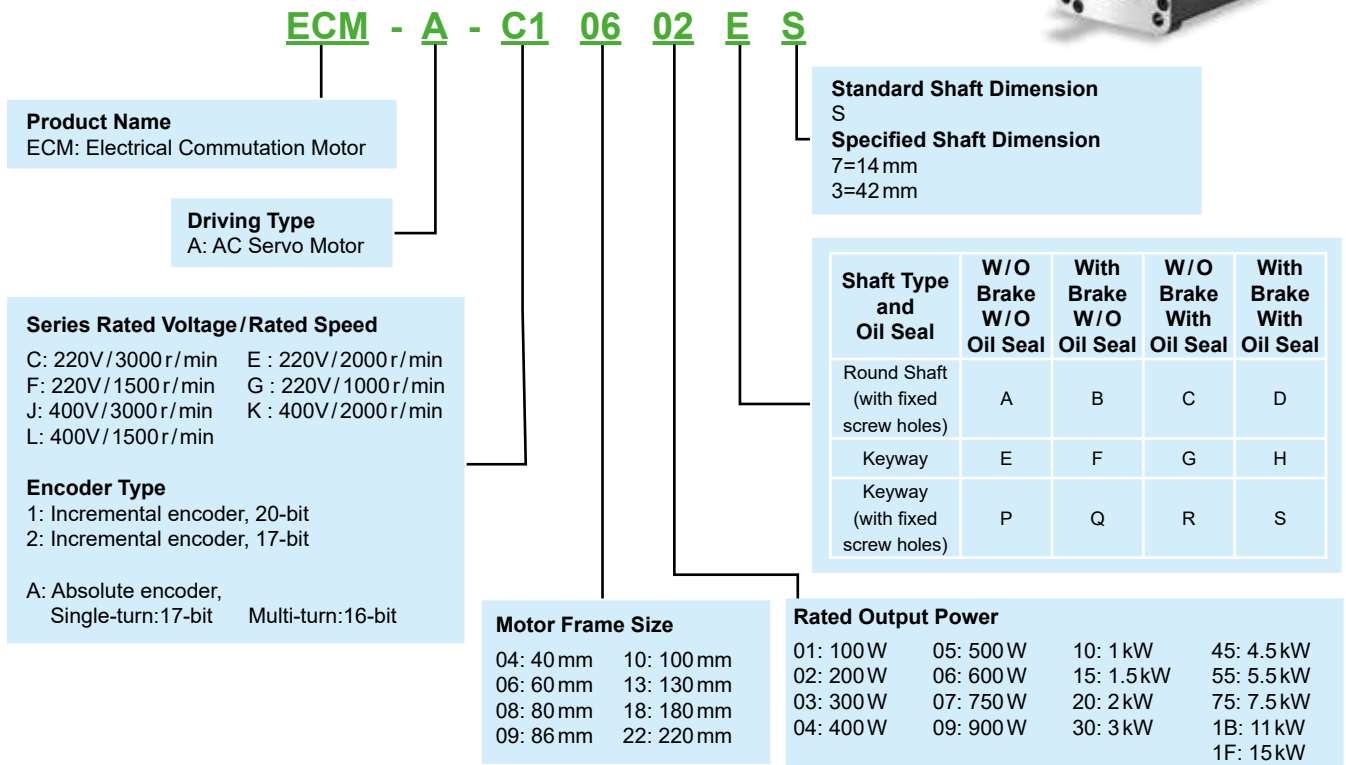

Servo Drives ASDA-M Series



ASD - M - 07 21 - F

Product Name: AC Servo Drive

Series: M

F: DMCNET

Input Voltage and Phase
 21: 220V 1-phase
 23: 220V 3-phase

Rated Output Power
 07: 750 W
 15: 1.5 kW

Servo Drives ASDA-A2 Series



ASD - A2 - 04 21 - F

Product Name: AC Servo Drive

Series: A2

F: DMCNET

Input Voltage and Phase
 21: 220V 1-phase/3-phase
 23: 220V 3-phase
 43: 400V 3-phase

Rated Output Power

01: 100 W	20: 2.0 kW
02: 200 W	30: 3.0 kW
04: 400 W	45: 4.5 kW
07: 750 W	55: 5.5 kW
10: 1.0 kW	75: 7.5 kW
15: 1.5 kW	1B: 11 kW
	1F: 15 kW

Optional Accessories

Model Name	Descriptions
HMC-CA3205C0	Handheld types HMC07-N5xx Series connection cable (5 m, 32-pin)
HMC-CA3210C0	Handheld types HMC07-N5xx Series connection cable (10 m, 32-pin)
HMC-CA1205C0	Handheld types HMC07-N5xx Series connection cable (5 m, 12-pin)
HMC-CA1210C0	Handheld types HMC07-N5xx Series connection cable (10 m, 32-pin)
NC-CAB-DMC003	DMCNET/Remote I/O connection cable (0.3 m)
NC-CAB-DMC015	DMCNET/Remote I/O connection cable (1.5 m)
NC-CAB-DMC050	DMCNET/Remote I/O connection cable (5 m)
NC-CAB-DMC100	DMCNET/Remote I/O connection cable (10 m)

Global Operations

ASIA (Taiwan)



Taoyuan Technology Center (Green Building)



Taoyuan Plant 1



Tainan Plant (Diamond-rated Green Building)

ASIA (China)



Wujiang Plant 3



Delta Electronics



ASIA (Japan)



Tokyo Office

ASIA (India)



Rudrapur Plant
(Green Building)

EUROPE



Amsterdam, Netherlands

AMERICA



Research Triangle Park

▲ Factories 8 ■ Branch Offices 117 ● R&D Centers 13 ■ Distributors 915

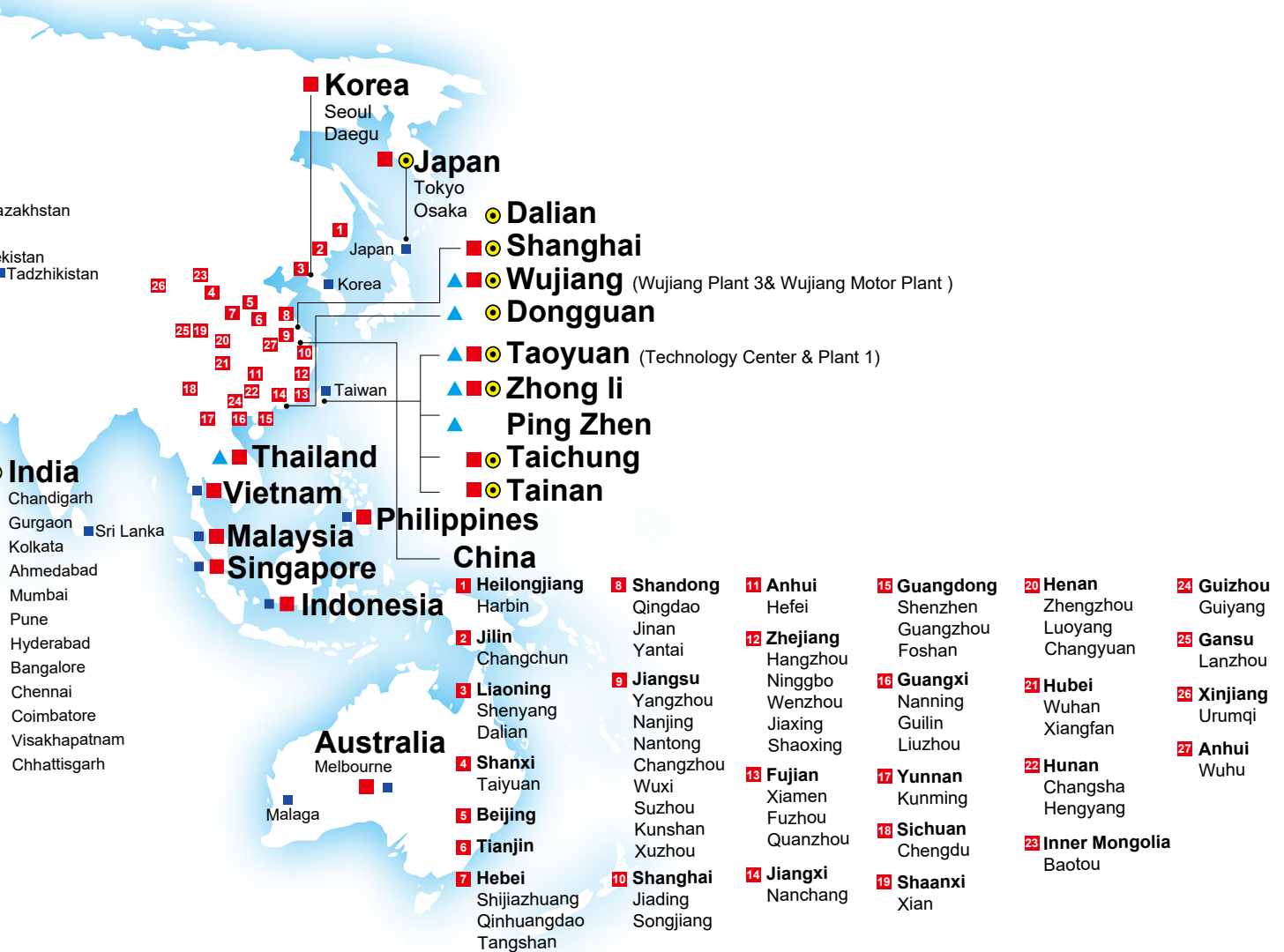

MEXICO BRANCH OFFICE

Roberto Diaz No. 401
Ciudad Industrial
Aguascalientes, Ags.
México
20290



USA BRANCH OFFICE

4ManPro®
708 Main St.
10th Floor
Houston, Tx, USA
77002

4ManPro@4ManPro.com
(449) 171 3420
www.4ManPro.com/SPA/

4ManPro-USA@4ManPro.com
+1 (832) 871 5022
www.4ManPro.com/ENG/

*Elements For
Manufacturing Processes*



DELTA