



MOTOREDUCTORES COMPACTOS



LIMING REDUCERS

小型齒輪減速機系列 SMALL GEAR REDUCER



小型戟齒輪減速機系列 SMALL HYPOID GEAR REDUCER



小型同心軸戟齒輪減速機系列 SMALL HYPOID GEAR REDUCER(Concentric Shaft)









註：另有實心軸系列 (SK-D)

NOTE: There are also solid shaft series (SK-D)

小型蝸輪減速機系列 SMALL WORM REDUCER



目次

A		SH	小型齒輪減速機 Small Gear Reducer	02 - 10
B			小型蝸輪減速機 Small Worm Reducer	11 - 15
C		SL	小型戟齒減速機 (偏心系列) Small Hypoid Reducer (Eccentric Type)	16 - 58
D		SK	小型戟齒減速機 (同心系列) Small Hypoid Reducer (Concentric Type)	59 - 86
E		SGW	小型齒蝸減速機 (同心系列) Small Gear Worm Reducer (Concentric Type)	87 - 113
F		S□A	倂服用小型齒輪 / 戟齒減速機 Small Gear Reducer For Servo Motor	114 - 131
G		SLF□-N SK□-N	低背隙系列 (免鍵式軸套) Low Backlash Type (Clamping Sets)	132 - 133
H			設計參考資料 Engineering Information	134 - 139

訂貨須知

- 機種、型號、馬力
- 減速比或每分鐘回轉數
- 回轉方向和出力軸配置
- 荷重狀況及聯結方式
- 數量及被安裝的機械名稱
- 入力方式和入力轉速

Your Order Shall Kindly Specify

- Type, model and horsepower
- Reduction gear ratio or rpm
- Rotating direction and position of output shaft
- Load and connecting method
- Quantity and the kind of machine applied
- Input method and rpm

■ 二段式分解系統圖 2-Stage System Drawing

■ MODEL : SH(SV)

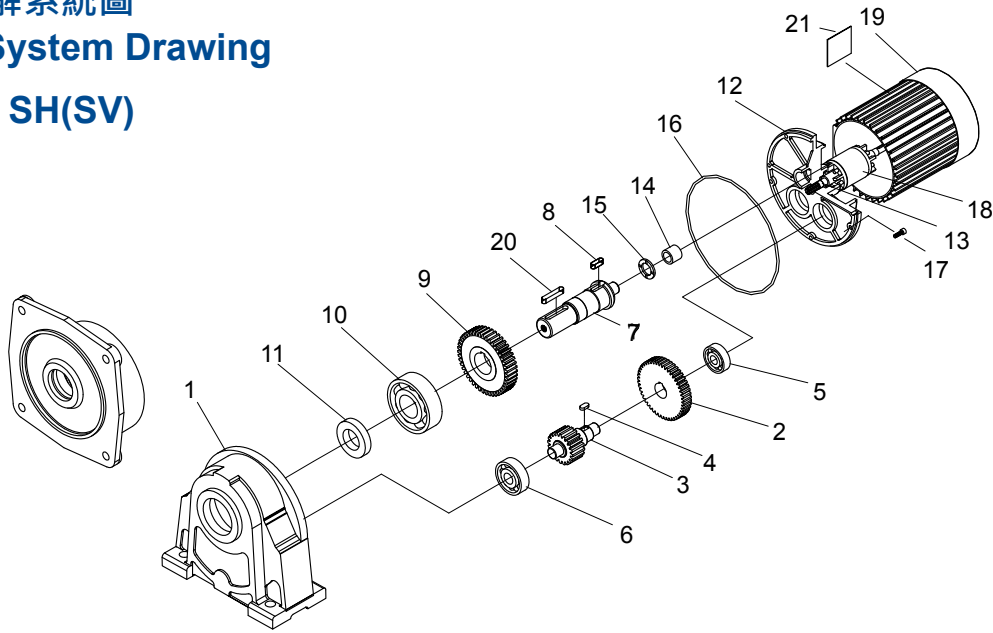

NO.	零件名稱	Name of Parts
1	本體	Body
2	B 齒輪	Gear B
3	C 齒輪	Gear C
4	鍵	Key
5	軸承	Bearing
6	軸承	Bearing
7	出力軸	Output Shaft

NO.	零件名稱	Name of Parts
8	鍵	Key
9	D 齒輪	Gear D
10	軸承	Bearing
11	油封	Oil Seal
12	後蓋	Rear Cover
13	油封	Oil Seal
14	針狀軸承	Needle Bearing

NO.	零件名稱	Name of Parts
15	止推墊片	Washer
16	O 型環	O-Ring
17	固定螺絲	Fixing Screw
18	A 齒輪	Gear A
19	馬達	Motor
20	鍵	Key
21	銘牌	Name Plate

■ 三段式分解系統圖 3-Stage System Drawing

■ MODEL : SH(SV)

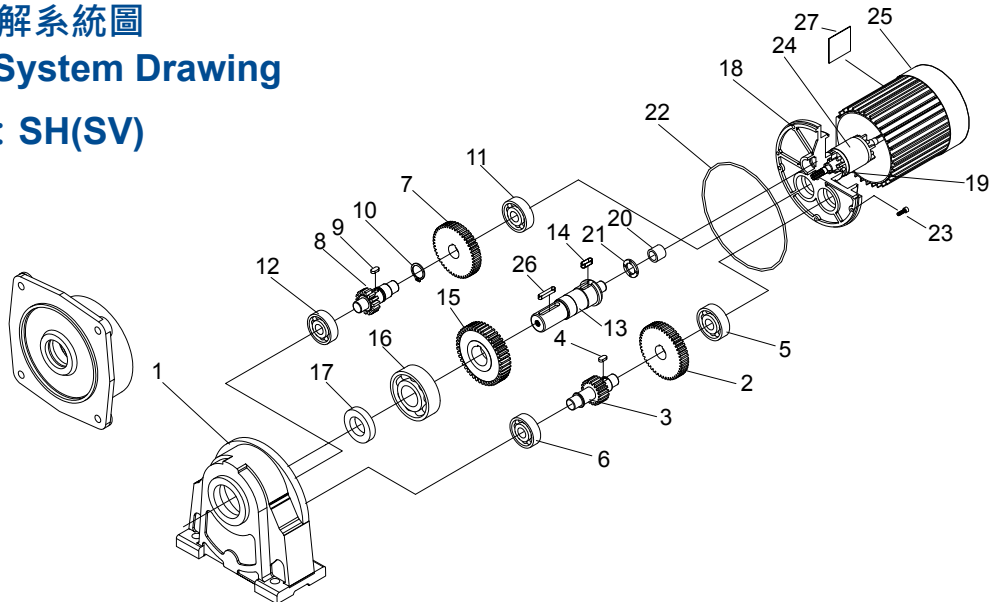

NO.	零件名稱	Name of Parts
1	本體	Body
2	B 齒輪	Gear B
3	E 齒輪	Gear E
4	鍵	Key
5	軸承	Bearing
6	軸承	Bearing
7	F 齒輪	Gear F
8	C 齒輪	Gear C
9	鍵	Key

NO.	零件名稱	Name of Parts
10	扣環	Snap ring
11	軸承	Bearing
12	軸承	Bearing
13	出力軸	Output shaft
14	鍵	Key
15	D 齒輪	Gear D
16	軸承	Bearing
17	油封	Oil seal
18	後蓋	Rear Cover

NO.	零件名稱	Name of Parts
19	油封	Oil seal
20	針狀軸承	Needle Bearing
21	止推墊片	Washer
22	O 型環	O-ring
23	固定螺絲	Fixing screw
24	A 齒輪	Gear A
25	馬達	Motor
26	鍵	Key
27	銘牌	Name plate

SMALL GEAR REDUCER SERIES



■ 臥式減速機 Horizontal Type Reducer

■ MODEL : SH

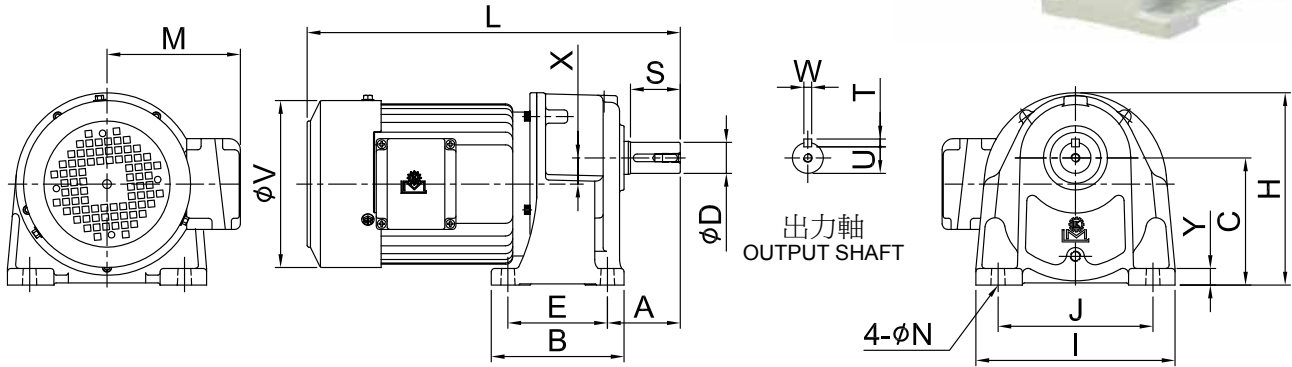

機種型號表示 Indication of Model Numbers

SH	10	1/8	A	1/3
機型 Type	型號 Model	馬力 Horse Power	馬達 Motor	減速比 Ratio
SH	10	1/8 HP	A: 三相 3-Phase	1/5
SHD	11	1/4 HP	B: 剎車 Brake	~
SHB	12	1/2 HP	C: 特殊 Special	1/2000
	13	1 HP	S: 單相 Single Phase	※
	14	2 HP		
	15	3 HP		

出力軸螺絲孔 Output Shaft Screw Hole	
型號 Model	螺絲規格 Screw Specifications
10	M6
11	M6
12	M8
13	M10
14	M12
15	M16

注：SH·SV 系列通用。
NOTE: Common for SL series.

※ 表中減速比以公稱速比，如需實際速比，請另告知。

The reduction ratio in the table are nominal ratios. Please contact us if you need actual ratios.

馬力 Horse Power	型號 Model	減速比 Ratio	A	E	B	J	I	C	H	Y	N	X	L	M	V	出力軸 Output Shaft					重量 Weight (KG)
																D	S	W	T	U	
1/8HP (0.1kW)	10	1/3~1/50 (1/60~1/200)	46	40	65	110	135	85	129	12	9	17	280	108	123	18	30	5	5	15	5
	11	1/6~1/200	57	65	90	130	155	95	145	13	9	17	305	108	123	22	40	7	7	18	7
1/4HP (0.2kW)	10	1/3~1/30 (1/40~1/155)	46	40	65	110	135	85	129	12	9	17	295	115	137	18	30	5	5	15	8
	11	1/3~1/90 (1/95~1/155)	57	65	90	130	155	95	145	13	9	17	315	115	137	22	40	7	7	18	10
1/2HP (0.4kW)	12	1/35~1/200	66	90	120	140	180	115	175	15	11	23	330	115	137	28	45	7	7	24	11
	11	1/3~1/30 (1/35~1/120)	57	65	90	130	155	95	145	13	9	17	325	121	151	22	40	7	7	18	12
	12	1/3~1/90 (1/100~1/200)	66	90	120	140	180	115	175	15	11	23	340	121	151	28	45	7	7	24	13
1HP (0.75kW)	13	1/25~1/200	78	130	165	170	210	130	205	18	13	26	365	121	151	32	55	10	8	27	16
	12	1/3~1/30 (1/40~1/130)	66	90	120	140	180	115	175	15	11	23	360	128	163	28	45	7	7	24	16
	13	1/3~1/90 (1/100~1/165)	78	130	165	170	210	130	205	18	13	26	385	128	163	32	55	10	8	27	19
2HP (1.5kW)	14	1/35~1/180 (1/200)	95	150	195	210	255	150	240	20	15	28	430	128	163	40	65	10	8	35	44
	12	(1/2.5~1/60)	66	90	120	140	180	115	175	15	11	23	395	138	181	28	45	7	7	24	25
	13	1/3~1/25 (1/30~1/130)	78	130	165	170	210	130	205	18	13	26	425	138	181	32	55	10	8	27	28
3HP (2.2kW)	14	1/30~1/90 (1/100~1/170)	95	150	195	210	255	150	240	20	15	28	465	138	181	40	65	10	8	35	46
	15	1/80~1/150 (1/170~1/200)	112	170	225	265	330	185	295	25	19	38	500	138	181	50	80	14	9	44.5	46
	13	(1/3~1/80)	78	130	165	170	210	130	205	18	13	26	465	138	181	32	55	10	8	27	28
	14	1/25~1/50 (1/60~1/170)	95	150	195	210	255	150	240	20	15	28	505	138	181	40	65	10	8	35	46
	15	1/30~1/85 (1/90~1/100)	112	170	225	265	330	185	295	25	19	38	550	190	212	50	80	14	9	44.5	56

注：

- 表中 () 內數字系表示輕荷重使用。
- 表中重量以配合三相 4P 馬達為主，其它單相、剎車、直流、特殊等馬達重量另訂。
- 表中 L、LL 內數字以三相 (剎車) 馬達為主，其它特殊馬達另訂。
- 如需特殊馬達規格，請洽本司業務。
- 以上數值若有變更，恕不另行通知。

NOTE:

- Values shown in parenthesis () are used for light loading.
- Weights shown in the above chart are based on 3-phase 4P motors, weights for single phase, brake, DC, or special motor shall be referred to specific values.
- Values shown in "L" & "LL" column are based on 3-phase (brake) motor, other special motor refer to specific motor refer to specific values.
- For special motor specifications, please contact our business.
- Above specifications are subject to change without prior notice.

小型齒輪減速機系列

A

■ 臥式馬達自裝式減速機 Horizontal Motor-Driver Reducer

■ MODEL : SHB

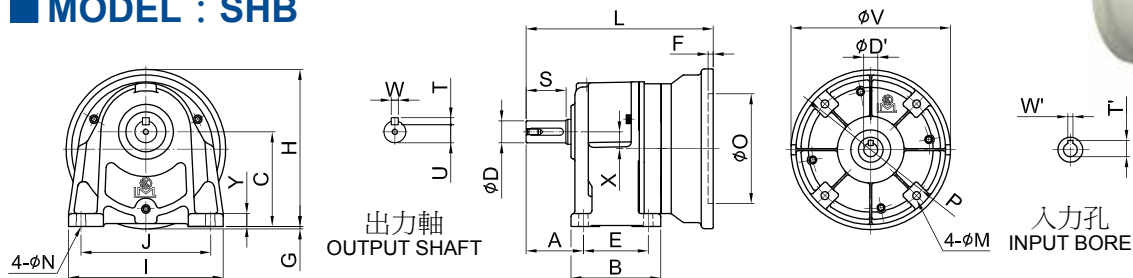

unit: mm

馬力 Horse Power	型號 Model	減速比 Ratio	A	E	B	J	I	C	H	Y	G	N	X	L	F	O	P	M	V	出力軸 Output Shaft					入力孔 Input Bore			重量 Weight (KG)
																				D	S	W	T	U	D'	W'	T'	
1/8HP (0.1kW)	10	1/3~1/50 (1/60~1/200)	46	40	65	110	135	85	148	12	12.4	9	17	161	5	110	130	8	160	18	30	5	5	15	11	4	12.8	3
	11	1/6~1/200	57	65	90	130	155	95	158	13	2.5	9	17	187	5	110	130	8	160	22	40	7	7	18	11	4	12.8	6
1/4HP (0.2kW)	10	1/3~1/30 (1/40~1/155)	46	40	65	110	135	85	148	12	12.4	9	17	161	5	110	130	8	160	18	30	5	5	15	11	4	12.8	3
	11	1/3~1/90 (1/95~1/155)	57	65	90	130	155	95	158	13	2.5	9	17	187	5	110	130	8	160	22	40	7	7	18	11	4	12.8	6
	12	1/35~1/200	66	90	120	140	180	115	174	15	-	11	23	207	5	110	130	8	162	28	45	7	7	24	11	4	12.8	7
1/2HP (0.4kW)	11	1/3~1/30 (1/35~1/120)	57	65	90	130	155	95	158	13	2.5	9	17	187	5	110	130	8	160	22	40	7	7	18	14	5	16.3	5
	12	1/3~1/90 (1/100~1/200)	66	90	120	140	180	115	174	15	-	11	23	207	5	110	130	8	162	28	45	7	7	24	14	5	16.3	7
	13	1/25~1/200	78	130	165	170	210	130	205	18	-	13	26	234	5	110	130	8	162	32	55	10	8	27	14	5	16.3	10
1HP (0.75kW)	12	1/3~1/30 (1/40~1/130)	66	90	120	140	180	115	191	15	9	11	23	222	5	130	165	10	200	28	45	7	7	24	19	6	21.8	6
	13	1/3~1/90 (1/100~1/165)	78	130	165	170	210	130	205	18	-	13	26	249	5	130	165	10	200	32	55	10	8	27	19	6	21.8	10
	14	1/35~1/180 (1/200)	95	150	195	210	255	150	240	20	-	15	28	292	5	130	165	10	200	40	65	10	8	35	19	6	21.8	34
2HP (1.5kW)	12	(1/2.5~1/60)	66	90	120	140	180	115	191	15	9	11	23	232	5	130	165	10	200	28	45	7	7	24	19	6	27.3	7
	13	1/3~1/25 (1/30~1/130)	78	130	165	170	210	130	205	18	-	13	26	259	5	130	165	10	200	32	55	10	8	27	24	8	27.3	10
	14	1/30~1/90 (1/100~1/170)	95	150	195	210	255	150	240	20	-	15	28	302	5	130	165	10	200	40	65	10	8	35	24	8	27.3	34
3HP (2.2kW)	15	1/80~1/150 (1/170~1/200)	112	170	225	265	330	185	295	25	-	19	38	335	5	130	165	10	200	50	80	14	9	44.5	24	8	27.3	36

■ 臥式雙軸式減速機 Horizontal Type Double-Axle Reducer

■ MODEL : SHD

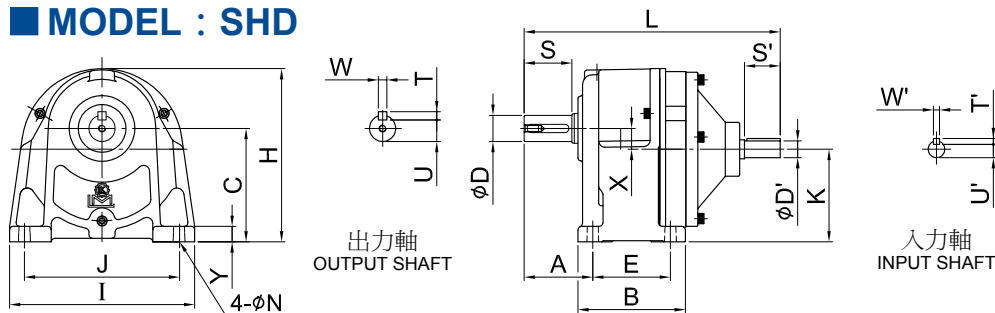

unit: mm

馬力 Horse Power	型號 Model	減速比 Ratio	A	E	B	J	I	C	H	Y	N	X	K	L	出力軸 Output Shaft					入力軸 Input Shaft					重量 Weight (KG)
															D	S	W	T	U	D'	S'	W'	T'	U'	
1/8HP (0.1kW)	10	1/3~1/50 (1/60~1/200)	46	40	65	110	135	85	129	12	9	17	68	167	18	30	5	5	15	11	20	4	4	8.5	3
	11	1/6~1/200	57	65	90	130	155	95	145	13	9	17	78	189	22	40	7	7	18	11	20	4	4	8.5	6
1/4HP (0.2kW)	10	1/3~1/30 (1/40~1/155)	46	40	65	110	135	85	129	12	9	17	68	179	18	30	5	5	15	12	25	4	4	9.5	3
	11	1/3~1/90 (1/95~1/155)	57	65	90	130	155	95	145	13	9	17	78	201	22	40	7	7	18	12	25	4	4	9.5	6
	12	1/35~1/200	66	90	120	140	180	115	175	15	11	23	91	217	28	45	7	7	24	12	25	4	4	9.5	7
1/2HP (0.4kW)	11	1/3~1/30 (1/35~1/120)	57	65	90	130	155	95	145	13	9	17	78	213	22	40	7	7	18	14	30	5	5	11	6
	12	1/3~1/90 (1/100~1/200)	66	90	120	140	180	115	175	15	11	23	91	229	28	45	7	7	24	14	30	5	5	11	7
	13	1/25~1/200	78	130	165	170	210	130	205	18	13	26	104	256	32	55	10	8	27	14	30	5	5	11	10
1HP (0.75kW)	12	1/3~1/30 (1/40~1/130)	66	90	120	140	180	115	175	15	11	23	91	249	28	45	7	7	24	19	35	5	5	16	8
	13	1/3~1/90 (1/100~1/165)	78	130	165	170	210	130	205	18	13	26	104	276	32	55	10	8	27	19	35	5	5	16	11
	14	1/35~1/180 (1/200)	95	150	195	210	255	150	240	20	15	28	122	319	40	65	10	8	35	19	35	5	5	16	33
2HP (1.5kW)	12	(1/2.5~1/60)	66	90	120	140	180	115	175	15	11	23	91	264	28	45	7	7	24	24	40	7	7	20	8
	13	1/3~1/25 (1/30~1/130)	78	130	165	170	210	130	205	18	13	26	104	291	32	55	10	8	27	24	40	7	7	20	11
	14	1/30~1/90 (1/100~1/170)	95	150	195	210	255	150	240	20	15	28	122	334	40	65	10	8	35	24	40	7	7	20	33
3HP (2.2kW)	15	1/80~1/150 (1/170~1/200)	112	170	225	265	330	185	295	25	19	38	146	367	50	80	14	9	44.5	24	40	7	7	20	34
	14	1/25~1/50 (1/60~1/170)	95	150	195	210	255	150	240	20	15	28	122	334	40	65	10	8	35	24	40	7	7	20	33
	15	1/30~1/85 (1/90~1/100)	112	170	225	265	330	185	295	25	19	38	146	396	50	80	14	9	44.5	28	55	7	7	24	34

SMALL GEAR REDUCER SERIES



立式減速機 Vertical Type Reducer

MODEL : SV

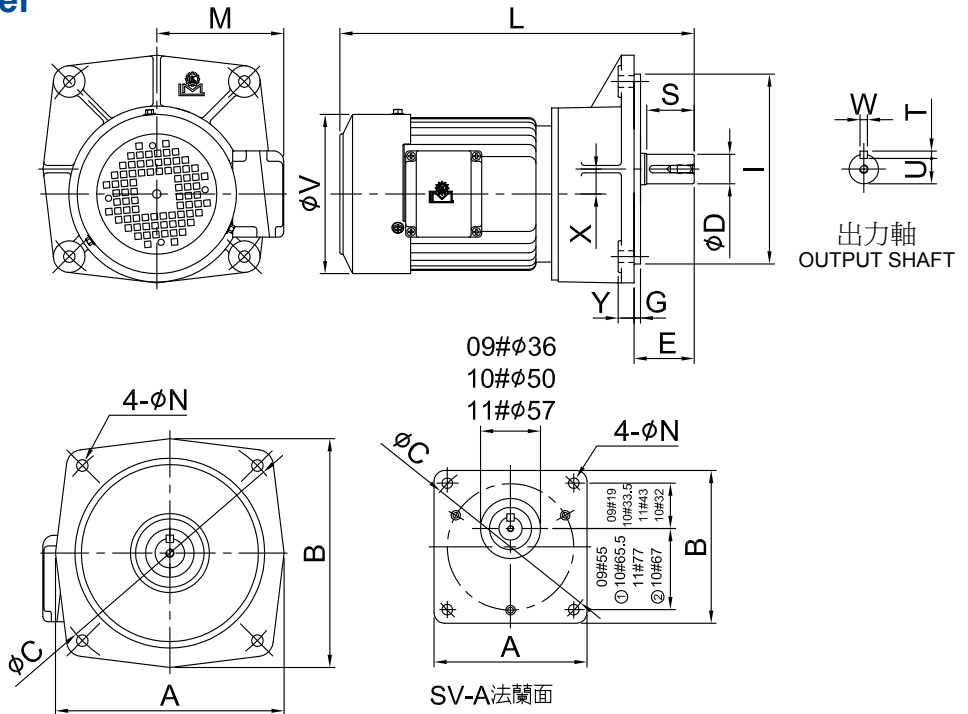

SV(B法蘭面)
型號Model:10,11,12,13,14

SV-A法蘭面

1. 型號Model:09,10,11
有凸托架(WITH CONVEX TRAILER)
2. 型號Model:10
無凸托架(WITHOUT CONVEX TRAILER)

unit: mm

馬力 Horse Power	型號 Model	減速比 Ratio	A	B	C	M	N	I	E	G	Y	X	L	V	出力軸 Output Shaft					重量 Weight (KG)
															D	S	W	T	U	
60W	SV-A09	1/3~1/120 (1/160~1/230)	92	92	104	101	7	-	40	4.5	10.5	18	270	98	12	33	4	4	9.5	4
90W	SV-A09	1/3~1/80 (1/90~1/230)	92	92	104	101	7	-	40	4.5	10.5	18	285	98	15	35	5	5	12	4
1/8HP (0.1kW)	SV-A10	1/3~1/50 (1/60~1/200)	122	122	140	108	9	-	33	-	10	17	280	123	18	30	5	5	15	5
	SV-B10		158	158	170	108	9	120	36	3	10	17	280	123	18	30	5	5	15	5
	SV-A11	1/6~1/200	145	145	170	108	11	-	47	4	12	17	305	123	22	40	7	7	18	7
	SV-11		174	174	185	108	11	140	49	4	12	17	305	123	22	40	7	7	18	7
1/4HP (0.2kW)	SV-A10	1/3~1/30 (1/40~1/155)	122	122	140	115	9	-	33	-	10	17	295	137	18	30	5	5	15	5
	SV-B10		158	158	170	115	9	120	36	3	10	17	295	137	18	30	5	5	15	8
	SV-A11	1/3~1/90 (1/95~1/155)	145	145	170	115	11	-	47	4	12	17	315	137	22	40	7	7	18	10
	SV-11		174	174	185	115	11	140	49	4	12	17	315	137	22	40	7	7	18	10
	12	1/35~1/200	217	217	235	115	11	180	57	6	15	23	330	137	28	45	7	7	24	11
1/2HP (0.4kW)	SV-A11	1/3~1/30 (1/35~1/120)	145	145	170	121	11	-	47	4	12	17	325	151	22	40	7	7	18	12
	SV-11		174	174	185	121	11	140	49	4	12	17	325	151	22	40	7	7	18	12
	12	1/3~1/90 (1/100~1/200)	217	217	235	121	11	180	57	6	15	23	340	151	28	45	7	7	24	13
1HP (0.75kW)	12	1/3~1/30 (1/40~1/130)	217	217	235	128	11	180	57	6	15	23	360	163	28	45	7	7	24	16
	13	1/3~1/90 (1/100~1/165)	250	250	280	128	13	220	65	5	17	26	385	163	32	55	10	8	27	19
	14	1/35~1/180 (1/200)	260	276	310	128	18	230	77	5	20	28	430	163	40	65	10	8	35	44
2HP (1.5kW)	12	(1/2.5~1/60)	217	217	235	138	11	180	57	6	15	23	395	181	28	45	7	7	24	25
	13	1/3~1/25 (1/30~1/130)	250	250	280	138	13	220	65	5	17	26	425	181	32	55	10	8	27	28
	14	1/30~1/90 (1/100~1/170)	260	276	310	138	18	230	77	5	20	28	465	181	40	65	10	8	35	46
3HP (2.2kW)	13	(1/3~1/80)	250	250	280	138	13	220	65	5	17	26	465	181	32	55	10	8	27	28
	14	1/25~1/50 (1/60~1/170)	260	276	310	138	18	230	77	5	20	28	505	181	40	65	10	8	35	46

- 注:
1. 表中 () 內數字系表示輕荷重使用。
 2. 表中重量以配合三相 4P 馬達為主，其它單相、剎車、直流、特殊等馬達重量另訂。
 3. 表中 L、LL 內數字以三相 (剎車) 馬達為主，其它特殊馬達另訂。
 4. 如需特殊馬達規格，請洽本司業務。
 5. 以上數值若有變更，恕不另行通知。

- NOTE:
1. Values shown in parenthesis () are used for light loading.
 2. Weights shown in the above chart are based on 3-phase 4P motors, weights for single phase, brake, DC, or special motor shall be referred to specific values.
 3. Values shown in "L" & "LL" column are based on 3-phase (brake) motor, other special motor refer to specific motor refer to specific values.
 4. For special motor specifications, please contact our business.
 5. Above specifications are subject to change without prior notice.

小型齒輪減速機系列

A

■ 立式馬達自裝式減速機 Vertical Motor-Driver Reducer

■ MODEL : SVB

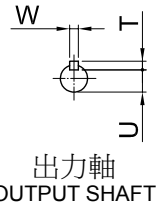
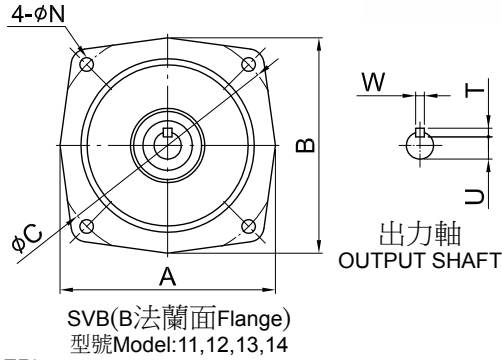
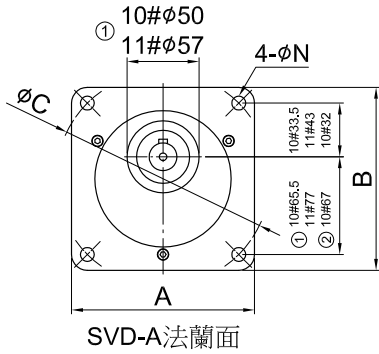

- ① 型號Model:09,10,11有凸托架(WITH CONVEX TRAILER)
- ② 型號Model:10無凸托架(WITHOUT CONVEX TRAILER)

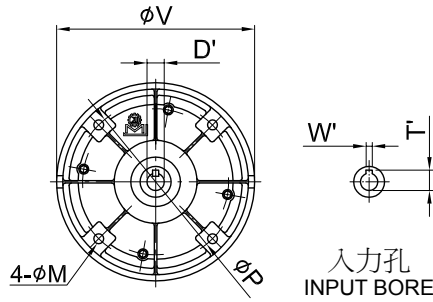
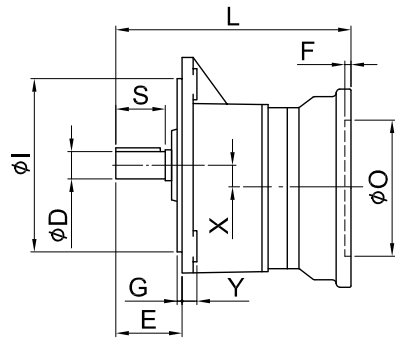

unit: mm

馬力 Horse Power	型號 Model	減速比 Ratio	A	B	C	N	I	E	G	Y	X	L	F	O	P	M	V	出力軸 Output Shaft					入力孔 Input Bore			重量 Weight (KG)
																		D	S	W	T	U	D'	W'	T'	
1/8HP (0.1kW)	SVB-A10	1/3~1/50 (1/60~1/200)	122	122	140	9	-	33	-	10	17	161	5	110	130	8	160	18	30	5	5	15	11	4	12.8	3
	SVB-B10		158	158	170	9	120	36	3	10	17	161	5	110	130	8	160	18	30	5	5	15	11	4	12.8	3
	SVB-A11	1/6~1/200	145	145	170	11	-	47	4	12	17	187	5	110	130	8	160	22	40	7	7	18	11	4	12.8	6
	SVB-11		174	174	185	11	140	49	4	12	17	187	5	110	130	8	160	22	40	7	7	18	11	4	12.8	6
1/4HP (0.2kW)	SVB-A10	1/3~1/30 (1/40~1/155)	122	122	140	9	-	33	-	10	17	161	5	110	130	8	160	18	30	5	5	15	11	4	12.8	3
	SVB-B10		158	158	170	9	120	36	3	10	17	161	5	110	130	8	160	18	30	5	5	15	11	4	12.8	3
	SVB-A11	1/3~1/90 (1/95~1/155)	145	145	170	11	-	47	4	12	17	187	5	110	130	8	160	22	40	7	7	18	11	4	12.8	6
	SVB-11		174	174	185	11	140	49	4	12	17	187	5	110	130	8	160	22	40	7	7	18	11	4	12.8	6
	12	1/35~1/200	217	217	235	11	180	57	6	15	23	207	5	110	130	8	162	28	45	7	7	24	11	4	12.8	7
1/2HP (0.4kW)	SVB-A11	1/3~1/30 (1/35~1/120)	145	145	170	11	-	47	4	12	17	187	5	110	130	8	160	22	40	7	7	18	14	5	16.3	5
	SVB-11		174	174	185	11	140	49	4	12	17	187	5	110	130	8	160	22	40	7	7	18	14	5	16.3	5
	12	1/3~1/90 (1/100~1/200)	217	217	235	11	180	57	6	15	23	207	5	110	130	8	162	28	45	7	7	24	14	5	16.3	7
	13	1/25~1/200	250	250	280	13	220	65	5	17	26	234	5	110	130	8	162	32	55	10	8	27	14	5	16.3	10
1HP (0.75kW)	12	1/3~1/30 (1/40~1/130)	217	217	235	11	180	57	6	15	23	222	5	130	165	10	200	28	45	7	7	24	19	6	21.8	6
	13	1/3~1/90 (1/100~1/165)	250	250	280	13	220	65	5	17	26	249	5	130	165	10	200	32	55	10	8	27	19	6	21.8	10
	14	1/35~1/180 (1/200)	260	276	310	18	230	77	5	20	28	292	5	130	165	10	200	40	65	10	8	35	19	6	21.8	34
2HP (1.5kW)	12	(1/2.5~1/60)	217	217	235	11	180	57	6	15	23	232	5	130	165	10	200	28	45	7	7	24	24	8	27.3	7
	13	1/3~1/25 (1/30~1/130)	250	250	280	13	220	65	5	17	26	259	5	130	165	10	200	32	55	10	8	27	24	8	27.3	10
	14	1/30~1/90 (1/100~1/170)	260	276	310	18	230	77	5	20	28	302	5	130	165	10	200	40	65	10	8	35	24	8	27.3	34



■ 立式雙軸式 Vertical Type Reducer

■ MODEL : SVD

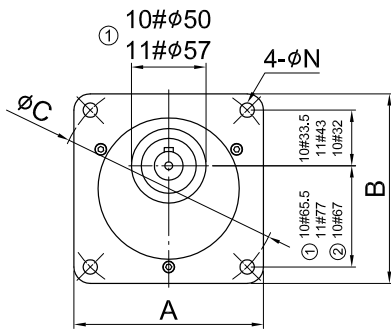

SVD-A法蘭面

- ① 型號Model:09,10,11有凸托架(WITH CONVEX TRAILER)
- ② 型號Model:10無凸托架(WITHOUT CONVEX TRAILER)

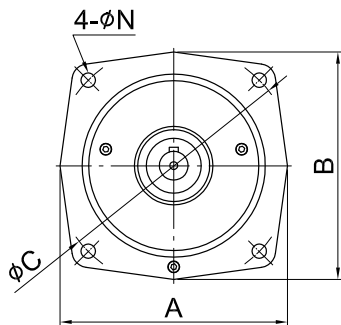

SVD-B法蘭面Flange
型號Model:10,11,12,13,14

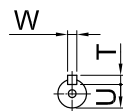

出力軸
OUTPUT SHAFT

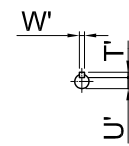
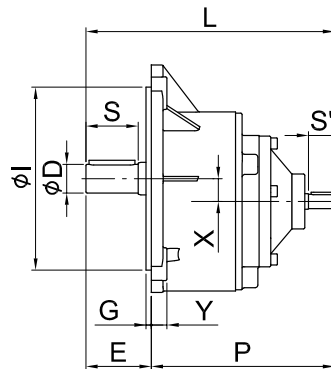

入力軸
INPUT SHAFT

unit: mm

馬力 Horse Power	型號 Model	減速比 Ratio	A	B	C	N	I	X	G	Y	E	P	L	出力軸 Output Shaft					入力軸 Input Shaft					重量 Weight (KG)
														D	S	W	T	U	D'	S'	W'	T'	U'	
1/8HP (0.1kW)	SVD-A10	1/3~1/50 (1/60~1/200)	122	122	140	9	-	17	-	10	33	134	167	18	30	5	5	15	11	20	4	4	8.5	3
	SVD-B10		158	158	170	9	120	17	3	10	36	131	167	18	30	5	5	15	11	20	4	4	8.5	3
	SVD-A11	1/6~1/200	145	145	170	11	-	17	4	12	47	142	189	22	40	7	7	18	11	20	4	4	8.5	6
	SVD-11		174	174	185	11	140	17	4	12	49	140	189	22	40	7	7	18	11	20	4	4	8.5	6
1/4HP (0.2kW)	SVD-A10	1/3~1/30 (1/40~1/155)	122	122	140	9	-	17	-	10	33	146	179	18	30	5	5	15	12	25	4	4	9.5	3
	SVD-B10		158	158	170	9	120	17	3	10	36	143	179	18	30	5	5	15	12	25	4	4	9.5	3
	SVD-A11	1/3~1/90 (1/95~1/155)	145	145	170	11	-	17	4	12	47	154	201	22	40	7	7	18	12	25	4	4	9.5	6
	SVD-11		174	174	185	11	140	17	4	12	49	152	201	22	40	7	7	18	12	25	4	4	9.5	6
	12	1/35~1/200	217	217	235	11	180	23	6	15	57	160	217	28	45	7	7	24	12	25	4	4	9.5	7
1/2HP (0.4kW)	SVD-A11	1/3~1/30 (1/35~1/120)	145	145	170	11	-	17	4	15	47	166	213	22	40	7	7	18	14	30	5	5	11	6
	SVD-11		174	174	185	11	140	17	4	12	49	165	213	22	40	7	7	18	14	30	5	5	11	6
	12	1/3~1/90 (1/100~1/200)	217	217	235	11	180	23	6	15	57	172	229	28	45	7	7	24	14	30	5	5	11	7
	13	1/25~1/200	250	250	280	13	220	26	5	17	65	191	256	32	55	10	8	27	14	30	5	5	11	10
1HP (0.75kW)	12	1/3~1/30 (1/40~1/130)	217	217	235	11	180	23	6	15	57	192	249	28	45	7	7	24	19	35	5	5	16	8
	13	1/3~1/90 (1/100~1/165)	250	250	280	13	220	26	5	17	65	211	276	32	55	10	8	27	19	35	5	5	16	11
	14	1/35~1/180 (1/200)	260	276	310	18	230	28	5	20	77	242	319	40	65	10	8	35	19	35	5	5	16	34
2HP (1.5kW)	12	(1/2.5~1/60)	217	217	235	11	180	23	6	15	57	207	264	28	45	7	7	24	24	40	7	7	20	8
	13	1/3~1/25 (1/30~1/130)	250	250	280	13	220	26	5	17	65	226	291	32	55	10	8	27	24	40	7	7	20	11
	14	1/30~1/90 (1/100~1/170)	260	276	310	18	230	28	5	20	77	257	334	40	65	10	8	35	24	40	7	7	20	34
3HP (2.2kW)	14	1/25~1/50 (1/60~1/170)	260	276	310	18	230	28	5	20	77	257	334	40	65	10	8	35	24	40	7	7	20	34

小型齒輪減速機系列

A

■ 臥式多速比減速機 Horizontal High Reduction Gear Reducer

■ MODEL : SHL

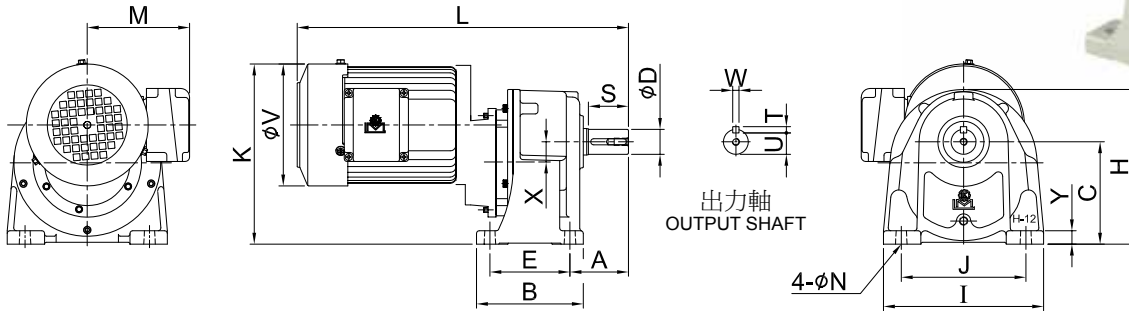

最大容許扭力 Max. Permissible Torque					
型號 Model No.	11	12	13	14	15
扭力 Torque kg-m	10	20	40	75	110

unit: mm

馬力 Horse Power	型號 Model	減速比 Ratio	A	E	B	J	I	C	H	Y	N	X	L	M	V	K	出力軸 Output Shaft					重量 Weight (KG)
																	D	S	W	T	U	
1/8HP (0.1kW)	11	1/200~1/2000	57	65	90	130	155	95	145	13	9	17	350	112	123	180	22	40	7	7	18	12
1/4HP (0.2kW)	12		66	90	120	140	180	115	175	15	11	23	375	118	137	210	28	45	7	7	24	14
1/2HP (0.4kW)	13		78	130	165	170	210	130	205	18	13	26	425	109	151	240	32	55	10	8	27	19
1HP (0.75kW)	14		95	150	195	210	255	150	240	20	15	28	490	114	163	275	40	65	10	8	35	48
2HP (1.5kW)	15	1/280~1/700	112	170	225	265	330	185	295	25	19	38	565	127	181	295	50	80	14	9	44.5	50

注：多速比減速機以定轉速設計，請參考齒箱最大容許扭力。

NOTE: This multistage gear reducer is designed to rotate at fixed speed. Please refer to the maximum allowable torque of the gear box.

■ 臥式多速比雙軸減速機 Horizontal High Gear Reducer

■ MODEL : SHDL

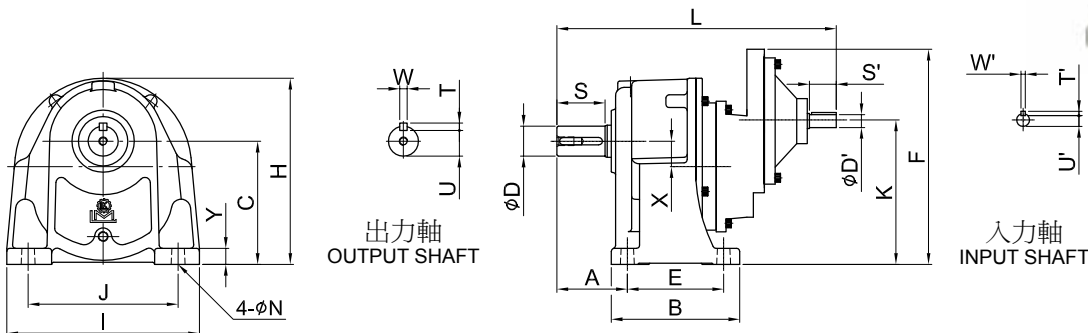

unit: mm

馬力 Horse Power	型號 Model	減速比 Ratio	A	E	B	J	I	C	H	Y	N	X	K	L	F	出力軸 Output Shaft					入力軸 Input Shaft					重量 Weight (KG)
																D	S	W	T	U	D'	S'	W'	T'	U'	
1/8HP (0.1kW)	11	1/200~1/2000	57	65	90	130	155	95	145	13	9	17	114	237	175	22	40	7	7	18	11	20	4	4	8.5	9
1/4HP (0.2kW)	12		66	90	120	140	180	115	175	15	11	23	137	263	205	28	45	7	7	24	12	28	4	4	9.5	10
1/2HP (0.4kW)	13		78	130	165	170	210	130	205	18	13	26	159	315	230	32	55	10	8	27	14	30	5	5	11	13
1HP (0.75kW)	14		95	150	195	210	255	150	240	20	15	28	188	380	265	40	65	10	8	35	19	35	5	5	16	34
2HP (1.5kW)	15	1/280~1/700	112	170	225	265	330	185	295	25	19	38	201	432	289	50	80	14	9	44.5	24	40	7	7	20	36

注：多速比減速機以定轉速設計，請參考齒箱最大容許扭力。

NOTE: This multistage gear reducer is designed to rotate at fixed speed. Please refer to the maximum allowable torque of the gear box.

■ 立式多速比減速機 Vertical High Reduction Gear Reducer

■ MODEL : SVL

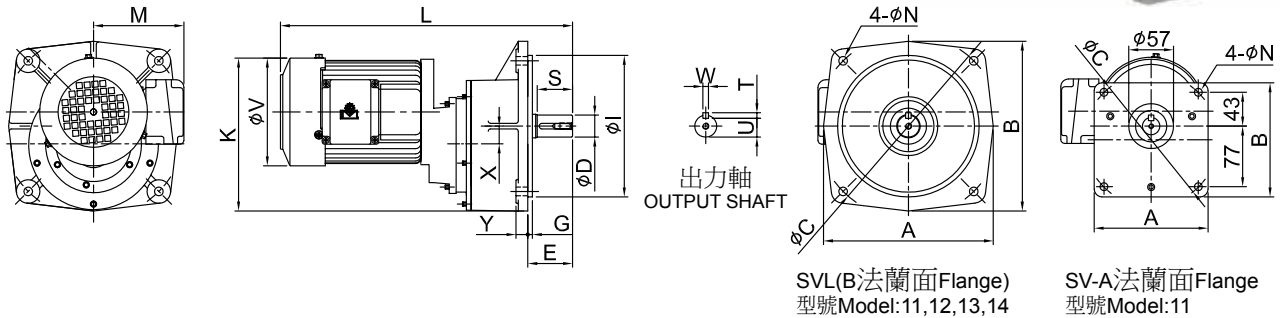

unit: mm

馬力 Horse Power	型號 Model	減速比 Ratio	A	B	C	M	N	I	E	G	Y	X	L	V	K	出力軸 Output Shaft					重量 Weight (KG)
																D	S	W	T	U	
1/8HP (0.1kW)	SVL-A11	1/200~1/2000	145	145	170	112	11	-	47	4	12	17	350	123	175	22	40	7	7	18	12
	SVL-11		174	174	185	112	11	140	49	4	12	17	350	123	170	22	40	7	7	18	12
1/4HP (0.2kW)	12		217	217	235	118	11	180	57	6	15	23	375	137	200	28	45	7	7	24	14
1/2HP (0.4kW)	13		250	250	280	109	13	220	65	5	17	26	425	151	235	32	55	10	8	27	19
1HP (0.75kW)	14		260	276	310	114	18	230	77	5	20	28	490	163	265	40	65	10	8	35	48

注：多速比減速機以定轉速設計，請參考齒箱最大容許扭力。

NOTE: This multistage gear reducer is designed to rotate at fixed speed. Please refer to the maximum allowable torque of the gear box.

■ 立式多速比雙軸減速機 Vertical High Reduction Double-Axle Gear Reducer

■ MODEL : SVDL

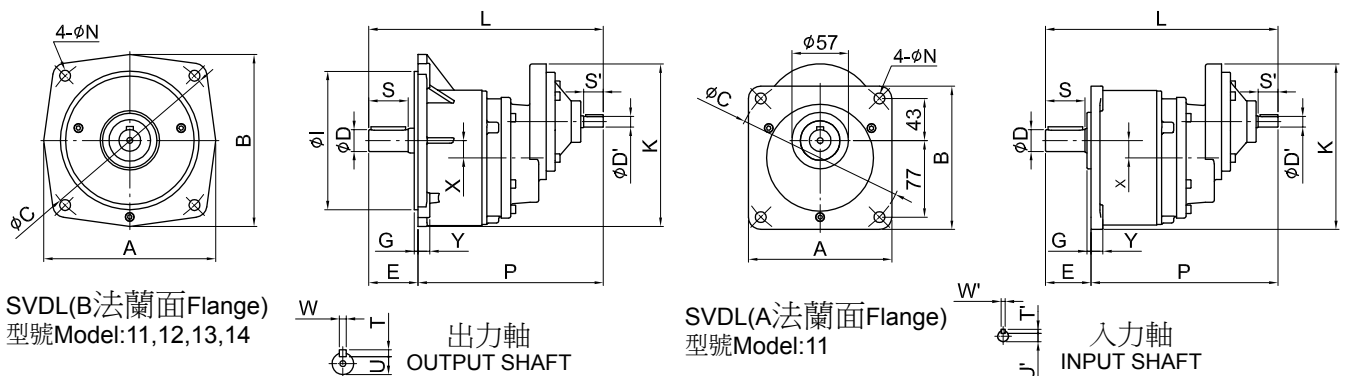

unit: mm

馬力 Horse Power	型號 Model	減速比 Ratio	A	B	C	N	I	X	G	Y	E	P	L	K	出力軸 Output Shaft					入力軸 Input Shaft					重量 Weight (KG)
															D	S	W	T	U	D'	S'	W'	T'	U'	
1/8HP (0.1kW)	SVDL-A11	1/200~1/2000	145	145	170	11	-	17	4	12	47	190	237	167	22	40	7	7	18	11	20	4	4	8.5	9
	SVDL-11		174	174	185	11	140	17	4	12	49	189	237	165	22	40	7	7	18	11	20	4	4	8.5	9
1/4HP (0.2kW)	12		217	217	235	11	180	23	6	15	57	206	263	194	28	45	7	7	24	12	25	4	4	9.5	10
1/2HP (0.4kW)	13		250	250	280	13	220	26	5	17	65	251	316	224	32	55	10	8	27	14	30	5	5	11	13
1HP (0.75kW)	14		260	276	310	18	230	28	5	20	77	303	380	258	40	65	10	8	35	19	35	5	5	16	37

注：多速比減速機以定轉速設計，請參考齒箱最大容許扭力。

NOTE: This multistage gear reducer is designed to rotate at fixed speed. Please refer to the maximum allowable torque of the gear box.

■ 臥式高速比多段減速機

Horizontal High Gear Ratio & Multi-Stage Reducemodel

■ MODEL : SHLS

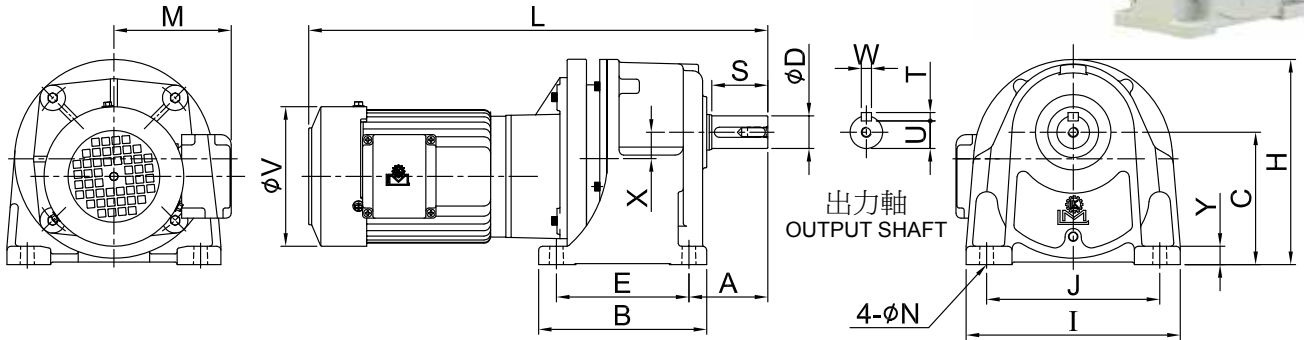

unit: mm

馬力 Horse Power	型號 Model	減速比 Ratio	A	E	B	J	I	C	H	Y	N	X	L	M	V	出力軸 Output Shaft					重量 Weight (KG)
																D	S	W	T	U	
60W	11	1/2000 以上	57	65	90	130	155	95	145	13	9	17	380	101	98	22	40	7	7	18	10
90W	11		57	65	90	130	155	95	145	13	9	17	395	101	98	22	40	7	7	18	10
1/8HP (0.1kW)	12		66	90	120	140	180	115	175	15	11	23	415	108	123	28	45	7	7	24	12
1/4HP (0.2kW)	13		78	130	165	170	210	130	205	18	13	26	455	115	137	32	55	10	8	27	18
1/2HP (0.4kW)	14		95	150	195	210	255	150	240	20	15	28	520	121	151	40	65	10	8	35	35
1HP (0.75kW)	15		112	170	225	265	330	185	295	25	19	38	585	128	163	50	80	14	9	44.5	54

注：多速比減速機以定轉速設計，請參考齒箱最大容許扭力。

NOTE: This multistage gear reducer is designed to rotate at fixed speed. Please refer to the maximum allowable torque of the gear box.

■ 立式高速比多段減速機

Vertical High Gear Ratio & Multi-Stage Reducer

■ MODEL : SVLS

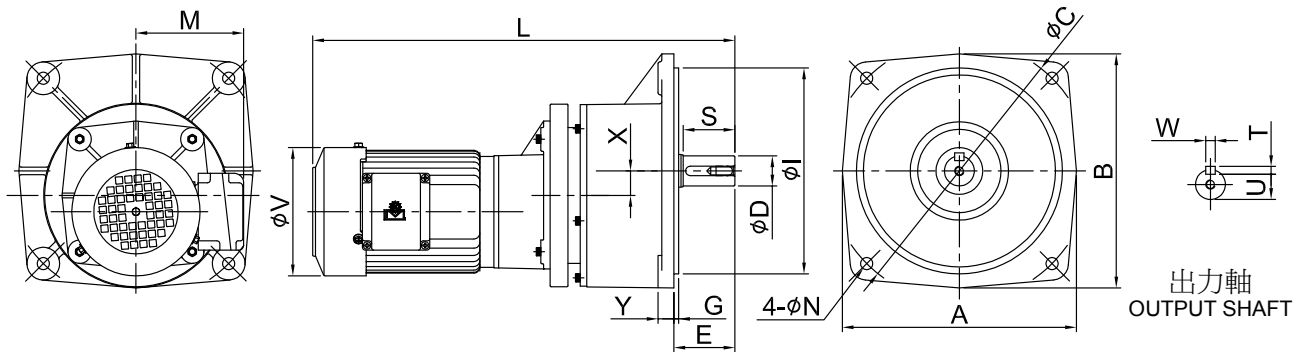

unit: mm

馬力 Horse Power	型號 Model	減速比 Ratio	A	B	C	M	N	I	E	G	Y	X	L	V	出力軸 Output Shaft					重量 Weight (KG)
															D	S	W	T	U	
60W	SVLS-A11	1/2000 以上	145	145	170	101	11	-	47	4	12	17	380	98	22	40	7	7	18	10
	SVLS-11		174	174	185	101	11	140	49	4	12	17	380	98	22	40	7	7	18	10
90W	SVLS-A11		145	145	170	101	11	-	47	4	12	17	395	98	22	40	7	7	18	10
	SVLS-11		174	174	185	101	11	140	49	4	12	17	395	98	22	40	7	7	18	10
1/8HP (0.1kW)	12		217	217	235	108	11	180	57	6	15	23	415	123	28	45	7	7	24	12
1/4HP (0.2kW)	13		250	250	280	115	13	220	65	5	17	26	455	137	32	55	10	8	27	18
1/2HP (0.4kW)	14	260	276	310	121	18	230	77	5	20	28	520	151	40	65	10	8	35	35	

注：多速比減速機以定轉速設計，請參考齒箱最大容許扭力。

NOTE: This multistage gear reducer is designed to rotate at fixed speed. Please refer to the maximum allowable torque of the gear box.

■ 中空軸蝸輪減速機 Hollow Output Shaft Worm Gear Reducer

■ MODEL : SEOM

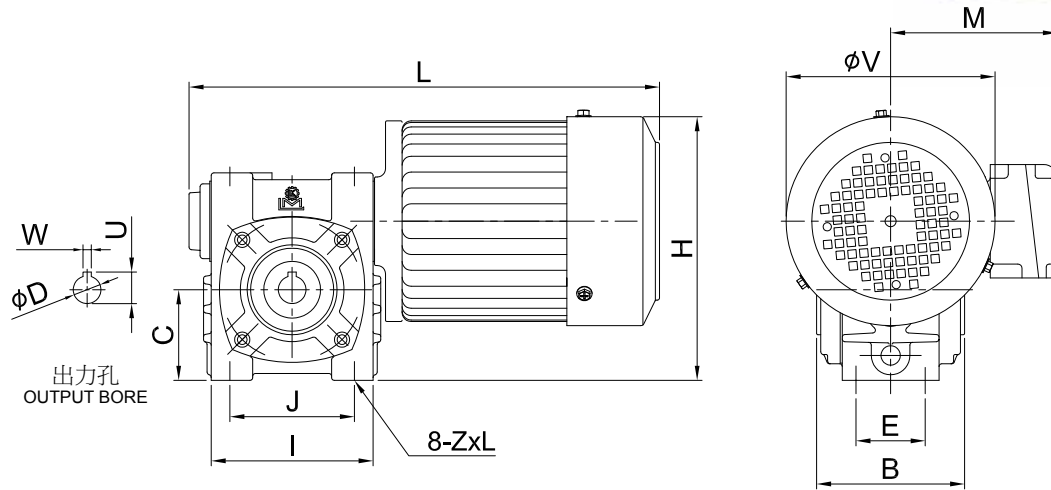

unit: mm

馬力 Horse Power	型號 Model	減速比 Ratio	E	B	J	I	C	H	L	M	V	ZxL	出力孔 Output Bore			重量 Weight (KG)
													W	D	U	
1/4HP (0.2kW)	50	1/5~1/60	50	98	90	115	65	185	335	115	137	M8x16	6	20	22.8	13
1/2HP (0.4kW)	50	1/5~1/40(1/50~1/60)	50	98	90	115	65	195	340	121	151	M8x16	6	20	22.8	15
	60	1/5~1/60	55	108	100	125	75	215	355	121	151	M10x18	8	25	28.3	18
1HP (0.75kW)	60	(1/5~1/30)	55	108	100	125	75	220	370	128	163	M10x18	8	25	28.3	20
	70	1/5~1/40(1/50~1/60)	65	128	125	158	85	240	405	128	163	M10x18	8	30	33.3	24

■ 防水型蝸輪減速機 Waterproof Worm Gear Reducer

■ MODEL : SEOM

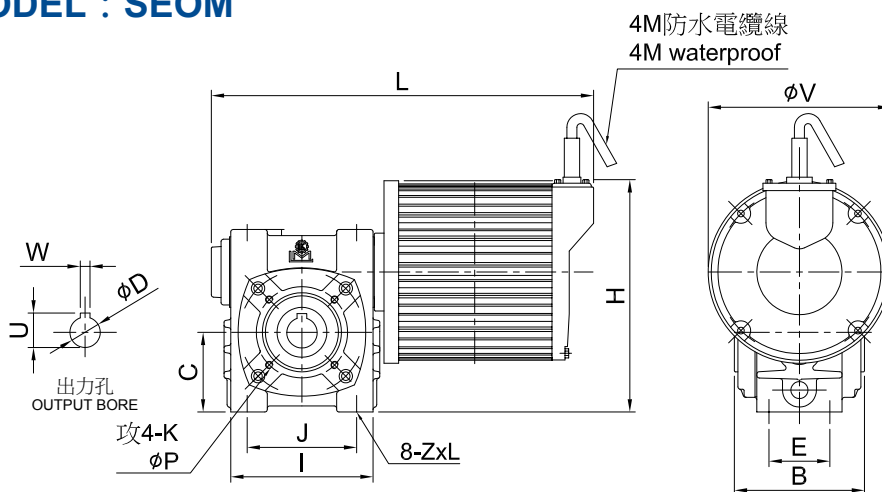

unit: mm

馬力 Horse Power	型號 Model	減速比 Ratio	E	B	J	I	C	H	L	V	K	P	ZxL	出力孔 Output Bore			重量 Weight (KG)
														W	D	U	
1/2HP (0.4kW)	50	1/5~1/40(1/50~1/60)	50	107	90	115	65	190	315	150	M6	76	M8x16	8	25	28.5	15
1HP (0.75kW)	60	(1/5~1/30)	50	110	100	125	75	210	350	150	M8	92	M10x18	8	30	33.5	20

小型齒輪減速機系列

B

■ 小型蝸輪減速機 Hollow Output Shaft Worm Gear Reducer

■ MODEL : SNEOM

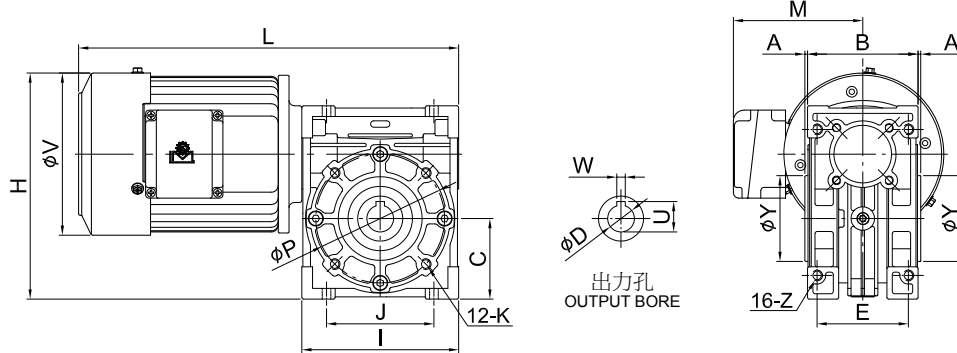
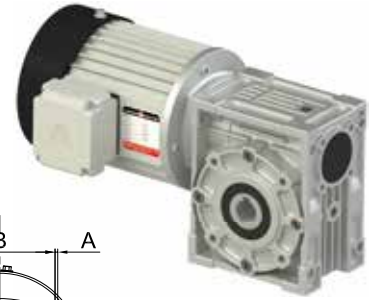

unit: mm

馬力 Horse Power	型號 Model	減速比 Ratio	A	E	B	J	I	C	H	Y	L	M	V	K	P	Z	出力孔 Output Bore			重量 Weight (KG)
																	W	D	U	
1/8HP (0.1kW)	30	1/5~1/40(1/50~1/60)	2	45	60	55	80	40	132	55	265	108	123	M6	65	M6	5	14	16.3	5
1/4HP (0.2kW)	30	1/5~1/20(1/30~1/60)	2	45	60	55	80	40	139	55	275	115	137	M6	65	M6	5	14	16.3	5.5
1/8HP (0.1kW)	40	1/5~1/60	2	60	80	70	102	50	155	60	295	108	123	M6	77	M8	6	20	22.8	6.5
1/4HP (0.2kW)	40	1/5~1/40(1/50~1/60)	2	60	80	70	102	50	160	60	305	115	137	M6	77	M8	6	20	22.8	8
1/2HP (0.4kW)	40	1/5~1/10(1/20~1/30)	2	60	80	70	102	50	170	60	310	121	151	M6	77	M8	6	20	22.8	9
1/4HP (0.2kW)	50	1/5~1/40(1/50~1/60)	3	70	94	80	120	60	180	70	325	115	137	M6	95	M10	8	25	28.3	9.5
1/2HP (0.4kW)	50	1/5~1/30(1/40~1/60)	3	70	94	80	120	60	190	70	330	121	151	M6	95	M10	8	25	28.3	10.5
1HP (0.75kW)	50	1/5(1/10~1/20)	3	70	94	80	120	60	195	70	350	128	163	M6	95	M10	8	25	28.3	13.5
1/2HP (0.4kW)	60	1/5~1/60	3	85	102	100	146	75	215	80	355	121	151	M8	120	M10	8	25	28.3	12.5
1HP (0.75kW)	60	(1/5~1/40)	3	85	102	100	146	75	220	80	375	128	163	M8	120	M10	8	25	28.3	15.5
1/2HP (0.4kW)	70	1/5~1/60	3	90	118	120	170	85	235	90	385	121	151	M10	140	M10	8	30	33.3	17
1HP (0.75kW)	70	1/5~1/40(1/50~1/60)	3	90	118	120	170	85	240	90	405	128	163	M10	140	M10	8	30	33.3	20
2HP (1.5kW)	70	1/5~1/10(1/15~1/30)	3	90	118	120	170	85	250	90	440	138	181	M10	140	M10	8	30	33.3	25

- 注：
- 表中 () 內數字系表示輕荷重使用。
 - 表中重量以配合三相 4P 馬達為主，其它單相、剎車、直流、特殊等馬達重量另訂。
 - 表中 L 內數字以三相馬達為主，其它特殊馬達另訂。
 - 如需特殊馬達規格，請洽本公司業務。
 - 以上數值若有變更，恕不另行通知。

- NOTE:
- Values shown in paranthesis () are used for light loading.
 - Weights shown in the above chart are based on 3-phase 4P motors, weights for single phase, brake, DC, or special motor shall be referred to specific values.
 - Values shown in 'L' column are based on 3-phase motor, other special motor Refer to specific motor refer to specific values.
 - For special motor specifications, please contact our business.
 - Above specifications are subject to change without prior notice.

■ 小型蝸輪減速機 Small Worm Reducer

■ MODEL : SMW28

unit: mm

馬力 Horse Power	型號 Model	減速比 Ratio	A	B
25W	28	1/5~1/60	186	80
40W	28		191	88
60W	28		216	90

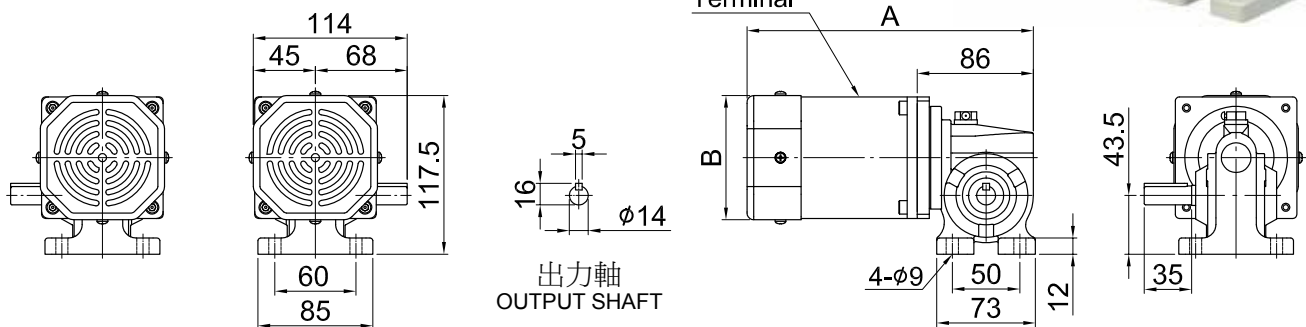

出力軸左方圖
LEFT SHAFT

出力軸右方圖
RIGHT SHAFT

■ 小型蝸輪減速機 Small Worm Reducer

■ MODEL : SMW

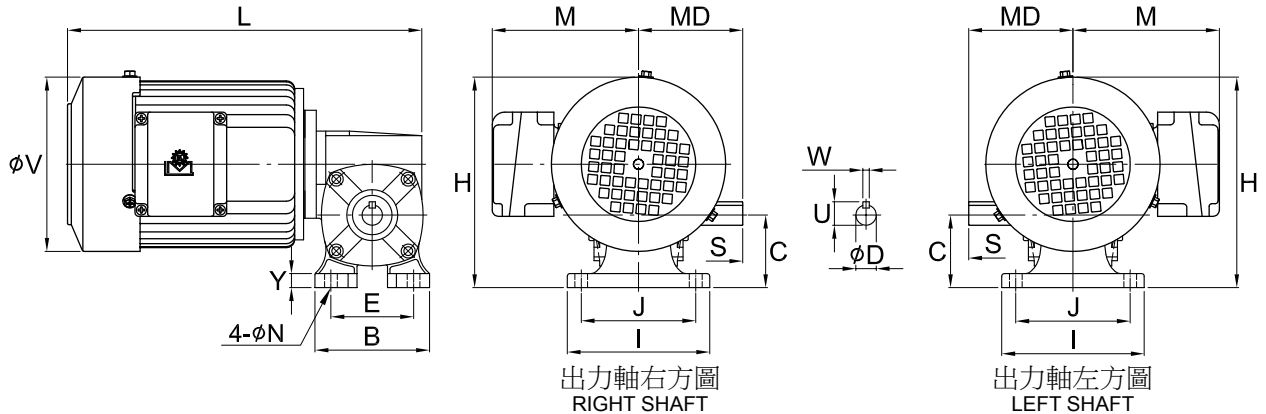

unit: mm

馬力 Horse Power	型號 Model	減速比 Ratio	L	V	M	H	E	B	J	I	Y	C	N	MD	出力軸 Output Shaft				重量 Weight (KG)
															D	S	W	U	
1/8HP (0.1kW)	40	1/5~1/60	275	123	108	160	65	92	90	112	11	56.5	10	82	16	40	5	18	6
1/4HP (0.2kW)	40	1/5~1/50(1/60)	285	137	115	170	65	92	90	112	11	56.5	10	82	16	40	5	18	7
1/2HP (0.4kW)	40	(1/5~1/30)	290	151	121	175	65	92	90	112	11	56.5	10	82	16	40	5	18	9
	50	1/5~1/60	340	151	121	210	120	150	105	130	15	80	11	106	22	50	7	25	16

■ 小型蝸輪減速機 Small Worm Reducer

■ MODEL : SAM50

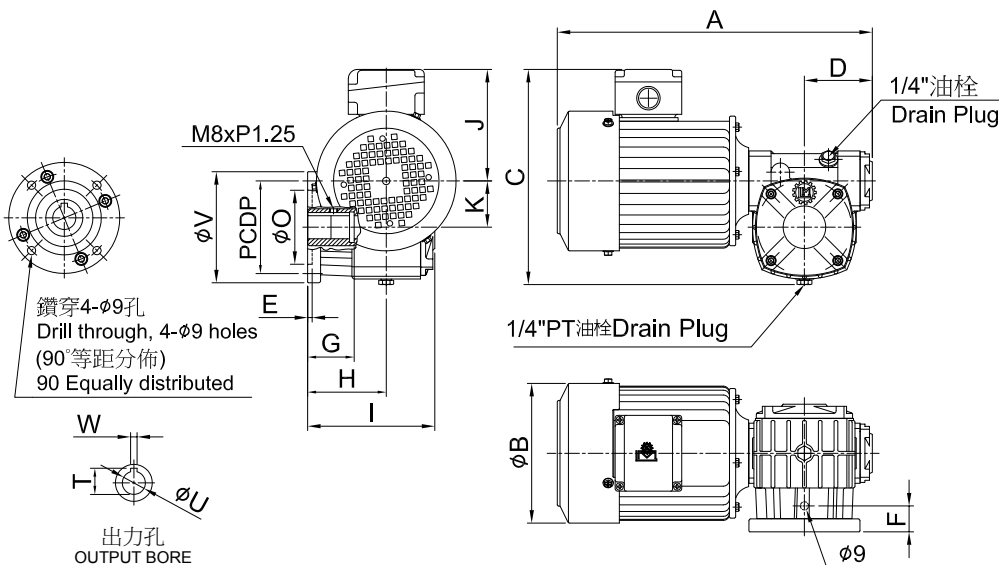

unit: mm

馬力 Horse Power	型號 Model	減速比 Ratio	A	B	C	D	E	F	G	H	I	J	K	V	P	O	出力孔 Output Bore			重量 Weight (KG)
																	W	T	U	
1/8HP (0.1kW)	50	1/5~1/60	325	123	225	73.3	5	28	50.3	85	140	108	50	120	100	80	7	28.3	25	10
1/4HP (0.2kW)		1/5~1/40(1/50~1/60)	335	137	230	73.3	5	28	50.3	85	140	115	50	120	100	80	7	28.3	25	12
1/2HP (0.4kW)		1/5~1/30(1/40~1/60)	345	151	235	73.3	5	28	50.3	85	140	121	50	120	100	80	7	28.3	25	14

SAM50 安裝方向 Installation Direction For SAM50

- 正常的使用方向可以使減速機保持較高的壽命。
The life time of gear reducer can be prolonged in proper direction.
- 安裝時請注意油面計、注油栓及排油栓的位置以備日後維護。
Please note the positions of oil gauge, oil filling plug and oil drain plug to facilitate the maintenance afterwards.
- 減速機使用方向特殊時，請與我們連繫。
For special installation direction, please contact us.

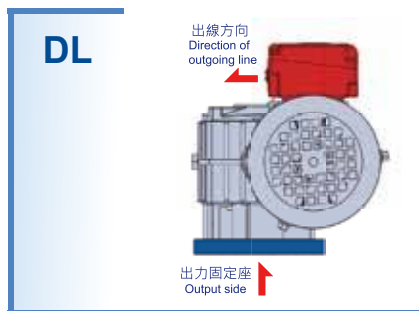
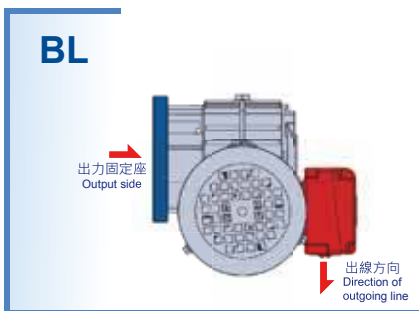
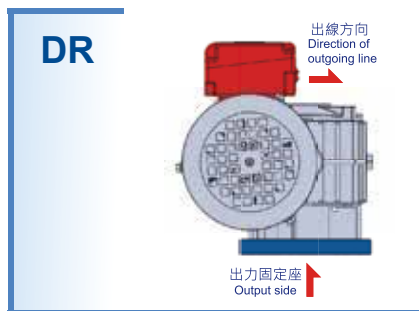
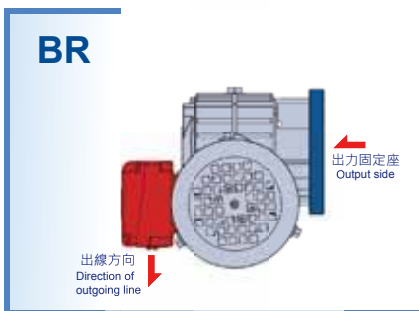
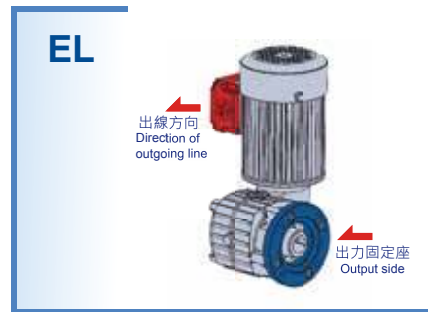
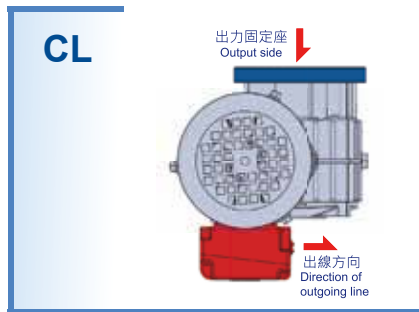
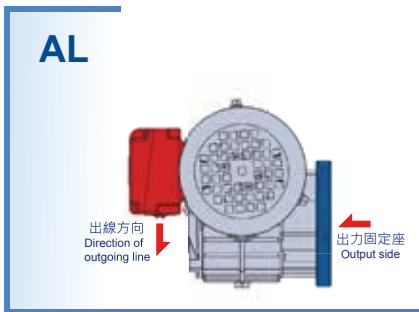
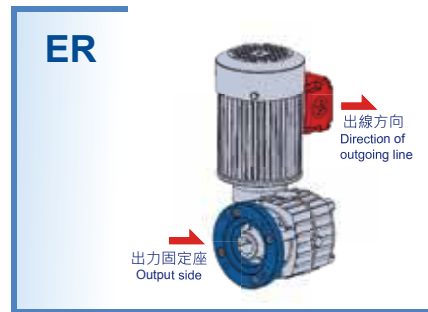
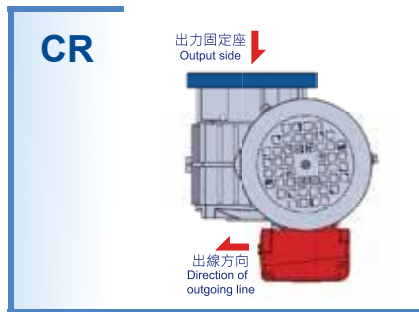
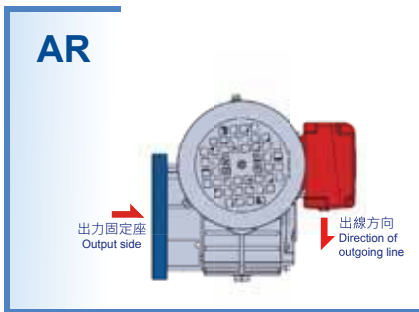

小型戟齒減速機

Small Hypoid Gear Reducer

SLH



SLF-O

SLF-D























機種型號表示 Indication of Model Numbers

SLH	□	10		1/8	A	1/5
SLF	□	10	O	1/8	A	1/5
機型 Type	機種 Type	型號 Model	出力軸表示 Output	馬力 Horse Power	馬達 Motor	減速比 Ratio
SLH	□: 無 None	09	O: 中空軸 Hollow Shaft	60W	A: 三相 3-Phase	1/5
SLF	B: 自裝式 Motor-Driver	11	D: 實心軸 Solid Shaft	90W	B: 剎車 Brake	~
	D: 雙軸式 Double-Axle	12		1/8 HP	C: 特殊 Special	1/2500
	L: 多速比 High Reduction	13		1/4 HP	S: 單相 Single Phase	
	BL: 多速比自裝式 High Reduction Motor-Driver	14		1/2 HP		※
	DL: 多速比雙軸式 High Reduction Double-Axle			1 HP		
				2 HP		
				3 HP		

※ 表中減速比以公稱速比，如需實際速比，請另告知。The reduction ration in the table are nominal ratios. Please contact us if your need actual ratios.

■ 產品樣式選擇 Selection Of Type

	SLH 臥式 Horizontal	SLF - O 法蘭中空軸式 Flange Solid Shaft	SLF - D 法蘭實心軸式 Flange Hollow Shaft
 標準型 Standard			
B 自裝式 Motor Driver	SLH 	SLF-O 	SLF-D 
D 雙軸式 Double Axle	SLHB 	SLFB-O 	SLFB-D 
L 多速比 High Reduction	SLHD 	SLFD-O 	SLFD-D 
BL 多速比自裝式 High Reduction Motor Driver	SLHL 	SLFL-O 	SLFL-D 
DL 多速比雙軸式 High Reduction Double Axle	SLHBL 	SLFBL-O 	SLFBL-D 
	SLHDL 	SLFDL-O 	SLFDL-D 



■ 減速機安裝方向
Reducer Installation Direction

■ MODEL : SLH

代號 Code	示意圖 Schematic Diagram
H1	
H2	
H3	

代號 Code	示意圖 Schematic Diagram
H4	
H5	

■ 減速機線盒方向
Reducer Terminal Box Direction

代號 Code	示意圖 Schematic Diagram
盒上 UP	
盒左 LEFT	

代號 Code	示意圖 Schematic Diagram
盒下 DOWN	
盒右 RIGHT	



■ 減速機安裝方向 Reducer Installation Direction

■ MODEL : SLF

代號 Code	示意圖 Schematic Diagram
F1	
F2	
F3	

代號 Code	示意圖 Schematic Diagram
F4	
F5	

■ 減速機線盒方向 Reducer Terminal Box Direction

代號 Code	示意圖 Schematic Diagram
盒上 UP	
盒左 LEFT	

代號 Code	示意圖 Schematic Diagram
盒下 DOWN	
盒右 RIGHT	

■ 二段式分解系統圖

2-Stage System Drawing

■ MODEL : SLH

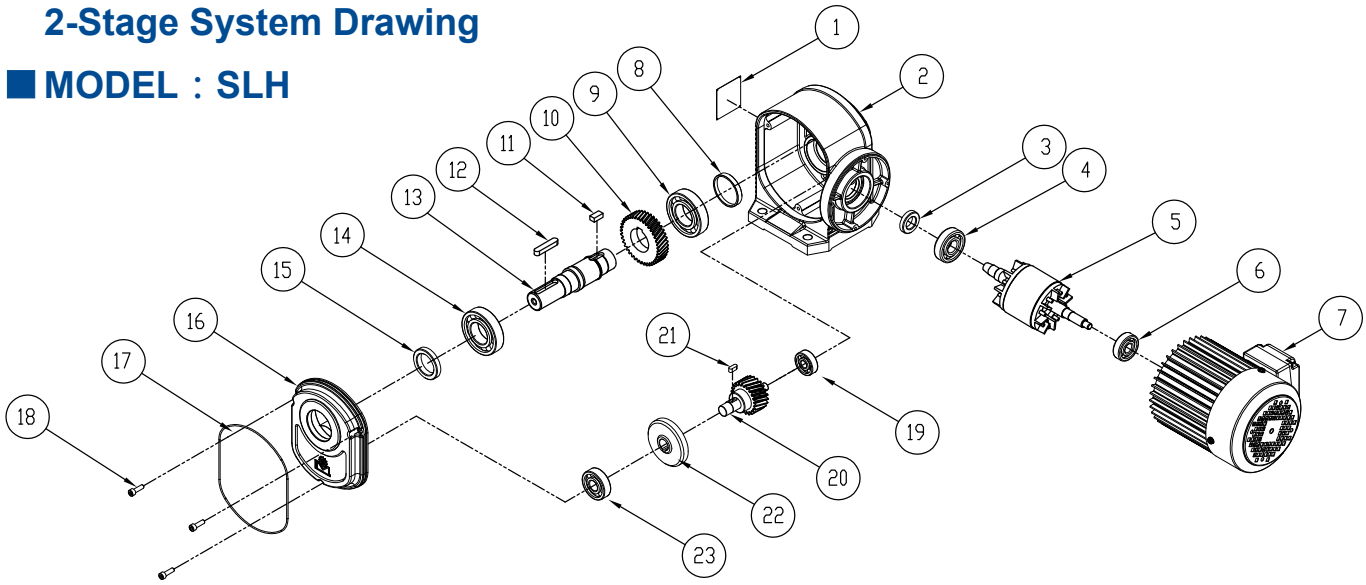

NO.	零件名稱	Name of Parts
1	銘牌	Name Plate
2	本體	Body
3	油封	Oil Seal
4	軸承	Bearing
5	A 齒輪	Gear A
6	軸承	Bearing
7	馬達	Motor
8	油封	Oil Seal

NO.	零件名稱	Name of Parts
9	軸承	Bearing
10	D 齒輪	Gear D
11	鍵	Key
12	鍵	Key
13	出力軸	Output Shaft
14	軸承	Bearing
15	油封	Oil Seal
16	本體蓋	Body Cover

NO.	零件名稱	Name of Parts
17	O 型環	O-Ring
18	固定螺絲	Fixing Screw
19	軸承	Bearing
20	C 齒輪	Gear C
21	鍵	Key
22	B 齒輪	Gear B
23	軸承	Bearing

■ 三段式分解系統圖

3-Stage System Drawing

■ MODEL : SLH

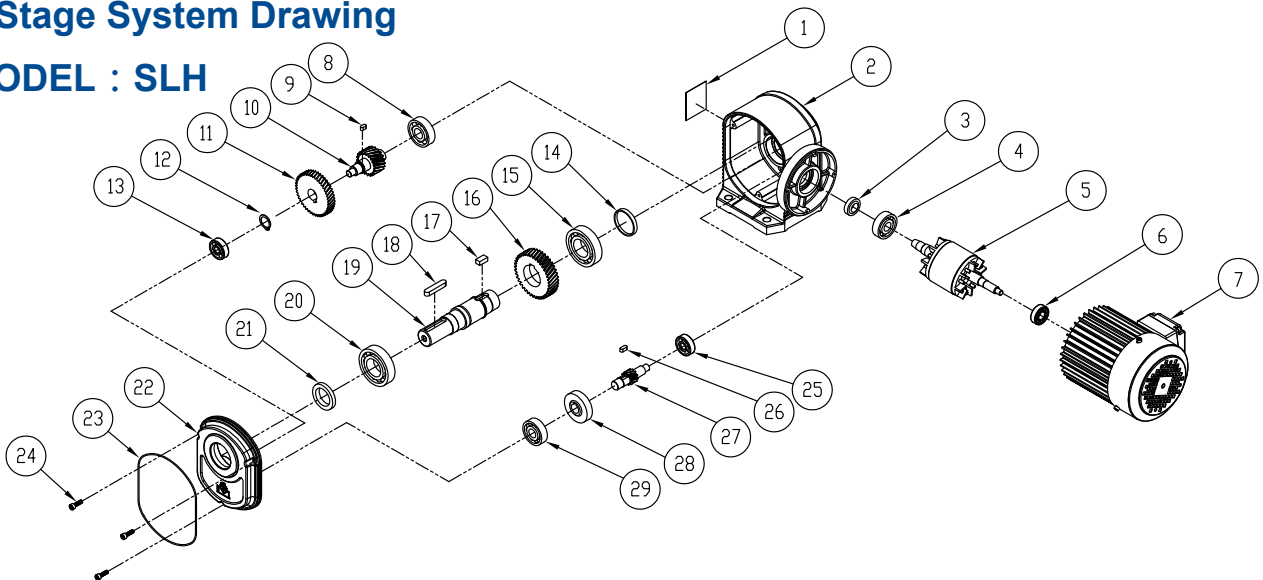

NO.	零件名稱	Name of Parts
1	銘牌	Name Plate
2	本體	Body
3	油封	Oil Seal
4	軸承	Bearing
5	A 齒輪	Gear A
6	軸承	Bearing
7	馬達	Motor
8	軸承	Bearing
9	鍵	Key
10	C 齒輪	Gear C

NO.	零件名稱	Name of Parts
11	F 齒輪	Gear F
12	扣環	Snap Ring
13	軸承	Bearing
14	油封	Oil Seal
15	軸承	Bearing
16	D 齒輪	Gear D
17	鍵	Key
18	鍵	Key
19	出力軸	Output Shaft
20	軸承	Bearing

NO.	零件名稱	Name of Parts
21	油封	Oil Seal
22	本體蓋	Body Cover
23	O 型環	O-Ring
24	固定螺絲	Fixing Screw
25	軸承	Bearing
26	鍵	Key
27	E 齒輪	Gear E
28	B 齒輪	Gear B
29	軸承	Bearing

■ 二段式分解系統圖 2-Stage System Drawing

■ MODEL : SLF

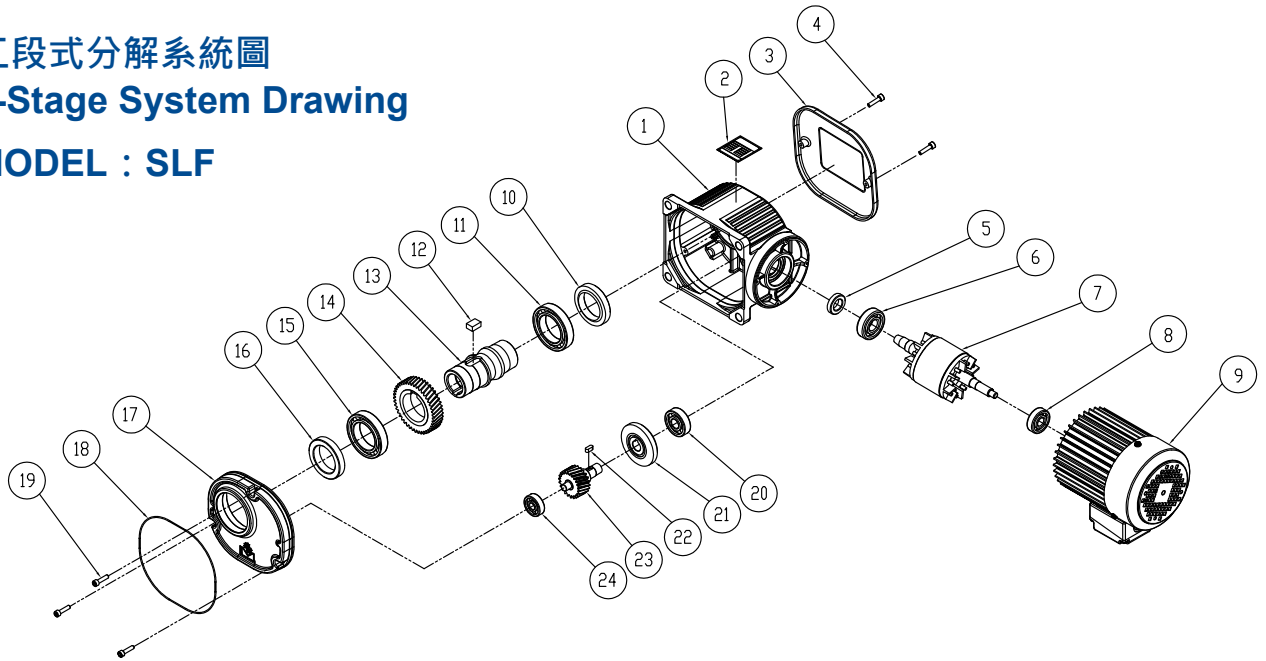

NO.	零件名稱	Name of Parts
1	本體	Body
2	銘牌	Name Plate
3	防護蓋	Protective Cover
4	固定螺絲	Fixing Screw
5	油封	Oil Seal
6	軸承	Bearing
7	A 齒輪	Gear A
8	軸承	Bearing

NO.	零件名稱	Name of Parts
9	馬達	Motor
10	油封	Oil Seal
11	軸承	Bearing
12	鍵	Key
13	出力軸	Output Shaft
14	D 齒輪	Gear D
15	軸承	Bearing
16	油封	Oil Seal

NO.	零件名稱	Name of Parts
17	本體蓋	Body Cover
18	O 型環	O-Ring
19	固定螺絲	Fixing Screw
20	軸承	Bearing
21	B 齒輪	Gear B
22	鍵	Key
23	C 齒輪	Gear C
24	軸承	Bearing

■ 三段式分解系統圖 3-Stage System Drawing

■ MODEL : SLF

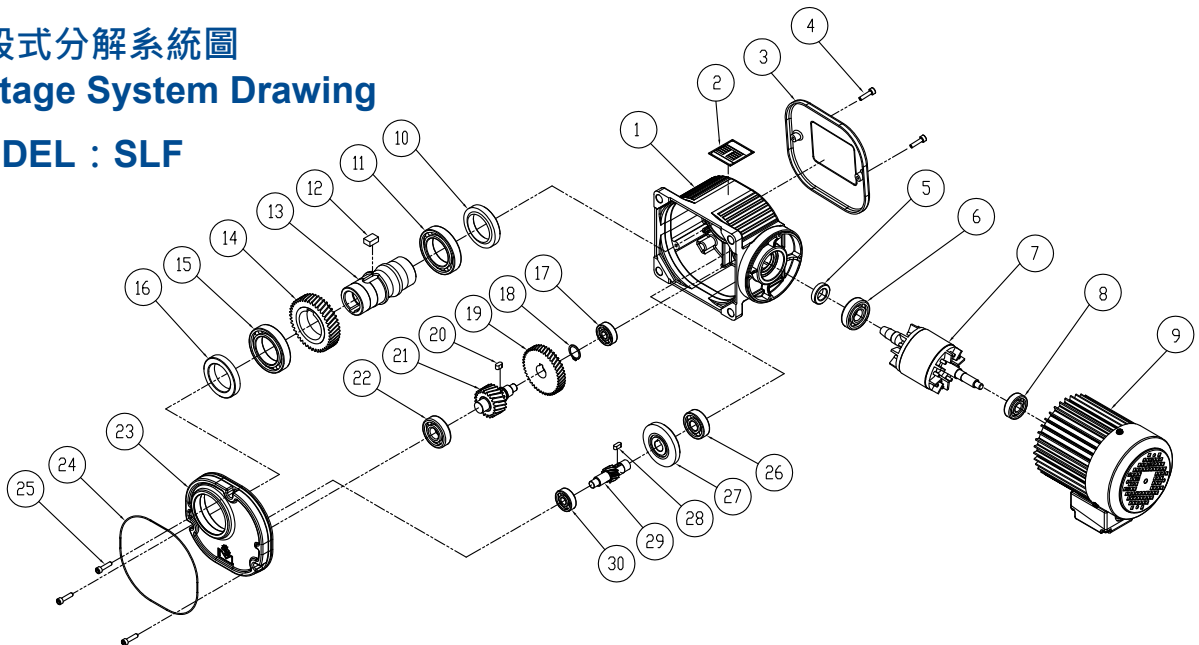

NO.	零件名稱	Name of Parts
1	本體	Body
2	銘牌	Name Plate
3	防護蓋	Protective Cover
4	固定螺絲	Fixing Screw
5	油封	Oil Seal
6	軸承	Bearing
7	A 齒輪	Gear A
8	軸承	Bearing
9	馬達	Motor
10	油封	Oil Seal

NO.	零件名稱	Name of Parts
11	軸承	Bearing
12	鍵	Key
13	出力軸	Output Shaft
14	D 齒輪	Gear D
15	軸承	Bearing
16	油封	Oil Seal
17	軸承	Bearing
18	扣環	Snap Ring
19	F 齒輪	Gear F
20	鍵	Key

NO.	零件名稱	Name of Parts
21	C 齒輪	Gear C
22	軸承	Bearing
23	本體蓋	Body Cover
24	O 型環	O-Ring
25	固定螺絲	Fixing Screw
26	軸承	Bearing
27	B 齒輪	Gear B
28	鍵	Key
29	E 齒輪	Gear E
30	軸承	Bearing

■ 臥式戟齒減速機 Horizontal Type Hypoid Gear Reducer

■ MODEL : SLH

SLH

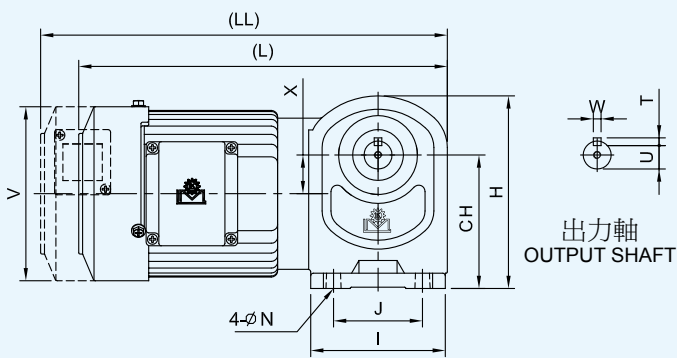

出力軸螺絲孔 Output Shaft Screw Hole	
型號 Model	螺絲規格 Screw Specifications
09	M6
10	M6
11	M8
12	M10
13	M12
14	M16

注：SL 系列通用。
NOTE: Common for SL series.

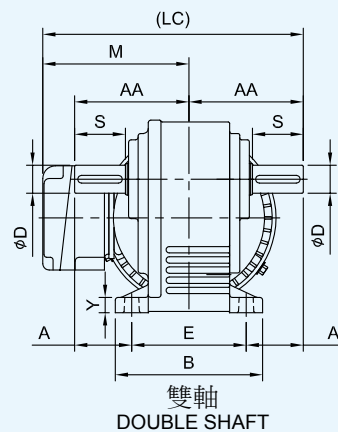
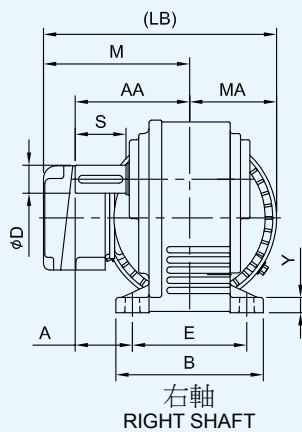
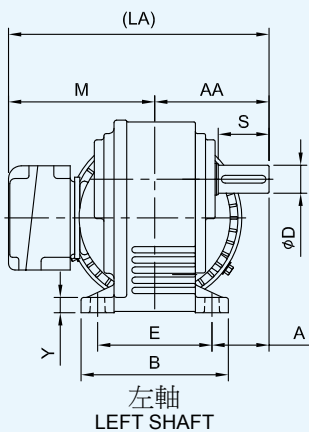

SMALL GEAR REDUCER SERIES



台灣專利字號：M480208
Patent Number(Taiwan)

中國專利字號：201420161664.1
Patent Number(China)

Hypoid Gear

型號 Model	螺絲規格 Screw Specifications
09	M8
10	M8
11	M8
12	M10
13	M12
14	M16

注：此表為尺寸(N) 使用螺絲規格。
NOTE: This table is the size (N) using screw specifications.

unit: mm

馬力 Horse Power	型號 Model	減速比 Ratio	A	AA	J	I	E	B	CH	H	Y	X	N	V	M
60W	09	1/5~1/230(1/250~1/290)	36	81	60	96	90	110	90	138	10	31	9	98	101
90W	09	1/5~1/120(1/155~1/290)	36	81	60	96	90	110	90	138	10	31	9	98	101
1/8HP (0.1kW)	10	1/5~1/200(1/230~1/260)	45	90	70	106	90	116	105	152	12	30	11	137	115
1/4HP (0.2kW)	10	1/5~1/100(1/120~1/260)	45	90	70	106	90	116	105	152	12	30	11	137	115
	11	1/5~1/200(1/225~1/250)	50	100	80	127	100	126	120	177	15	41	11	137	115
1/2HP (0.4kW)	11	1/5~1/100(1/120~1/250)	50	100	80	127	100	126	120	177	15	41	11	137	115
	12	1/5~1/200(1/225~1/250)	60	120	95	154	120	150	140	208	18	47	13	163	131
1HP (0.75kW)	12	1/5~1/100(1/120~1/250)	60	120	95	154	120	150	140	208	18	47	13	163	131
	13	1/5~1/200(1/240)	70	140	120	180	140	180	165	251	20	59	15	181	142
2HP (1.5kW)	13	1/5~1/100(1/125~1/240)	70	140	120	180	140	180	165	251	20	59	15	181	142
	14	1/5~1/160(1/185~1/250)	75	165	150	210	180	230	200	310	25	68	18	181	142
3HP (2.2kW)	14	1/5~1/120(1/160~1/250)	75	165	150	210	180	230	200	310	25	68	18	181	142

unit: mm

馬力 Horse Power	型號 Model	減速比 Ratio	MA	L	LL	LA	LB	LC	出力軸 Output Shaft					重量 Weight (KG)
									D	S	W	T	U	
60W	09	1/5~1/230(1/250~1/290)	49	275	290	182	150	182	18	30	6	6	14.5	
90W	09	1/5~1/120(1/155~1/290)	49	290	305	182	150	182	18	30	6	6	14.5	
1/8HP (0.1kW)	10	1/5~1/200(1/230~1/260)	69	295	315	205	184	205	22	40	6	6	18.5	
1/4HP (0.2kW)	10	1/5~1/100(1/120~1/260)	69	315	335	205	184	205	22	40	6	6	18.5	
	11	1/5~1/200(1/225~1/250)	69	330	350	215	184	215	28	45	8	7	24	
1/2HP (0.4kW)	11	1/5~1/100(1/120~1/250)	69	345	365	215	184	215	28	45	8	7	24	
	12	1/5~1/200(1/225~1/250)	82	345	360	251	213	251	32	55	10	8	27	
1HP (0.75kW)	12	1/5~1/100(1/120~1/250)	82	380	395	251	213	251	32	55	10	8	27	
	13	1/5~1/200(1/240)	91	420	440	282	233	282	40	65	12	8	35	
2HP (1.5kW)	13	1/5~1/100(1/125~1/240)	91	450	470	282	233	282	40	65	12	8	35	
	14	1/5~1/160(1/185~1/250)	91	490	510	307	256	330	50	75	14	9	44.5	
3HP (2.2kW)	14	1/5~1/120(1/160~1/250)	91	530	550	307	256	330	50	75	14	9	44.5	

注：

1. 表中 () 內數字系表示輕荷重使用。
2. 表中重量以配合三相 4P 馬達為主，其它單相、剎車、直流、特殊等馬達重量另訂。
3. 表中 L 內數字以三相馬達為主，其它特殊馬達另訂。
4. 如需特殊馬達規格，請洽本司業務。
5. SLF-O、SLF-D 機種皆適用以上規則。
6. 以上數值若有變更，恕不另行通知。

NOTE：

- 1.Values shown in paranthesis () are used for light loading.
- 2.Weights shown in the above chart are based on 3-phase 4P motors, weights for single phase, brake, DC, or special motor shall be referred to specific values.
- 3.Values shown in 'L' column are based on 3-phase motor, other special motor Refer to specific motor refet to specific values.
- 4.For special motor specifications, please contact our business.
- 5.The above rules apply to both SLF-O and SLF-D models.
- 6.Above specifications are subject to change without prior notice.

■ 法蘭式戟齒減速機
Flange Type Hypoid Gear Reducer

■ MODEL : SLF-O

SLF-O

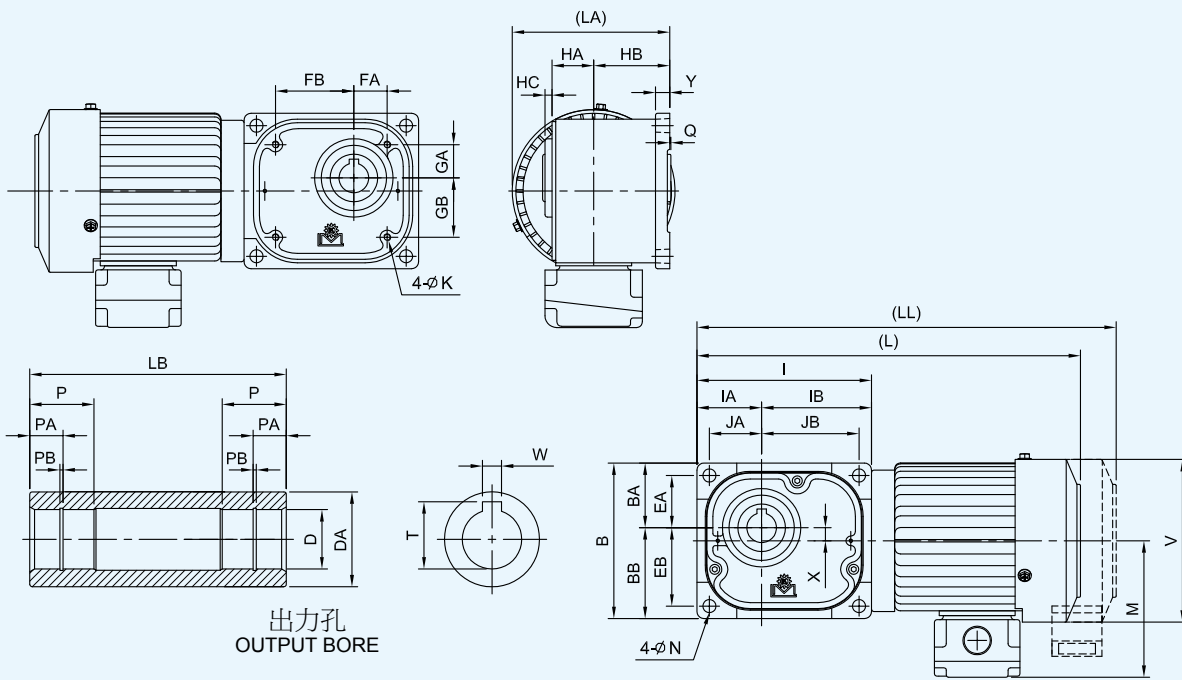

SMALL GEAR REDUCER SERIES



Hypoid Gear

台灣專利字號：M480207
Patent Number(Taiwan)

中國專利字號：201420157782.5
Patent Number(China)

型號 Model	螺絲規格 Screw Specifications
09	M8
10	M8
11	M8
12	M10
13	M12
14	M16

注：此表為尺寸(N) 使用螺絲規格。
NOTE: This table is the size (N) using screw specifications.

unit: mm

馬力 Horse Power	型號 Model	減速比 Ratio	JA	JB	I	IA	IB	EA	EB	B	BA	BB	FA	FB
60W	09	1/5~1/230(1/250~1/290)	38	72	128	47	81	38	56	112	47	65	25	59
90W	09	1/5~1/120(1/155~1/290)	38	72	128	47	81	38	56	112	47	65	25	59
1/8HP (0.1kW)	10	1/5~1/200(1/240)	44	82	147	55	93	44	66	131	55	77	28	66
1/4HP (0.2kW)	10	1/5~1/100(1/120~1/240)	44	82	147	55	93	44	66	131	55	77	28	66
	11	1/5~1/210(1/260)	50	90	164	62	102	50	72	146	62	84	33	73
1/2HP (0.4kW)	11	1/5~1/100(1/120~1/260)	50	90	164	62	102	50	72	146	62	84	33	73
	12	1/5~1/200(1/225~1/250)	56	108	188	68	120	56	88	170	69	101	38	90
1HP (0.75kW)	12	1/5~1/100(1/120~1/250)	56	108	188	68	120	56	88	170	69	101	38	90
	13	1/5~1/200(1/240~1/260)	70	134	234	85	149	70	104	204	85	119	48	112
2HP (1.5kW)	13	1/5~1/100(1/125~1/260)	70	134	234	85	149	70	104	204	85	119	48	112
	14	1/5~1/160(1/180~1/285)	90	168	298	110	188	90	132	262	110	152	58	136
3HP (2.2kW)	14	1/5~1/120(1/160~1/285)	90	168	298	110	188	90	132	262	110	152	58	136

unit: mm

馬力 Horse Power	型號 Model	減速比 Ratio	GA	GB	HA	HB	HC	Q	Y	X	V	M	L	LL
60W	09	1/5~1/230(1/250~1/290)	25	43	29	51	8	1	10	9	98	101	300	315
90W	09	1/5~1/120(1/155~1/290)	25	43	29	51	8	1	10	9	98	101	315	330
1/8HP (0.1kW)	10	1/5~1/200(1/240)	28	50	35	64	6	1	12	11	137	115	330	350
1/4HP (0.2kW)	10	1/5~1/100(1/120~1/240)	28	50	35	64	6	1	12	11	137	115	350	370
	11	1/5~1/210(1/260)	33	55	42	65	7	1	14	11	137	115	365	385
1/2HP (0.4kW)	11	1/5~1/100(1/120~1/260)	33	55	42	65	7	1	14	11	137	115	380	400
	12	1/5~1/200(1/225~1/250)	38	70	44	70	7	1	16	16	151	120	395	400
1HP (0.75kW)	12	1/5~1/100(1/120~1/250)	38	70	44	70	7	1	16	16	151	120	420	425
	13	1/5~1/200(1/240~1/260)	48	82	51	80	6	1	18	17	163	131	460	470
2HP (1.5kW)	13	1/5~1/100(1/125~1/260)	48	82	51	80	6	1	18	17	163	131	480	490
	14	1/5~1/160(1/180~1/285)	58	100	71	98	9	1	22	21	181	142	565	585
3HP (2.2kW)	14	1/5~1/120(1/160~1/285)	58	100	71	98	9	1	22	21	181	142	605	625

unit: mm

馬力 Horse Power	型號 Model	減速比 Ratio	LA	K	N	出力孔 Output Bore							重量 Weight (KG)
						D	DA	W	T	P	PA	PB	
60W	09	1/5~1/230(1/250~1/290)	107	M5	9	20	30	6	22.8	24	13	1.15	91
90W	09	1/5~1/120(1/155~1/290)	107	M5	9	20	30	6	22.8	24	13	1.15	91
1/8HP (0.1kW)	10	1/5~1/200(1/240)	133	M6	11	25	40	8	28.3	30	14	1.35	108
1/4HP (0.2kW)	10	1/5~1/100(1/120~1/240)	133	M6	11	25	40	8	28.3	30	14	1.35	108
	11	1/5~1/210(1/260)	134	M8	11	30	45	8	33.3	35	17	1.35	117
1/2HP (0.4kW)	11	1/5~1/100(1/120~1/260)	134	M8	11	30	45	8	33.3	35	17	1.35	117
	12	1/5~1/200(1/225~1/250)	146	M8	13	35	50	10	38.3	40	20	1.75	124
1HP (0.75kW)	12	1/5~1/100(1/120~1/250)	146	M8	13	35	50	10	38.3	40	20	1.75	124
	13	1/5~1/200(1/240~1/260)	162	M10	15	45	65	14	48.8	50	26	1.95	140
2HP (1.5kW)	13	1/5~1/100(1/125~1/260)	162	M10	15	45	65	14	48.8	50	26	1.95	140
	14	1/5~1/160(1/180~1/285)	189	M12	18	55	80	16	59.3	60	32	2.2	181
3HP (2.2kW)	14	1/5~1/120(1/160~1/285)	189	M12	18	55	80	16	59.3	60	32	2.2	181

注：請參照 SLH 標註內容

NOTE: Please refer to the note for SLH.

■ 法蘭式戟齒減速機
Flange Type Hypoid Gear Reducer

■ MODEL : SLF-D

SLF-D

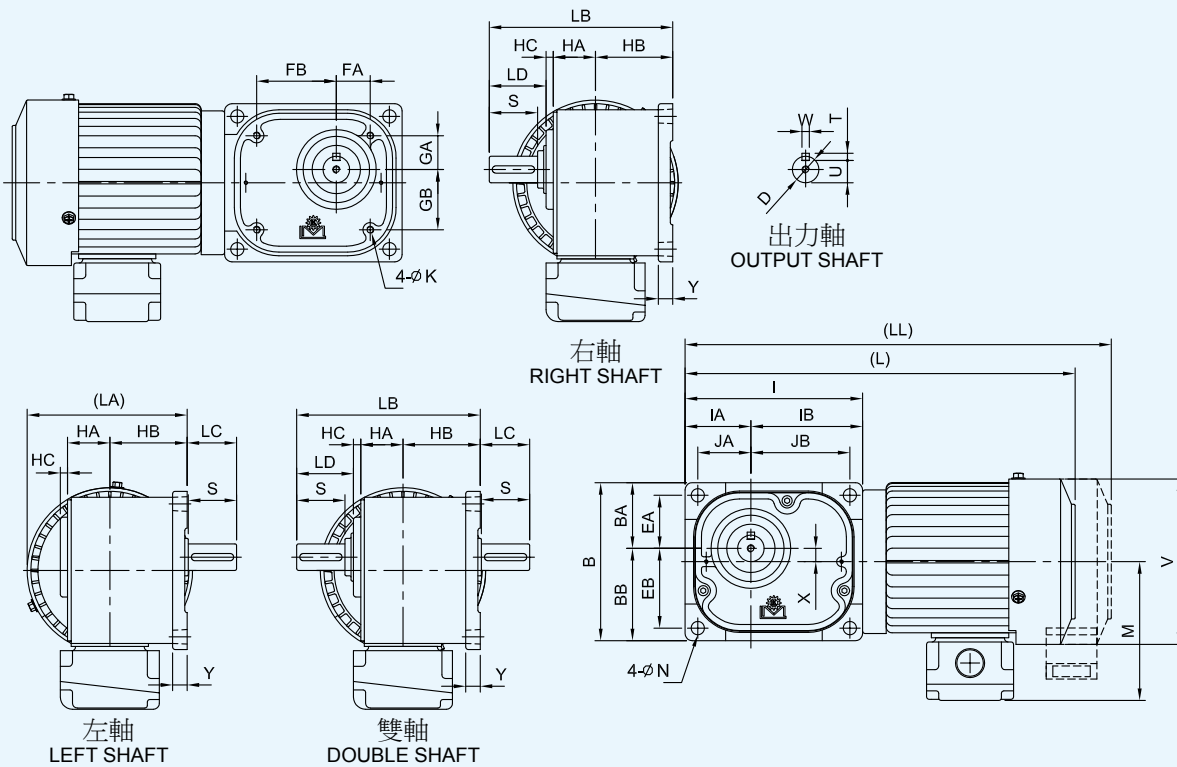

SMALL GEAR REDUCER SERIES



Hypoid Gear

型號 Model	螺絲規格 Screw Specifications
09	M8
10	M8
11	M8
12	M10
13	M12
14	M16

注：此表為尺寸(N) 使用螺絲規格。
NOTE: This table is the size (N) using screw specifications.

unit: mm

馬力 Horse Power	型號 Model	減速比 Ratio	JA	JB	I	IA	IB	EA	EB	B	BA	BB	FA	FB
60W	09	1/5~1/230(1/250~1/290)	38	72	128	47	81	38	56	112	47	65	25	59
90W	09	1/5~1/120(1/155~1/290)	38	72	128	47	81	38	56	112	47	65	25	59
1/8HP (0.1kW)	10	1/5~1/200(1/240)	44	82	147	55	93	44	66	131	55	77	28	66
1/4HP (0.2kW)	10	1/5~1/100(1/120~1/240)	44	82	147	55	93	44	66	131	55	77	28	66
	11	1/5~1/210(1/260)	50	90	164	62	102	50	72	146	62	84	33	73
1/2HP (0.4kW)	11	1/5~1/100(1/120~1/260)	50	90	164	62	102	50	72	146	62	84	33	73
	12	1/5~1/200(1/225~1/250)	56	108	188	68	120	56	88	170	69	101	38	90
1HP (0.75kW)	12	1/5~1/100(1/120~1/250)	56	108	188	68	120	56	88	170	69	101	38	90
	13	1/5~1/200(1/240~1/260)	70	134	234	85	149	70	104	204	85	119	48	112
2HP (1.5kW)	13	1/5~1/100(1/125~1/260)	70	134	234	85	149	70	104	204	85	119	48	112
	14	1/5~1/160(1/180~1/285)	90	168	298	110	188	90	132	262	110	152	58	136
3HP (2.2kW)	14	1/5~1/120(1/160~1/285)	90	168	298	110	188	90	132	262	110	152	58	136

unit: mm

馬力 Horse Power	型號 Model	減速比 Ratio	GA	GB	HA	HB	HC	Y	X	V	M	L	LL	LA
60W	09	1/5~1/230(1/250~1/290)	25	43	29	51	8	10	9	98	101	300	315	107
90W	09	1/5~1/120(1/155~1/290)	25	43	29	51	8	10	9	98	101	315	330	107
1/8HP (0.1kW)	10	1/5~1/200(1/240)	28	50	35	64	6	12	11	137	115	330	350	133
1/4HP (0.2kW)	10	1/5~1/100(1/120~1/240)	28	50	35	64	6	12	11	137	115	350	370	133
	11	1/5~1/210(1/260)	33	55	42	65	7	14	11	137	115	365	385	134
1/2HP (0.4kW)	11	1/5~1/100(1/120~1/260)	33	55	42	65	7	14	11	137	115	380	400	134
	12	1/5~1/200(1/225~1/250)	38	70	44	70	7	16	16	151	120	395	400	146
1HP (0.75kW)	12	1/5~1/100(1/120~1/250)	38	70	44	70	7	16	16	151	120	420	425	146
	13	1/5~1/200(1/240~1/260)	48	82	51	80	6	18	17	163	131	460	470	162
2HP (1.5kW)	13	1/5~1/100(1/125~1/260)	48	82	51	80	6	18	17	163	131	480	490	162
	14	1/5~1/160(1/180~1/285)	58	100	71	98	9	22	21	181	142	565	585	189
3HP (2.2kW)	14	1/5~1/120(1/160~1/285)	58	100	71	98	9	22	21	181	142	605	625	189

unit: mm

馬力 Horse Power	型號 Model	減速比 Ratio	K	N	出力軸 Output Shaft								重量 Weight (KG)
					D	S	W	T	U	LB	LC	LD	
60W	09	1/5~1/230(1/250~1/290)	M5	9	18	30	6	6	14.5	123	34	35	
90W	09	1/5~1/120(1/155~1/290)	M5	9	18	30	6	6	14.5	123	34	35	
1/8HP (0.1kW)	10	1/5~1/200(1/240)	M6	11	22	40	6	6	18.5	152	41	47	
1/4HP (0.2kW)	10	1/5~1/100(1/120~1/240)	M6	11	22	40	6	6	18.5	152	41	47	
	11	1/5~1/210(1/260)	M8	11	28	45	8	7	24	166	50	52	
1/2HP (0.4kW)	11	1/5~1/100(1/120~1/260)	M8	11	28	45	8	7	24	166	50	52	
	12	1/5~1/200(1/225~1/250)	M8	13	32	55	10	8	27	183	61	62	
1HP (0.75kW)	12	1/5~1/100(1/120~1/250)	M8	13	32	55	10	8	27	183	61	62	
	13	1/5~1/200(1/240~1/260)	M10	15	40	65	12	8	35	209	71	72	
2HP (1.5kW)	13	1/5~1/100(1/125~1/260)	M10	15	40	65	12	8	35	209	71	72	
	14	1/5~1/160(1/180~1/285)	M12	18	50	75	14	9	44.5	260	81	82	
3HP (2.2kW)	14	1/5~1/120(1/160~1/285)	M12	18	50	75	14	9	44.5	260	81	82	

注：請參照 SLH 標註內容

NOTE: Please refer to the note for SLH.

■ 臥式馬達自裝式戟齒減速機

Horizontal Motor-Driver Hypoid Gear Reducer

■ MODEL : SLHB

SLHB

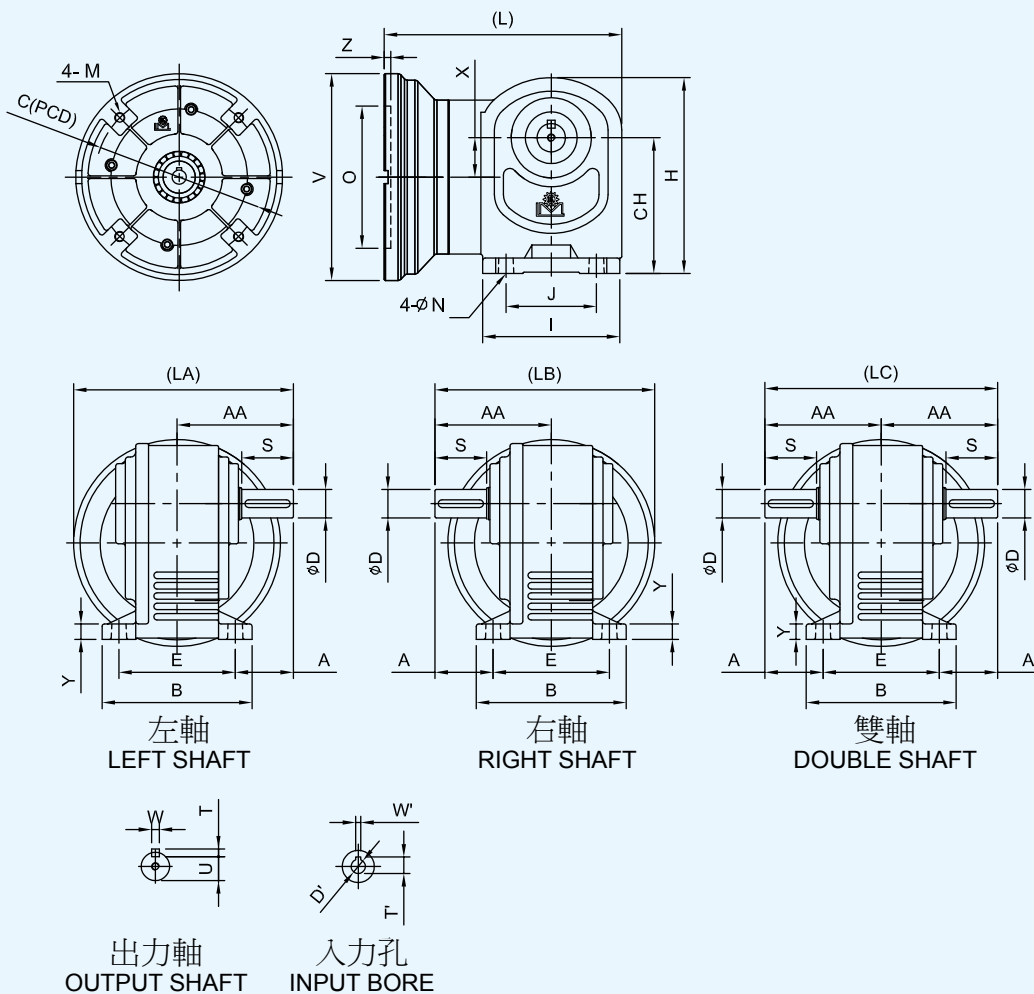

SMALL GEAR REDUCER SERIES



Hypoid Gear

型號 Model	螺絲規格 Screw Specifications
10	M8
11	M8
12	M10
13	M12
14	M16

注：此表為尺寸 (N) 使用螺絲規格。
NOTE: This table is the size (N) using screw specifications.

unit: mm

	馬力 Horse Power	V	O	Z	M	C	D'	W'	T'
入力孔 Input Bore	1/8	160	110	5	M8	130	11	4	12.8
	1/4	160	110	5	M8	130	11	4	12.8
	1/2	160	110	5	M8	130	14	5	16.3
	1	200	130	5	M10	165	19	6	21.8
	2	200	130	5	M10	165	24	8	27.3
	3	250	180	5	M12	215	28	8	31.3

unit: mm

馬力 Horse Power	型號 Model	減速比 Ratio	A	AA	J	I	E	B	CH	H	Y	N	X	L
1/8HP (0.1kW)	10	1/5~1/200(1/230~1/260)	45	90	70	106	90	116	105	152	12	11	30	184
1/4HP (0.2kW)	10	1/5~1/100(1/120~1/260)	45	90	70	106	90	116	105	152	12	11	30	184
	11	1/5~1/200(1/225~1/250)	50	100	80	127	100	126	120	177	15	11	41	198
1/2HP (0.4kW)	11	1/5~1/100(1/120~1/250)	50	100	80	127	100	126	120	177	15	11	41	198
	12	1/5~1/200(1/225~1/250)	60	120	95	154	120	150	140	208	18	13	47	227
1HP (0.75kW)	12	1/5~1/100(1/120~1/250)	60	120	95	154	120	150	140	208	18	13	47	240
	13	1/5~1/200(1/240)	70	140	120	180	140	180	165	251	20	15	59	272
2HP (1.5kW)	13	1/5~1/100(1/125~1/240)	70	140	120	180	140	180	165	251	20	15	59	282
	14	1/5~1/160(1/185~1/250)	75	165	150	210	180	230	200	310	25	18	68	327
3HP (2.2kW)	14	1/5~1/120(1/160~1/250)	75	165	150	210	180	230	200	310	25	18	68	336

unit: mm

馬力 Horse Power	型號 Model	減速比 Ratio	LA	LB	LC	出力軸 Output Shaft					重量 Weight (KG)
						D	S	W	T	U	
1/8HP (0.1kW)	10	1/5~1/200(1/230~1/260)	170	170	180	22	40	6	6	18.5	
1/4HP (0.2kW)	10	1/5~1/100(1/120~1/260)	170	170	180	22	40	6	6	18.5	
	11	1/5~1/200(1/225~1/250)	180	180	200	28	45	8	7	24	
1/2HP (0.4kW)	11	1/5~1/100(1/120~1/250)	180	180	200	28	45	8	7	24	
	12	1/5~1/200(1/225~1/250)	200	200	240	32	55	10	8	27	
1HP (0.75kW)	12	1/5~1/100(1/120~1/250)	220	220	240	32	55	10	8	27	
	13	1/5~1/200(1/240)	240	240	280	40	65	12	8	35	
2HP (1.5kW)	13	1/5~1/100(1/125~1/240)	240	240	280	40	65	12	8	35	
	14	1/5~1/160(1/185~1/250)	265	265	330	50	75	14	9	44.5	
3HP (2.2kW)	14	1/5~1/120(1/160~1/250)	290	290	330	50	75	14	9	44.5	

■ 法蘭式馬達自裝式戟齒減速機
Flange Motor-Driver Hypoid Gear Reducer

■ MODEL : SLFB-O

SLFB-O

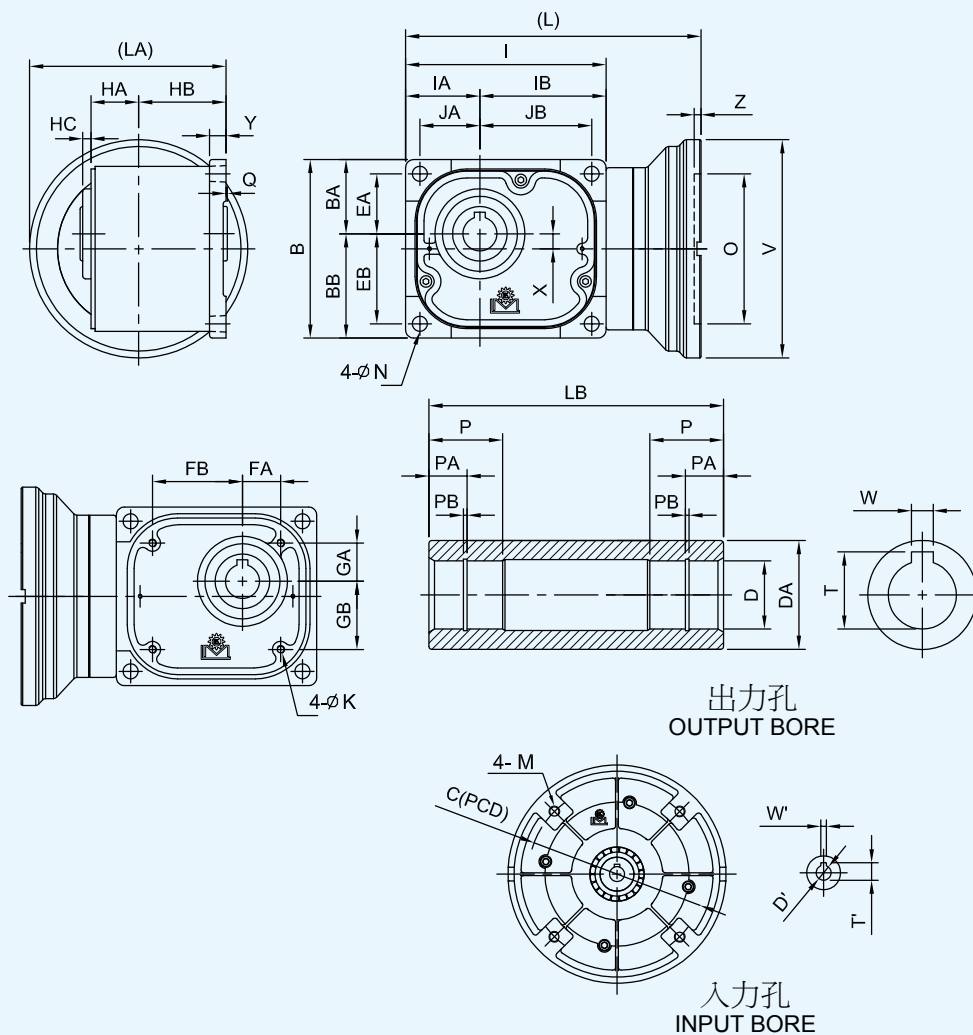

SMALL GEAR REDUCER SERIES



Hypoid Gear

unit: mm

馬力 Horse Power	V	O	Z	M	C	D'	W'	T'	
入力孔 Input Bore	1/8	160	110	5	M8	130	11	4	12.8
	1/4	160	110	5	M8	130	11	4	12.8
	1/2	160	110	5	M8	130	14	5	16.3
	1	200	130	5	M10	165	19	6	21.8
	2	200	130	5	M10	165	24	8	27.3
	3	250	180	5	M12	215	28	8	31.3

型號 Model	螺絲規格 Screw Specifications
10	M8
11	M8
12	M10
13	M12
14	M16

注：此表為尺寸 (N) 使用螺絲規格。
NOTE: This table is the size (N) using screw specifications.

unit: mm

馬力 Horse Power	型號 Model	減速比 Ratio	JA	JB	I	IA	IB	EA	EB	B	BA	BB	FA	FB
1/8HP (0.1kW)	10	1/5~1/200(1/240)	44	82	147	55	93	44	66	131	55	77	28	66
1/4HP (0.2kW)	10	1/5~1/100(1/120~1/240)	44	82	147	55	93	44	66	131	55	77	28	66
	11	1/5~1/210(1/260)	50	90	164	62	102	50	72	146	62	84	33	73
1/2HP (0.4kW)	11	1/5~1/100(1/120~1/260)	50	90	164	62	102	50	72	146	62	84	33	73
	12	1/5~1/200(1/225~1/250)	56	108	188	68	120	56	88	170	69	101	38	90
1HP (0.75kW)	12	1/5~1/100(1/120~1/250)	56	108	188	68	120	56	88	170	69	101	38	90
	13	1/5~1/200(1/240~1/260)	70	134	234	85	149	70	104	204	85	119	48	112
2HP (1.5kW)	13	1/5~1/100(1/125~1/260)	70	134	234	85	149	70	104	204	85	119	48	112
	14	1/5~1/160(1/180~1/285)	90	168	298	110	188	90	132	262	110	152	58	136
3HP (2.2kW)	14	1/5~1/120(1/160~1/285)	90	168	298	110	188	90	132	262	110	152	58	136

unit: mm

馬力 Horse Power	型號 Model	減速比 Ratio	GA	GB	HA	HB	HC	Q	Y	X	L	LA	K	N
1/8HP (0.1kW)	10	1/5~1/200(1/240)	28	50	35	64	6	1	12	11	217	144	M6	11
1/4HP (0.2kW)	10	1/5~1/100(1/120~1/240)	28	50	35	64	6	1	12	11	217	144	M6	11
	11	1/5~1/210(1/260)	33	55	42	65	7	1	14	11	234	145	M8	11
1/2HP (0.4kW)	11	1/5~1/100(1/120~1/260)	33	55	42	65	7	1	14	11	234	145	M8	11
	12	1/5~1/200(1/225~1/250)	38	70	44	70	7	1	16	16	259	150	M8	13
1HP (0.75kW)	12	1/5~1/100(1/120~1/250)	38	70	44	70	7	1	16	16	273	170	M8	13
	13	1/5~1/200(1/240~1/260)	48	82	51	80	6	1	18	17	319	180	M10	15
2HP (1.5kW)	13	1/5~1/100(1/125~1/260)	48	82	51	80	6	1	18	17	329	180	M10	15
	14	1/5~1/160(1/180~1/285)	58	100	71	98	9	1	22	21	401	198	M12	18
3HP (2.2kW)	14	1/5~1/120(1/160~1/285)	58	100	71	98	9	1	22	21	410	223	M12	18

unit: mm

馬力 Horse Power	型號 Model	減速比 Ratio	出力孔 Output Bore								重量 Weight (KG)
			D	DA	W	T	P	PA	PB	LB	
1/8HP (0.1kW)	10	1/5~1/200(1/240)	25	40	8	28.3	30	14	1.35	108	
1/4HP (0.2kW)	10	1/5~1/100(1/120~1/240)	25	40	8	28.3	30	14	1.35	108	
	11	1/5~1/210(1/260)	30	45	8	33.3	35	17	1.35	117	
1/2HP (0.4kW)	11	1/5~1/100(1/120~1/260)	30	45	8	33.3	35	17	1.35	117	
	12	1/5~1/200(1/225~1/250)	35	50	10	38.3	40	20	1.75	124	
1HP (0.75kW)	12	1/5~1/100(1/120~1/250)	35	50	10	38.3	40	20	1.75	124	
	13	1/5~1/200(1/240~1/260)	45	65	14	48.8	50	26	1.95	140	
2HP (1.5kW)	13	1/5~1/100(1/125~1/260)	45	65	14	48.8	50	26	1.95	140	
	14	1/5~1/160(1/180~1/285)	55	80	16	59.3	60	32	2.2	181	
3HP (2.2kW)	14	1/5~1/120(1/160~1/285)	55	80	16	59.3	60	32	2.2	181	

■ 法蘭式馬達自裝式戟齒減速機
Flange Motor-Driver Hypoid Gear Reducer

■ MODEL : SLFB-D

SLFB-D

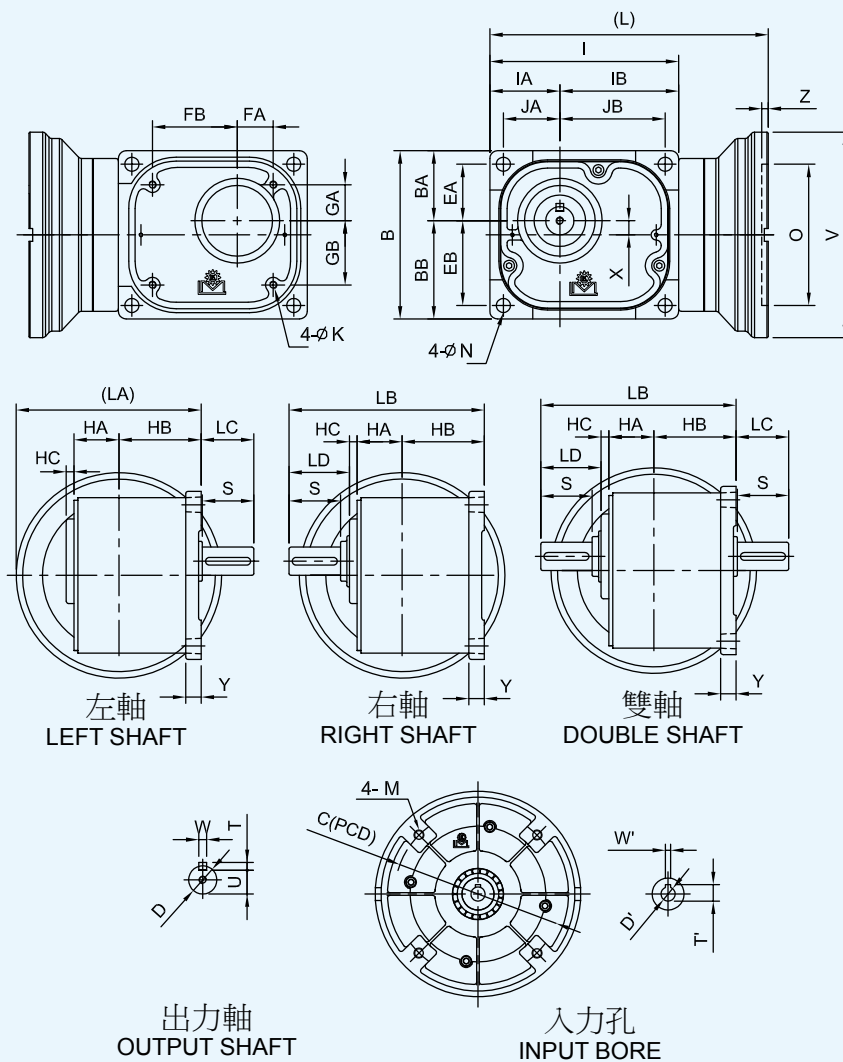

SMALL GEAR REDUCER SERIES

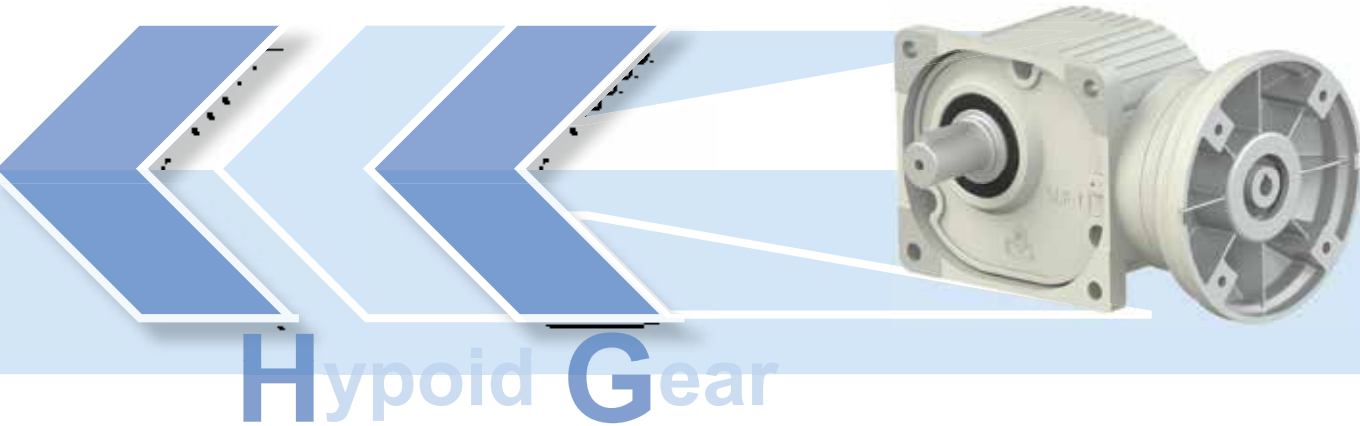

unit: mm

馬力 Horse Power	V	O	Z	M	C	D'	W'	T'	
入力孔 Input Bore	1/8	160	110	5	M8	130	11	4	12.8
	1/4	160	110	5	M8	130	11	4	12.8
	1/2	160	110	5	M8	130	14	5	16.3
	1	200	130	5	M10	165	19	6	21.8
	2	200	130	5	M10	165	24	8	27.3
	3	250	180	5	M12	215	28	8	31.3

型號 Model	螺絲規格 Screw Specifications
10	M8
11	M8
12	M10
13	M12
14	M16

注：此表為尺寸 (N) 使用螺絲規格。
NOTE: This table is the size (N) using screw specifications.

unit: mm

馬力 Horse Power	型號 Model	減速比 Ratio	JA	JB	I	IA	IB	EA	EB	B	BA	BB	FA	FB
1/8HP (0.1kW)	10	1/5~1/200(1/240)	44	82	147	55	93	44	66	131	55	77	28	66
1/4HP (0.2kW)	10	1/5~1/100(1/120~1/240)	44	82	147	55	93	44	66	131	55	77	28	66
	11	1/5~1/210(1/260)	50	90	164	62	102	50	72	146	62	84	33	73
1/2HP (0.4kW)	11	1/5~1/100(1/120~1/260)	50	90	164	62	102	50	72	146	62	84	33	73
	12	1/5~1/200(1/225~1/250)	56	108	188	68	120	56	88	170	69	101	38	90
1HP (0.75kW)	12	1/5~1/100(1/120~1/250)	56	108	188	68	120	56	88	170	69	101	38	90
	13	1/5~1/200(1/240~1/260)	70	134	234	85	149	70	104	204	85	119	48	112
2HP (1.5kW)	13	1/5~1/100(1/125~1/260)	70	134	234	85	149	70	104	204	85	119	48	112
	14	1/5~1/160(1/180~1/285)	90	168	298	110	188	90	132	262	110	152	58	136
3HP (2.2kW)	14	1/5~1/120(1/160~1/285)	90	168	298	110	188	90	132	262	110	152	58	136

unit: mm

馬力 Horse Power	型號 Model	減速比 Ratio	GA	GB	HA	HB	HC	Y	X	L	LA	K	N
1/8HP (0.1kW)	10	1/5~1/200(1/240)	28	50	35	64	6	12	11	217	144	M6	11
1/4HP (0.2kW)	10	1/5~1/100(1/120~1/240)	28	50	35	64	6	12	11	217	144	M6	11
	11	1/5~1/210(1/260)	33	55	42	65	7	14	11	234	145	M8	11
1/2HP (0.4kW)	11	1/5~1/100(1/120~1/260)	33	55	42	65	7	14	11	234	145	M8	11
	12	1/5~1/200(1/225~1/250)	38	70	44	70	7	16	16	259	150	M8	13
1HP (0.75kW)	12	1/5~1/100(1/120~1/250)	38	70	44	70	7	16	16	273	170	M8	13
	13	1/5~1/200(1/240~1/260)	48	82	51	80	6	18	17	319	180	M10	15
2HP (1.5kW)	13	1/5~1/100(1/125~1/260)	48	82	51	80	6	18	17	329	180	M10	15
	14	1/5~1/160(1/180~1/285)	58	100	71	98	9	22	21	401	198	M12	18
3HP (2.2kW)	14	1/5~1/120(1/160~1/285)	58	100	71	98	9	22	21	410	223	M12	18

unit: mm

馬力 Horse Power	型號 Model	減速比 Ratio	輸出軸 Output Shaft								重量 Weight (KG)
			D	S	W	T	U	LB	LC	LD	
1/8HP (0.1kW)	10	1/5~1/200(1/240)	22	40	6	6	18.5	152	41	47	
1/4HP (0.2kW)	10	1/5~1/100(1/120~1/240)	22	40	6	6	18.5	152	41	47	
	11	1/5~1/210(1/260)	28	45	8	7	24	166	50	52	
1/2HP (0.4kW)	11	1/5~1/100(1/120~1/260)	28	45	8	7	24	166	50	52	
	12	1/5~1/200(1/225~1/250)	32	55	10	8	27	183	61	62	
1HP (0.75kW)	12	1/5~1/100(1/120~1/250)	32	55	10	8	27	183	61	62	
	13	1/5~1/200(1/240~1/260)	40	65	12	8	35	209	71	72	
2HP (1.5kW)	13	1/5~1/100(1/125~1/260)	40	65	12	8	35	209	71	72	
	14	1/5~1/160(1/180~1/285)	50	75	14	9	44.5	260	81	82	
3HP (2.2kW)	14	1/5~1/120(1/160~1/285)	50	75	14	9	44.5	260	81	82	

■ 臥式雙軸戟齒減速機

Horizontal Double-Axle Hypoid Gear Reducer

■ MODEL : SLHD

SLHD

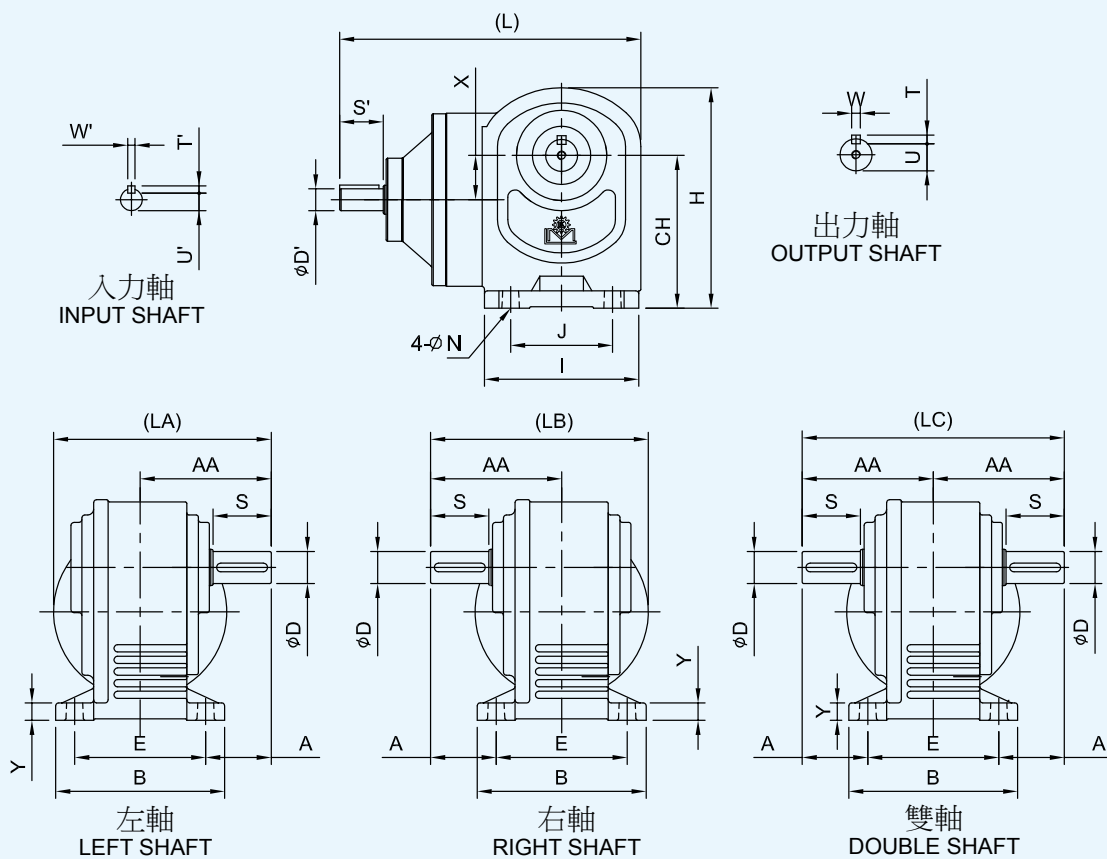

SMALL GEAR REDUCER SERIES



Hypoid Gear

型號 Model	螺絲規格 Screw Specifications
10	M8
11	M8
12	M10
13	M12
14	M16

注：此表為尺寸(N) 使用螺絲規格。
NOTE: This table is the size (N) using screw specifications.

unit: mm

	馬力 Horse Power	D'	S'	W'	T'	U'
入力軸 Input Shaft	1/8	12	25	4	4	9.5
	1/4	12	25	4	4	9.5
	1/2	15	30	5	5	12
	1	20	35	6	6	16.5
	2	25	40	8	7	21
	3	30	45	8	7	26

unit: mm

馬力 Horse Power	型號 Model	減速比 Ratio	A	AA	J	I	E	B	CH	H	Y	N	X	L
1/8HP (0.1kW)	10	1/5~1/200(1/230~1/260)	45	90	70	106	90	116	105	152	12	11	30	202
1/4HP (0.2kW)	10	1/5~1/100(1/120~1/260)	45	90	70	106	90	116	105	152	12	11	30	202
	11	1/5~1/200(1/225~1/250)	50	100	80	127	100	126	120	177	15	11	41	217
1/2HP (0.4kW)	11	1/5~1/100(1/120~1/250)	50	100	80	127	100	126	120	177	15	11	41	222
	12	1/5~1/200(1/225~1/250)	60	120	95	154	120	150	140	208	18	13	47	266
1HP (0.75kW)	12	1/5~1/100(1/120~1/250)	60	120	95	154	120	150	140	208	18	13	47	271
	13	1/5~1/200(1/240)	70	140	120	180	140	180	165	251	20	15	59	308
2HP (1.5kW)	13	1/5~1/100(1/125~1/240)	70	140	120	180	140	180	165	251	20	15	59	317
	14	1/5~1/160(1/185~1/250)	75	165	150	210	180	230	200	310	25	18	68	362
3HP (2.2kW)	14	1/5~1/120(1/160~1/250)	75	165	150	210	180	230	200	310	25	18	68	378

unit: mm

馬力 Horse Power	型號 Model	減速比 Ratio	LA	LB	LC	出力軸 Output Shaft					重量 Weight (KG)
						D	S	W	T	U	
1/8HP (0.1kW)	10	1/5~1/200(1/230~1/260)	150	150	180	22	40	6	6	18.5	
1/4HP (0.2kW)	10	1/5~1/100(1/120~1/260)	150	150	180	22	40	6	6	18.5	
	11	1/5~1/200(1/225~1/250)	160	160	200	28	45	8	7	24	
1/2HP (0.4kW)	11	1/5~1/100(1/120~1/250)	160	160	200	28	45	8	7	24	
	12	1/5~1/200(1/225~1/250)	193	193	240	32	55	10	8	27	
1HP (0.75kW)	12	1/5~1/100(1/120~1/250)	193	193	240	32	55	10	8	27	
	13	1/5~1/200(1/240)	222	222	280	40	65	12	8	35	
2HP (1.5kW)	13	1/5~1/100(1/125~1/240)	222	222	280	40	65	12	8	35	
	14	1/5~1/160(1/185~1/250)	252	252	330	50	75	14	9	44.5	
3HP (2.2kW)	14	1/5~1/120(1/160~1/250)	252	252	330	50	75	14	9	44.5	

■ 法蘭式雙軸戟齒減速機 Flange Double-Axle Hypoid Gear Reducer

■ MODEL : SLFD-O

SLFD-O

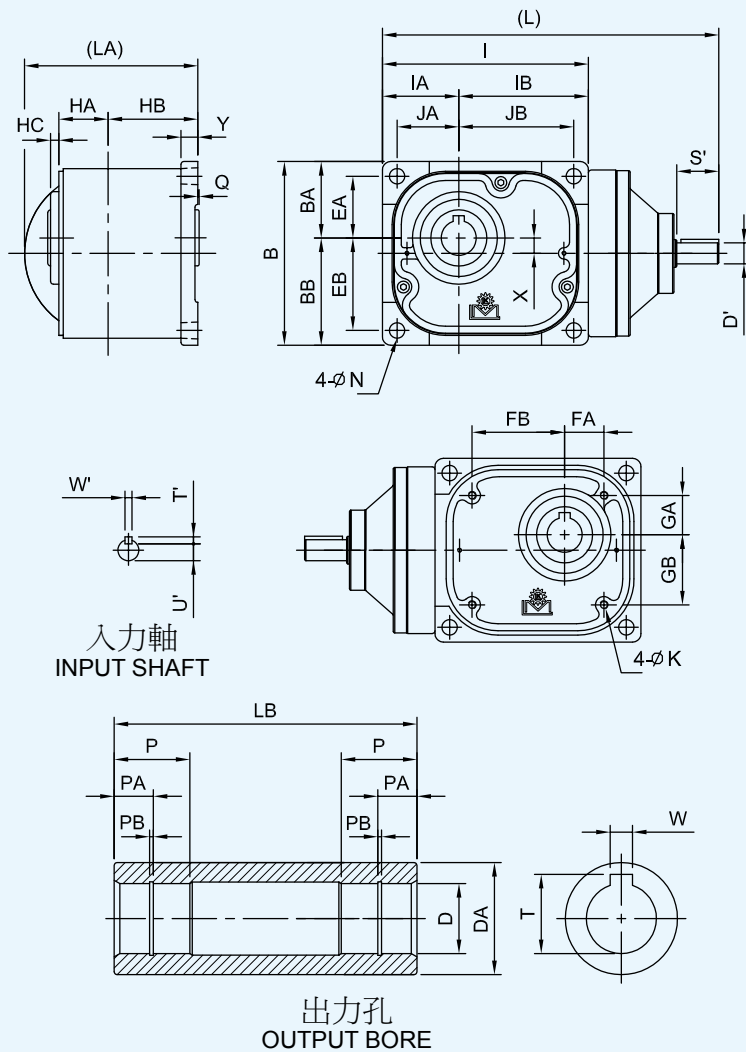

SMALL GEAR REDUCER SERIES



Hypoid Gear

unit: m/m

馬力 Horse Power	D'	S'	W'	T'	U'
1/8	12	25	4	4	9.5
1/4	12	25	4	4	9.5
1/2	15	30	5	5	12
1	20	35	6	6	16.5
2	25	40	8	7	21
3	30	45	8	7	26

型號 Model	螺絲規格 Screw Specifications
10	M8
11	M8
12	M10
13	M12
14	M16

注：此表為尺寸 (N) 使用螺絲規格。
NOTE: This table is the size (N) using screw specifications.

unit: mm

馬力 Horse Power	型號 Model	減速比 Ratio	JA	JB	I	IA	IB	EA	EB	B	BA	BB	FA	FB
1/8HP (0.1kW)	10	1/5~1/200(1/240)	44	82	147	55	93	44	66	131	55	77	28	66
1/4HP (0.2kW)	10	1/5~1/100(1/120~1/240)	44	82	147	55	93	44	66	131	55	77	28	66
	11	1/5~1/210(1/260)	50	90	164	62	102	50	72	146	62	84	33	73
1/2HP (0.4kW)	11	1/5~1/100(1/120~1/260)	50	90	164	62	102	50	72	146	62	84	33	73
	12	1/5~1/200(1/225~1/250)	56	108	188	68	120	56	88	170	69	101	38	90
1HP (0.75kW)	12	1/5~1/100(1/120~1/250)	56	108	188	68	120	56	88	170	69	101	38	90
	13	1/5~1/200(1/240~1/260)	70	134	234	85	149	70	104	204	85	119	48	112
2HP (1.5kW)	13	1/5~1/100(1/125~1/260)	70	134	234	85	149	70	104	204	85	119	48	112
	14	1/5~1/160(1/180~1/285)	90	168	298	110	188	90	132	262	110	152	58	136
3HP (2.2kW)	14	1/5~1/120(1/160~1/285)	90	168	298	110	188	90	132	262	110	152	58	136

unit: mm

馬力 Horse Power	型號 Model	減速比 Ratio	GA	GB	HA	HB	HC	Q	Y	X	L	LA	K	N
1/8HP (0.1kW)	10	1/5~1/200(1/240)	28	50	35	64	6	1	12	11	235	124	M6	11
1/4HP (0.2kW)	10	1/5~1/100(1/120~1/240)	28	50	35	64	6	1	12	11	235	124	M6	11
	11	1/5~1/210(1/260)	33	55	42	65	7	1	14	11	253	125	M8	11
1/2HP (0.4kW)	11	1/5~1/100(1/120~1/260)	33	55	42	65	7	1	14	11	258	125	M8	11
	12	1/5~1/200(1/225~1/250)	38	70	44	70	7	1	16	16	284	135	M8	13
1HP (0.75kW)	12	1/5~1/100(1/120~1/250)	38	70	44	70	7	1	16	16	303	135	M8	13
	13	1/5~1/200(1/240~1/260)	48	82	51	80	6	1	18	17	349	153	M10	15
2HP (1.5kW)	13	1/5~1/100(1/125~1/260)	48	82	51	80	6	1	18	17	364	153	M10	15
	14	1/5~1/160(1/180~1/285)	58	100	71	98	9	1	22	21	436	178	M12	18
3HP (2.2kW)	14	1/5~1/120(1/160~1/285)	58	100	71	98	9	1	22	21	452	178	M12	18

unit: mm

馬力 Horse Power	型號 Model	減速比 Ratio	出力孔 Output Bore								重量 Weight (KG)
			D	DA	W	T	P	PA	PB	LB	
1/8HP (0.1kW)	10	1/5~1/200(1/240)	25	40	8	28.3	30	14	1.35	108	
1/4HP (0.2kW)	10	1/5~1/100(1/120~1/240)	25	40	8	28.3	30	14	1.35	108	
	11	1/5~1/210(1/260)	30	45	8	33.3	35	17	1.35	117	
1/2HP (0.4kW)	11	1/5~1/100(1/120~1/260)	30	45	8	33.3	35	17	1.35	117	
	12	1/5~1/200(1/225~1/250)	35	50	10	38.3	40	20	1.75	124	
1HP (0.75kW)	12	1/5~1/100(1/120~1/250)	35	50	10	38.3	40	20	1.75	124	
	13	1/5~1/200(1/240~1/260)	45	65	14	48.8	50	26	1.95	140	
2HP (1.5kW)	13	1/5~1/100(1/125~1/260)	45	65	14	48.8	50	26	1.95	140	
	14	1/5~1/160(1/180~1/285)	55	80	16	59.3	60	32	2.2	181	
3HP (2.2kW)	14	1/5~1/120(1/160~1/285)	55	80	16	59.3	60	32	2.2	181	

■ 法蘭式雙軸戟齒減速機
Flange Double-Axle Hypoid Gear Reducer

■ MODEL : SLFD-D

SLFD-D

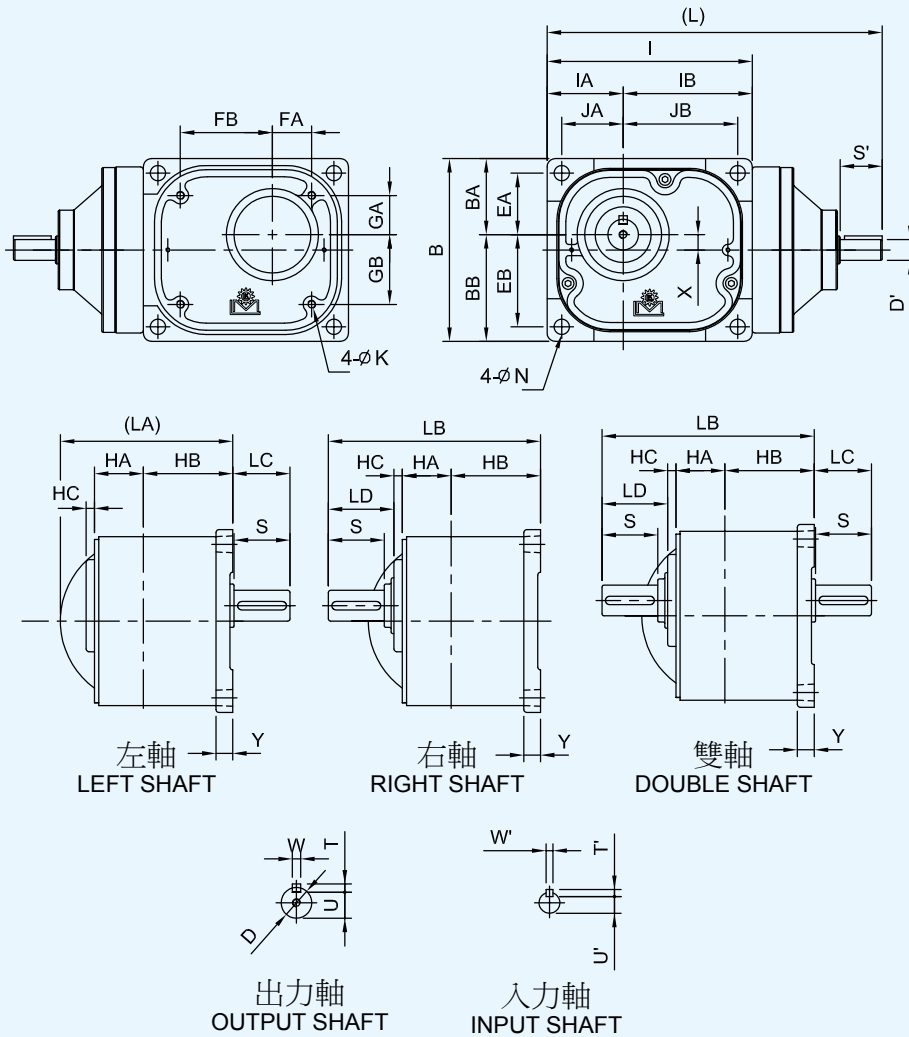

SMALL GEAR REDUCER SERIES



Hypoid Gear

unit: m/m

	馬力 Horse Power	D'	S'	W'	T'	U'
入力軸 Input Shaft	1/8	12	25	4	4	9.5
	1/4	12	25	4	4	9.5
	1/2	15	30	5	5	12
	1	20	35	6	6	16.5
	2	25	40	8	7	21
	3	30	45	8	7	26

型號 Model	螺絲規格 Screw Specifications
10	M8
11	M8
12	M10
13	M12
14	M16

注：此表為尺寸 (N) 使用螺絲規格。
NOTE: This table is the size (N) using screw specifications.

unit: mm

馬力 Horse Power	型號 Model	減速比 Ratio	JA	JB	I	IA	IB	EA	EB	B	BA	BB	FA	FB
1/8HP (0.1kW)	10	1/5~1/200(1/240)	44	82	147	55	93	44	66	131	55	77	28	66
1/4HP (0.2kW)	10	1/5~1/100(1/120~1/240)	44	82	147	55	93	44	66	131	55	77	28	66
	11	1/5~1/210(1/260)	50	90	164	62	102	50	72	146	62	84	33	73
1/2HP (0.4kW)	11	1/5~1/100(1/120~1/260)	50	90	164	62	102	50	72	146	62	84	33	73
	12	1/5~1/200(1/225~1/250)	56	108	188	68	120	56	88	170	69	101	38	90
1HP (0.75kW)	12	1/5~1/100(1/120~1/250)	56	108	188	68	120	56	88	170	69	101	38	90
	13	1/5~1/200(1/240~1/260)	70	134	234	85	149	70	104	204	85	119	48	112
2HP (1.5kW)	13	1/5~1/100(1/125~1/260)	70	134	234	85	149	70	104	204	85	119	48	112
	14	1/5~1/160(1/180~1/285)	90	168	298	110	188	90	132	262	110	152	58	136
3HP (2.2kW)	14	1/5~1/120(1/160~1/285)	90	168	298	110	188	90	132	262	110	152	58	136

unit: mm

馬力 Horse Power	型號 Model	減速比 Ratio	GA	GB	HA	HB	HC	Y	X	L	LA	K	N
1/8HP (0.1kW)	10	1/5~1/200(1/240)	28	50	35	64	6	12	11	235	124	M6	11
1/4HP (0.2kW)	10	1/5~1/100(1/120~1/240)	28	50	35	64	6	12	11	235	124	M6	11
	11	1/5~1/210(1/260)	33	55	42	65	7	14	11	253	125	M8	11
1/2HP (0.4kW)	11	1/5~1/100(1/120~1/260)	33	55	42	65	7	14	11	258	125	M8	11
	12	1/5~1/200(1/225~1/250)	38	70	44	70	7	16	16	284	135	M8	13
1HP (0.75kW)	12	1/5~1/100(1/120~1/250)	38	70	44	70	7	16	16	303	135	M8	13
	13	1/5~1/200(1/240~1/260)	48	82	51	80	6	18	17	349	153	M10	15
2HP (1.5kW)	13	1/5~1/100(1/125~1/260)	48	82	51	80	6	18	17	364	153	M10	15
	14	1/5~1/160(1/180~1/285)	58	100	71	98	9	22	21	436	180	M12	18
3HP (2.2kW)	14	1/5~1/120(1/160~1/285)	58	100	71	98	9	22	21	452	180	M12	18

unit: mm

馬力 Horse Power	型號 Model	減速比 Ratio	出力軸 Output Shaft									重量 Weight (KG)
			D	S	W	T	U	LB	LC	LD		
1/8HP (0.1kW)	10	1/5~1/200(1/240)	22	40	6	6	18.5	152	41	47		
1/4HP (0.2kW)	10	1/5~1/100(1/120~1/240)	22	40	6	6	18.5	152	41	47		
	11	1/5~1/210(1/260)	28	45	8	7	24	166	50	52		
1/2HP (0.4kW)	11	1/5~1/100(1/120~1/260)	28	45	8	7	24	166	50	52		
	12	1/5~1/200(1/225~1/250)	32	55	10	8	27	183	61	62		
1HP (0.75kW)	12	1/5~1/100(1/120~1/250)	32	55	10	8	27	183	61	62		
	13	1/5~1/200(1/240~1/260)	40	65	12	8	35	209	71	72		
2HP (1.5kW)	13	1/5~1/100(1/125~1/260)	40	65	12	8	35	209	71	72		
	14	1/5~1/160(1/180~1/285)	50	75	14	9	44.5	260	81	82		
3HP (2.2kW)	14	1/5~1/120(1/160~1/285)	50	75	14	9	44.5	260	81	82		

■ 臥式多速比戟齒減速機

Horizontal High Reduction Hypoid Gear Reducer

■ MODEL : SLHL

S

LHL



SMALL GEAR REDUCER SERIES

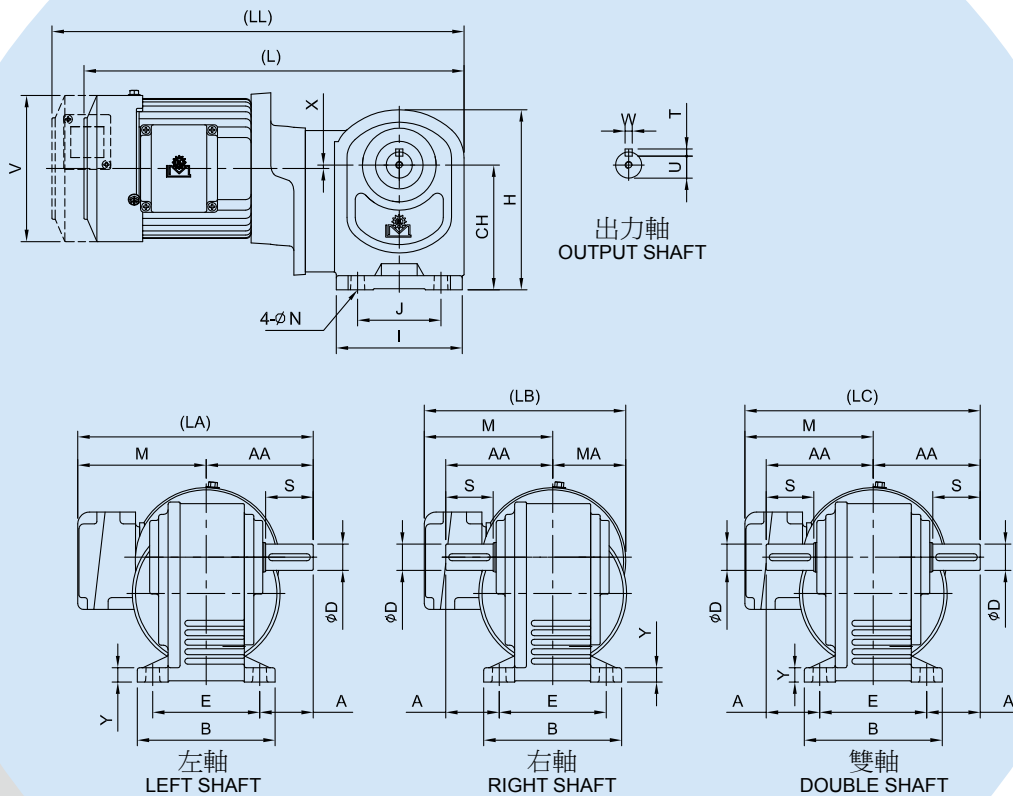

型號 Model	螺絲規格 Screw Specifications
10	M8
11	M8
12	M10
13	M12
14	M16

注：此表為尺寸(N)使用螺絲規格。
NOTE: This table is the size (N) using screw specifications.

最大容許扭力 Max. Permissible Torque					
型號 Model No.	10	11	12	13	14
扭力 Torque kg-m	10	20	40	75	110

馬力 Horse Power	型號 Model	減速比 Ratio	A	AA	J	I	E	B	CH	H	Y	X	N	V	M
1/8HP (0.1kW)	10	1/250~1/2500	45	90	70	106	90	116	105	152	12	3	11	137	115
	11		50	100	80	127	100	126	120	177	15	14.3	11	137	115
1/4HP (0.2kW)	12		60	120	95	154	120	150	140	208	18	13.7	13	137	115
1/2HP (0.4kW)	13		70	140	120	180	140	180	165	251	20	16.9	15	151	120
1HP (0.75kW)	14		75	165	150	210	180	230	200	310	25	15	18	163	132

unit: mm

馬力 Horse Power	型號 Model	減速比 Ratio	MA	L	LL	LA	LB	LC	出力軸 Output Shaft					重量 Weight (KG)
									D	S	W	T	U	
1/8HP (0.1kW)	10	1/250~1/2500	69	340	360	205	183	205	22	40	6	6	18.5	
	11		69	355	375	215	183	215	28	45	8	7	24	
1/4HP (0.2kW)	12		76	415	435	235	196	240	32	55	10	8	27	
1/2HP (0.4kW)	13		85	455	460	260	225	280	40	65	12	8	35	
1HP (0.75kW)	14		87	535	545	297	252	330	50	75	14	9	44.5	

unit: mm

注：

- 表中 () 內數字系表示輕荷重使用。
- 表中重量以配合三相 4P 馬達為主，其它單相、制車、直流、特殊等馬達重量另訂。
- 表中 L 內數字以三相馬達為主，其它特殊馬達另訂。
- 如需特殊馬達規格，請洽本司業務。
- 以上數值若有變更，恕不另行通知。

NOTE :

- Values shown in paranthesis () are used for light loading.
- Weights shown in the above chart are based on 3-phase 4P motors, weights for single phase, brake, DC, or special motor shall be referred to specific values.
- Values shown in 'L' column are based on 3-phase motor, other special motor Refer to specific motor refer to specific values.
- For special motor specifications, please contact our business.
- Above specifications are subject to change without prior notice.

■ 法蘭式多速比戟齒減速機
Flange High Reduction Hypoid Gear Reducer

■ MODEL : SLFL-O

S

LFL

-O



SMALL GEAR REDUCER SERIES

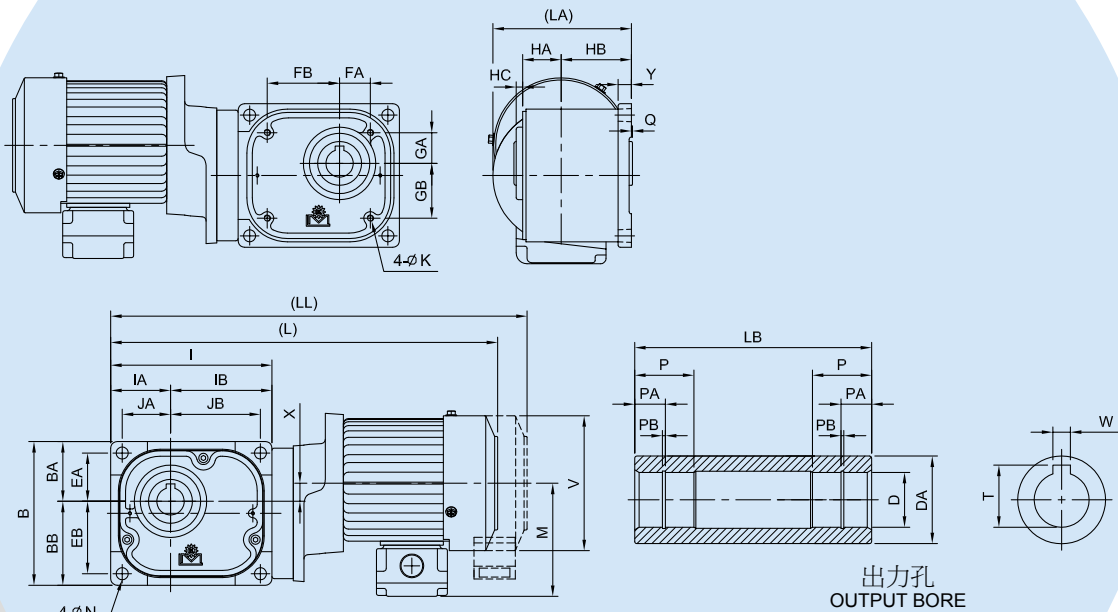

最大容許扭力 Max. Permissible Torque					
型號 Model No.	10	11	12	13	14
扭力 Torque kg-m	10	20	40	75	110

型號 Model	螺絲規格 Screw Specifications
10	M8
11	M8
12	M10
13	M12
14	M16

注：此表為尺寸 (N) 使用螺絲規格。
NOTE: This table is the size (N) using screw specifications.

馬力 Horse Power	型號 Model	減速比 Ratio	JA	JB	I	IA	IB	EA	EB	B	BA	BB	FA	FB
1/8HP (0.1kW)	10	1/250~1/2500	44	82	147	55	93	44	66	131	55	77	28	66
	11		50	90	164	62	102	50	72	146	62	84	33	73
1/4HP (0.2kW)	12		56	108	188	68	120	56	88	170	69	101	38	90
1/2HP (0.4kW)	13		70	134	234	85	149	70	104	204	85	119	48	112
1HP (0.75kW)	14		90	168	298	110	188	90	132	262	110	152	58	136

馬力 Horse Power	型號 Model	減速比 Ratio	GA	GB	HA	HB	HC	Q	Y	X	V	M	L	LL
1/8HP (0.1kW)	10	1/250~1/2500	28	50	35	64	6	1	12	16.5	137	115	375	395
	11		33	55	42	65	7	1	14	16.5	137	115	390	410
1/4HP (0.2kW)	12		38	70	44	70	7	1	16	18	137	115	445	465
1/2HP (0.4kW)	13		48	82	51	80	6	1	18	25.5	151	120	505	510
1HP (0.75kW)	14		58	100	71	98	9	1	22	32	163	128	610	620

馬力 Horse Power	型號 Model	減速比 Ratio	LA	K	N	出力孔 Output Bore							重量 Weight (KG)	
						D	DA	W	T	P	PA	PB		LB
1/8HP (0.1kW)	10	1/250~1/2500	133	M6	11	25	40	8	28.3	30	14	1.35	108	
	11		134	M8	11	30	45	8	33.3	35	17	1.35	117	
1/4HP (0.2kW)	12		138	M8	13	35	50	10	38.3	40	20	1.75	124	
1/2HP (0.4kW)	13		156	M10	15	45	65	14	48.8	50	26	1.95	140	
1HP (0.75kW)	14		184	M12	18	55	80	16	59.3	60	32	2.2	181	

- 注：
 1. 表中 () 內數字系表示輕荷重使用。
 2. 表中重量以配合三相 4P 馬達為主，其它單相、剎車、直流、特殊等馬達重量另訂。
 3. 表中 L 內數字以三相馬達為主，其它特殊馬達另訂。
 4. 如需特殊馬達規格，請洽本司業務。
 5. 以上數值若有變更，恕不另行通知。
- NOTE：
 1. Values shown in paranthesis () are used for light loading.
 2. Weights shown in the above chart are based on 3-phase 4P motors, weights for single phase, brake, DC, or special motor shall be referred to specific values.
 3. Values shown in 'L' column are based on 3-phase motor, other special motor Refer to specific motor refer to specific values.
 4. For special motor specifications, please contact our business.
 5. Above specifications are subject to change without prior notice.

■ 法蘭式多速比戟齒減速機
Flange High Reduction Hypoid Gear Reducer

■ MODEL : SLFL-D

S

LFL
-D



SMALL GEAR REDUCER SERIES

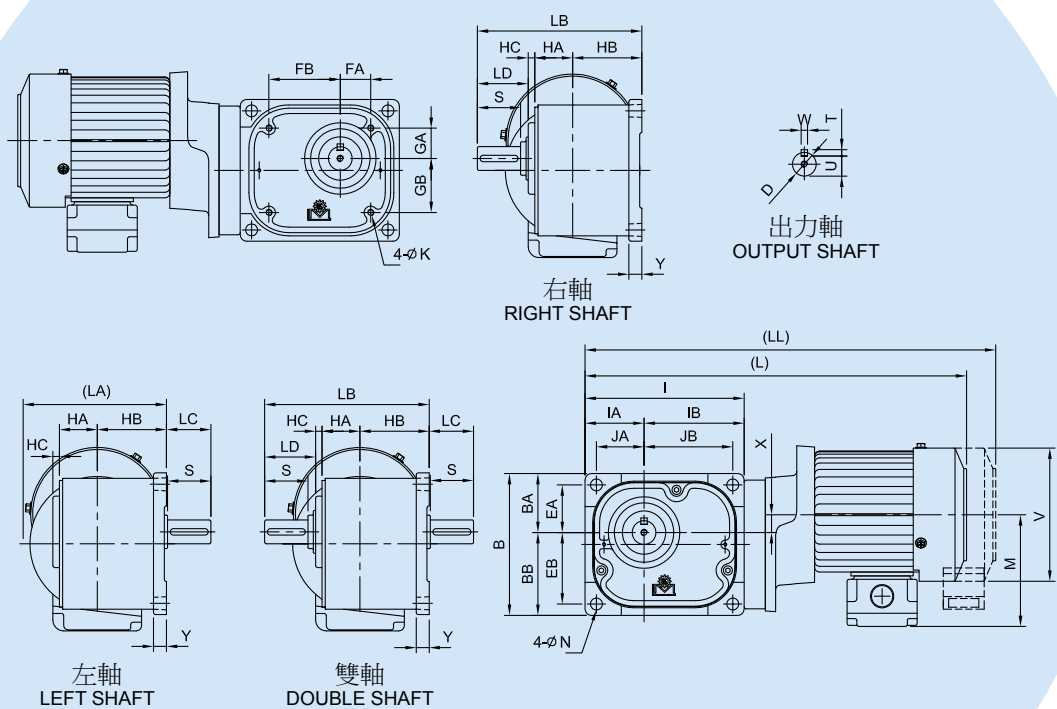

最大容許扭力 Max. Permissible Torque					
型號 Model No.	10	11	12	13	14
扭力 Torque kg-m	10	20	40	75	110

型號 Model	螺絲規格 Screw Specifications
10	M8
11	M8
12	M10
13	M12
14	M16

注：此表為尺寸 (N) 使用螺絲規格。
NOTE: This table is the size (N) using screw specifications.

unit: mm

馬力 Horse Power	型號 Model	減速比 Ratio	JA	JB	I	IA	IB	EA	EB	B	BA	BB	FA	FB
1/8HP (0.1kW)	10	1/250~1/2500	44	82	147	55	93	44	66	131	55	77	28	66
	11		50	90	164	62	102	50	72	146	62	84	33	73
1/4HP (0.2kW)	12		56	108	188	68	120	56	88	170	69	101	38	90
1/2HP (0.4kW)	13		70	134	234	85	149	70	104	204	85	119	48	112
1HP (0.75kW)	14		90	168	298	110	188	90	132	262	110	152	58	136

unit: mm

馬力 Horse Power	型號 Model	減速比 Ratio	GA	GB	HA	HB	HC	Y	X	V	M	L	LL	LA
1/8HP (0.1kW)	10	1/250~1/2500	28	50	35	64	6	12	16.5	137	115	375	395	133
	11		33	55	42	65	7	14	16.5	137	115	390	410	134
1/4HP (0.2kW)	12		38	70	44	70	7	16	18	137	115	445	465	138
1/2HP (0.4kW)	13		48	82	51	80	6	18	25.5	151	120	505	510	156
1HP (0.75kW)	14		58	100	71	98	9	22	32	163	128	610	620	184

unit: mm

馬力 Horse Power	型號 Model	減速比 Ratio	K	N	出力軸 Output Shaft								重量 Weight (KG)
					D	S	W	T	U	LB	LC	LD	
1/8HP (0.1kW)	10	1/250~1/2500	M6	11	22	40	6	6	18.5	152	41	47	
	11		M8	11	28	45	8	7	24	166	50	52	
1/4HP (0.2kW)	12		M8	13	32	55	10	8	27	183	61	62	
1/2HP (0.4kW)	13		M10	15	40	65	12	8	35	209	71	72	
1HP (0.75kW)	14		M12	18	50	75	14	9	44.5	260	81	82	

- 注：
- 表中 () 內數字系表示輕荷重使用。
 - 表中重量以配合三相 4P 馬達為主，其它單相、剎車、直流、特殊等馬達重量另訂。
 - 表中 L 內數字以三相馬達為主，其它特殊馬達另訂。
 - 如需特殊馬達規格，請洽本司業務。
 - 以上數值若有變更，恕不另行通知。
- NOTE：
- Values shown in paranthesis () are used for light loading.
 - Weights shown in the above chart are based on 3-phase 4P motors, weights for single phase, brake, DC, or special motor shall be referred to specific values.
 - Values shown in 'L' column are based on 3-phase motor, other special motor Refer to specific motor refer to specific values.
 - For special motor specifications, please contact our business.
 - Above specifications are subject to change without prior notice.

■ 臥式多速馬達自裝式戟齒減速機

Horizontal High Reduction Motor-Driver Hypoid Gear Reducer

■ MODEL : SLHBL

S

LHBL



SMALL GEAR REDUCER SERIES

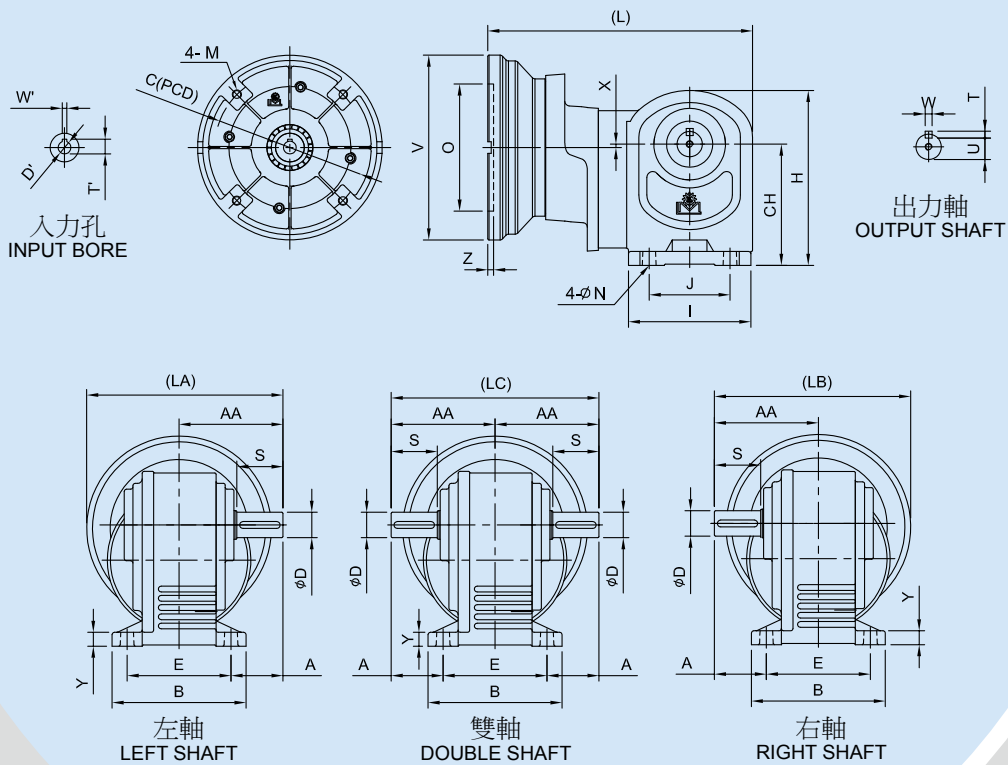

出力軸
OUTPUT SHAFT

左軸
LEFT SHAFT

雙軸
DOUBLE SHAFT

右軸
RIGHT SHAFT

型號 Model	螺絲規格 Screw Specifications
10	M8
11	M8
12	M10
13	M12
14	M16

注：此表為尺寸 (N) 使用螺絲規格。
NOTE: This table is the size (N) using screw specifications.

unit: mm

最大容許扭力 Max. Permissible Torque					
型號 Model No.	10	11	12	13	14
扭力 Torque kg-m	10	20	40	75	110

馬力 Horse Power	V	O	Z	M	C	D'	W'	T'
1/8	160	110	5	M8	130	11	4	12.8
1/4	160	110	5	M8	130	11	4	12.8
1/2	160	110	5	M8	130	14	5	16.3
1	200	130	5	M10	165	19	6	21.8

unit: mm

馬力 Horse Power	型號 Model	減速比 Ratio	A	AA	J	I	E	B	CH	H	Y	X	N	L	LA
1/8HP (0.1kW)	10	1/250~1/2500	45	90	70	106	90	116	105	152	12	3	11	235	170
	11		50	100	80	127	100	126	120	177	15	14.3	11	250	180
1/4HP (0.2kW)	12		60	120	95	154	120	150	140	208	18	13.7	13	285	200
1/2HP (0.4kW)	13		70	140	120	180	140	180	165	251	20	16.9	15	325	225
1HP (0.75kW)	14		75	165	150	210	180	230	200	310	25	15	18	400	265

unit: mm

馬力 Horse Power	型號 Model	減速比 Ratio	LB	LC	出力軸 Output Shaft					重量 Weight (KG)
					D	S	W	T	U	
1/8HP (0.1kW)	10	1/250~1/2500	170	180	22	40	6	6	18.5	
	11		180	200	28	45	8	7	24	
1/4HP (0.2kW)	12		200	240	32	55	10	8	27	
1/2HP (0.4kW)	13		225	280	40	65	12	8	35	
1HP (0.75kW)	14		265	330	50	75	14	9	44.5	

注：
1. 多速比減速機以定轉速設計，請參考齒箱最大容許扭力。
2. 以上數值若有變更，恕不另行通知。

NOTE：
1. This multistage gear reducer is designed to rotate at fixed speed. Please refer to the maximum allowable torque of the gear box.
2. Above specifications are subject to change without prior notice.

■ 法蘭式多速馬達自裝式戟齒減速機

Flange High Reduction Motor-Driver Hypoid Gear Reducer

■ MODEL : SLFBL-O

S

LFBL

-O



SMALL GEAR REDUCER SERIES

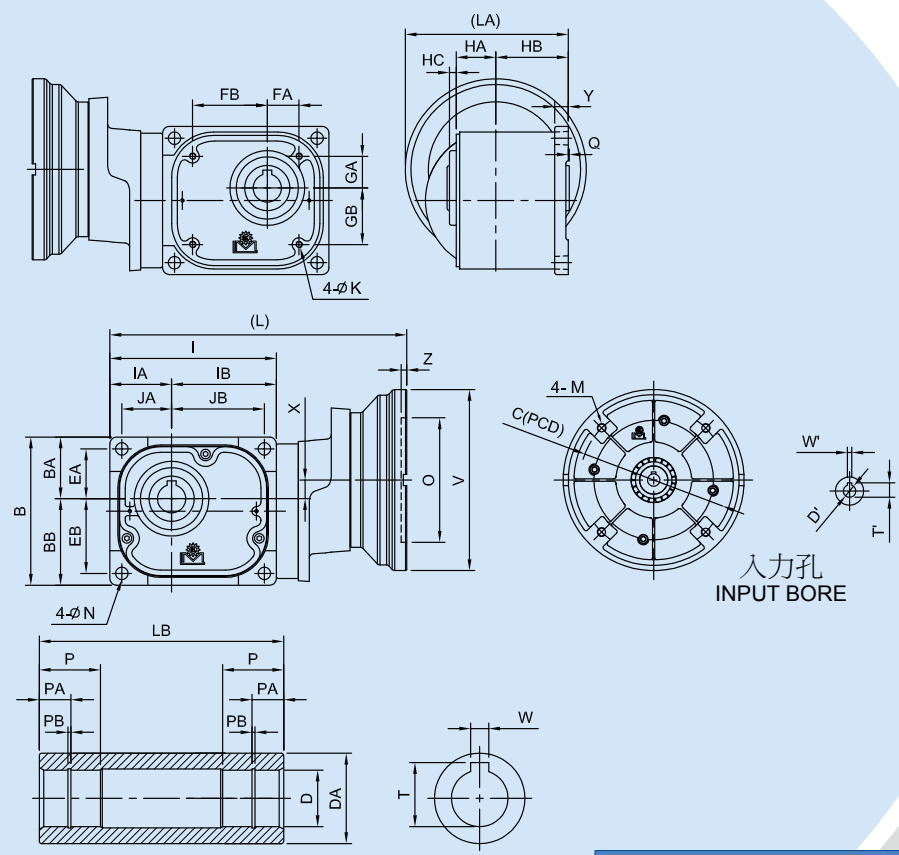

出力孔
OUTPUT BORE

最大容許扭力 Max. Permissible Torque					
型號 Model No.	10	11	12	13	14
扭力 Torque kg-m	10	20	40	75	110

unit: mm

型號 Model	螺絲規格 Screw Specifications
10	M8
11	M8
12	M10
13	M12
14	M16

注：此表為尺寸 (N) 使用螺絲規格。
NOTE: This table is the size (N) using screw specifications.

入力孔 Input Bore	馬力 Horse Power	V	O	Z	M	C	D'	W'	T'
	1/8	160	110	5	M8	130	11	4	12.8
	1/4	160	110	5	M8	130	11	4	12.8
	1/2	160	110	5	M8	130	14	5	16.3
	1	200	130	5	M10	165	19	6	21.8

unit: mm

馬力 Horse Power	型號 Model	減速比 Ratio	JA	JB	I	IA	IB	EA	EB	B	BA	BB	FA	FB
1/8HP (0.1kW)	10	1/250~1/2500	44	82	147	55	93	44	66	131	55	77	28	66
	11		50	90	164	62	102	50	72	146	62	84	33	73
1/4HP (0.2kW)	12		56	108	188	68	120	56	88	170	69	101	38	90
1/2HP (0.4kW)	13		70	134	234	85	149	70	104	204	85	119	48	112
1HP (0.75kW)	14		90	168	298	110	188	90	132	262	110	152	58	136

unit: mm

馬力 Horse Power	型號 Model	減速比 Ratio	GA	GB	HA	HB	HC	Q	Y	X	L	LA	K	N
1/8HP (0.1kW)	10	1/250~1/2500	28	50	35	64	6	1	12	16.5	265	144	M6	11
	11		33	55	42	65	7	1	14	16.5	285	145	M8	11
1/4HP (0.2kW)	12		38	70	44	70	7	1	16	18	315	150	M8	13
1/2HP (0.4kW)	13		48	82	51	80	6	1	18	25.5	370	160	M10	15
1HP (0.75kW)	14		58	100	71	98	9	1	22	32	475	198	M12	18

unit: mm

馬力 Horse Power	型號 Model	減速比 Ratio	出力孔 Output Bore							重量 Weight (KG)	
			D	DA	W	T	P	PA	PB		LB
1/8HP (0.1kW)	10	1/250~1/2500	25	40	8	28.3	30	14	1.35	108	
	11		30	45	8	33.3	35	17	1.35	117	
1/4HP (0.2kW)	12		35	50	10	38.3	40	20	1.75	124	
1/2HP (0.4kW)	13		45	65	14	48.8	50	26	1.95	140	
1HP (0.75kW)	14		55	80	16	59.3	60	32	2.2	181	

注：
1. 多速比減速機以定轉速設計，請參考齒箱最大容許扭力。
2. 以上數值若有變更，恕不另行通知。

NOTE：
1. This multistage gear reducer is designed to rotate at fixed speed. Please refer to the maximum allowable torque of the gear box.
2. Above specifications are subject to change without prior notice.

■ 法蘭式多速馬達自裝式戟齒減速機

Flange High Reduction Motor-Driver Hypoid Gear Reducer

■ MODEL : SLFBL-D

S

LFBL
-D



SMALL GEAR REDUCER SERIES

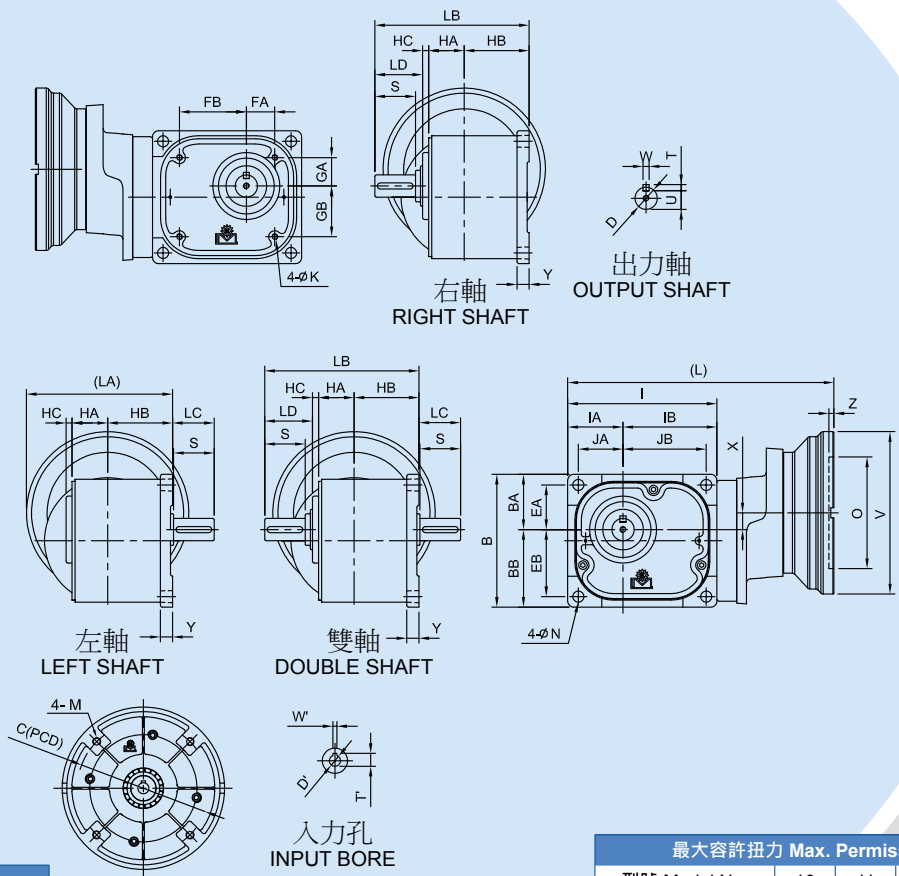

型號 Model	螺絲規格 Screw Specifications
10	M8
11	M8
12	M10
13	M12
14	M16

注：此表為尺寸 (N) 使用螺絲規格。
NOTE: This table is the size (N) using screw specifications.

最大容許扭力 Max. Permissible Torque					
型號 Model No.	10	11	12	13	14
扭力 Torque kg-m	10	20	40	75	110

unit: mm

馬力 Horse Power	V	O	Z	M	C	D'	W'	T'
1/8	160	110	5	M8	130	11	4	12.8
1/4	160	110	5	M8	130	11	4	12.8
1/2	160	110	5	M8	130	14	5	16.3
1	200	130	5	M10	165	19	6	21.8

unit: mm

馬力 Horse Power	型號 Model	減速比 Ratio	JA	JB	I	IA	IB	EA	EB	B	BA	BB	FA	FB
1/8HP (0.1kW)	10	1/250~1/2500	44	82	147	55	93	44	66	131	55	77	28	66
	11		50	90	164	62	102	50	72	146	62	84	33	73
1/4HP (0.2kW)	12		56	108	188	68	120	56	88	170	69	101	38	90
1/2HP (0.4kW)	13		70	134	234	85	149	70	104	204	85	119	48	112
1HP (0.75kW)	14		90	168	298	110	188	90	132	262	110	152	58	136

unit: mm

馬力 Horse Power	型號 Model	減速比 Ratio	GA	GB	HA	HB	HC	Y	X	L	LA	K	N
1/8HP (0.1kW)	10	1/250~1/2500	28	50	35	64	6	12	16.5	265	144	M6	11
	11		33	55	42	65	7	14	16.5	285	145	M8	11
1/4HP (0.2kW)	12		38	70	44	70	7	16	18	315	150	M8	13
1/2HP (0.4kW)	13		48	82	51	80	6	18	25.5	370	160	M10	15
1HP (0.75kW)	14		58	100	71	98	9	22	32	475	198	M12	18

unit: mm

馬力 Horse Power	型號 Model	減速比 Ratio	出力軸 Output Shaft							重量 Weight (KG)	
			D	S	W	T	U	LB	LC		LD
1/8HP (0.1kW)	10	1/250~1/2500	22	40	6	6	18.5	152	41	47	
	11		28	45	8	7	24	166	50	52	
1/4HP (0.2kW)	12		32	55	10	8	27	183	61	62	
1/2HP (0.4kW)	13		40	65	12	8	35	209	71	72	
1HP (0.75kW)	14		50	75	14	9	44.5	260	81	82	

注：
1. 多速比減速機以定轉速設計，請參考齒箱最大容許扭力。
2. 以上數值若有變更，恕不另行通知。

NOTE：
1. This multistage gear reducer is designed to rotate at fixed speed. Please refer to the maximum allowable torque of the gear box.
2. Above specifications are subject to change without prior notice.

■ 臥式多速雙軸戟齒減速機

Horizontal High Reduction Double-Axle Hypoid Gear Reducer

■ MODEL : SLHDL

S

LHDL



SMALL GEAR REDUCER SERIES

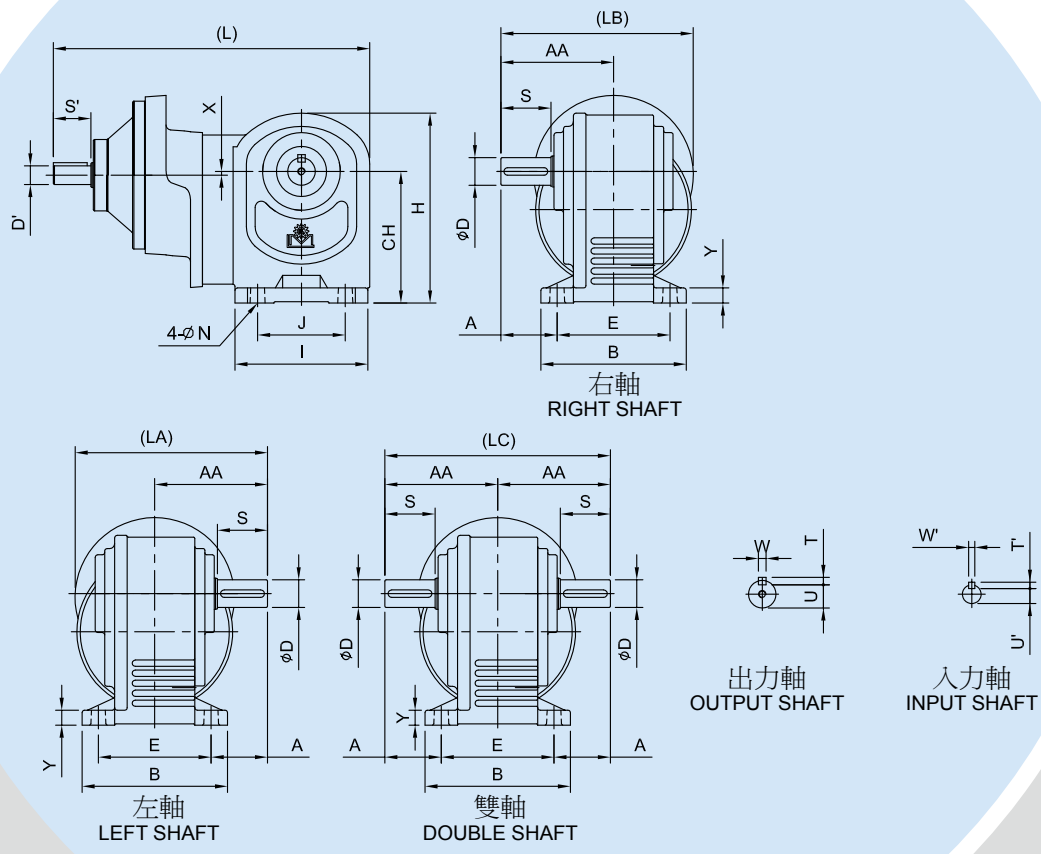

型號 Model	螺絲規格 Screw Specifications
10	M8
11	M8
12	M10
13	M12
14	M16

注：此表為尺寸 (N) 使用螺絲規格。
NOTE: This table is the size (N) using screw specifications.

unit: mm

最大容許扭力 Max. Permissible Torque					
型號 Model No.	10	11	12	13	14
扭力 Torque kg-m	10	20	40	75	110

	馬力 Horse Power	D'	S'	W'	T'	U'
入力軸 Input Shaft	1/8	12	25	4	4	9.5
	1/4	12	25	4	4	9.5
	1/2	15	30	5	5	12
	1	20	35	6	6	16.5

unit: mm

馬力 Horse Power	型號 Model	減速比 Ratio	A	AA	J	I	E	B	CH	H	Y	X	N	L	LA
1/8HP (0.1kW)	10	1/250~1/2500	45	90	70	106	90	116	105	152	12	3	11	250	155
	11		50	100	80	127	100	126	120	177	15	14.3	11	265	165
1/4HP (0.2kW)	12		60	120	95	154	120	150	140	208	18	13.7	13	305	196
1/2HP (0.4kW)	13		70	140	120	180	140	180	165	251	20	16.9	15	350	225
1HP (0.75kW)	14		75	165	150	210	180	230	200	310	25	15	18	430	252

unit: mm

馬力 Horse Power	型號 Model	減速比 Ratio	LB	LC	出力軸 Output Shaft					重量 Weight (KG)
					D	S	W	T	U	
1/8HP (0.1kW)	10	1/250~1/2500	155	180	22	40	6	6	18.5	
	11		165	200	28	45	8	7	24	
1/4HP (0.2kW)	12		196	240	32	55	10	8	27	
1/2HP (0.4kW)	13		225	280	40	65	12	8	35	
1HP (0.75kW)	14		252	330	50	75	14	9	44.5	

注：
1. 多速比減速機以定轉速設計，請參考齒箱最大容許扭力。
2. 以上數值若有變更，恕不另行通知。

NOTE:
1. This multistage gear reducer is designed to rotate at fixed speed. Please refer to the maximum allowable torque of the gear box.
2. Above specifications are subject to change without prior notice.

■ 法蘭式多速雙軸戟齒減速機

Flange High Reduction Double-Axle Hypoid Gear Reducer

■ MODEL : SLFDL-O

S

LFDL
-O



SMALL GEAR REDUCER SERIES

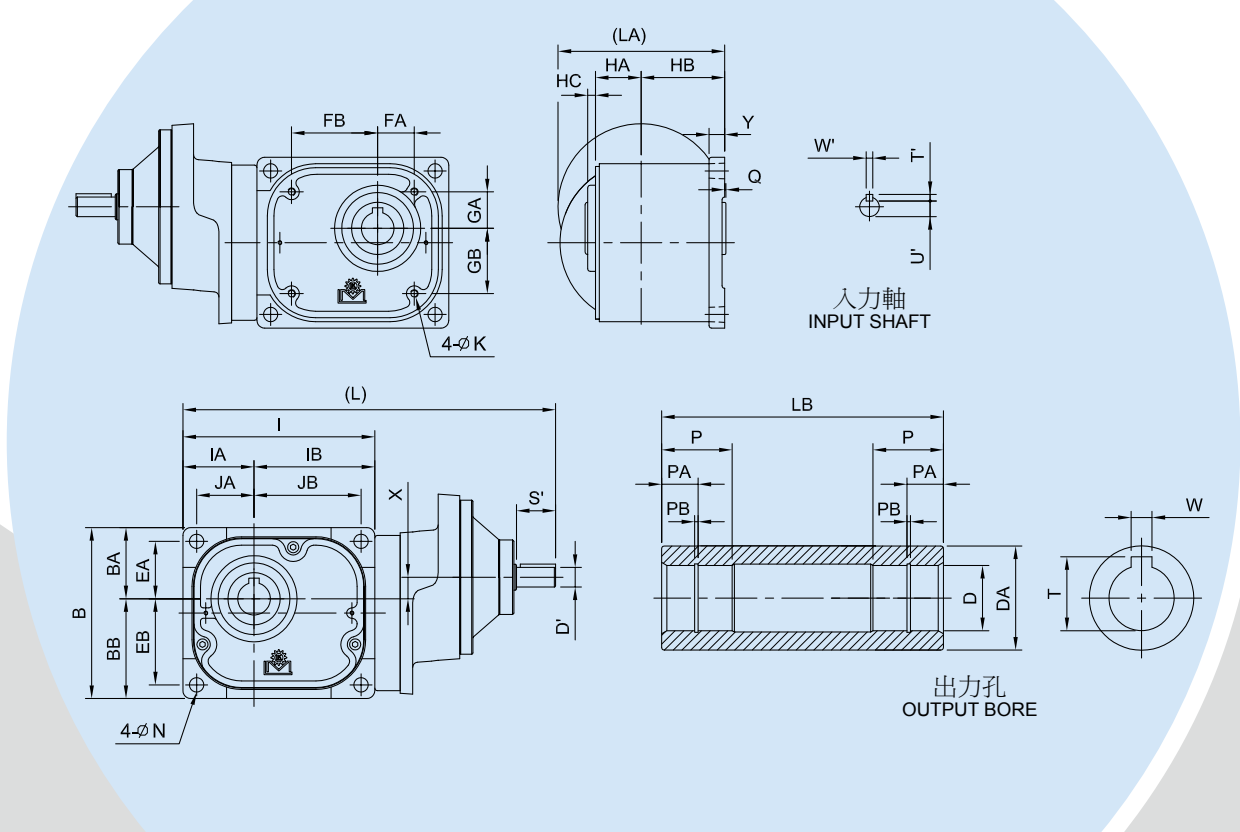

型號 Model	螺絲規格 Screw Specifications
10	M8
11	M8
12	M10
13	M12
14	M16

注：此表為尺寸 (N) 使用螺絲規格。
NOTE: This table is the size (N) using screw specifications.

最大容許扭力 Max. Permissible Torque					
型號 Model No.	10	11	12	13	14
扭力 Torque kg-m	10	20	40	75	110

unit: mm

馬力 Horse Power	D'	S'	W'	T'	U'
1/8	12	25	4	4	9.5
1/4	12	25	4	4	9.5
1/2	15	30	5	5	12
1	20	35	6	6	16.5

unit: mm

馬力 Horse Power	型號 Model	減速比 Ratio	JA	JB	I	IA	IB	EA	EB	B	BA	BB	FA	FB
1/8HP (0.1kW)	10	1/250~1/2500	44	82	147	55	93	44	66	131	55	77	28	66
	11		50	90	164	62	102	50	72	146	62	84	33	73
1/4HP (0.2kW)	12		56	108	188	68	120	56	88	170	69	101	38	90
1/2HP (0.4kW)	13		70	134	234	85	149	70	104	204	85	119	48	112
1HP (0.75kW)	14		90	168	298	110	188	90	132	262	110	152	58	136

unit: mm

馬力 Horse Power	型號 Model	減速比 Ratio	GA	GB	HA	HB	HC	Q	Y	X	L	LA	K	N
1/8HP (0.1kW)	10	1/250~1/2500	28	50	35	64	6	1	12	16.5	285	129	M6	11
	11		33	55	42	65	7	1	14	16.5	300	130	M8	11
1/4HP (0.2kW)	12		38	70	44	70	7	1	16	18	335	138	M8	13
1/2HP (0.4kW)	13		48	82	51	80	6	1	18	25.5	395	156	M10	15
1HP (0.75kW)	14		58	100	71	98	9	1	22	32	505	184	M12	18

unit: mm

馬力 Horse Power	型號 Model	減速比 Ratio	出力孔 Output Bore							重量 Weight (KG)	
			D	DA	W	T	P	PA	PB		LB
1/8HP (0.1kW)	10	1/250~1/2500	25	40	8	28.3	30	14	1.35	108	
	11		30	45	8	33.3	35	17	1.35	117	
1/4HP (0.2kW)	12		35	50	10	38.3	40	20	1.75	124	
1/2HP (0.4kW)	13		45	65	14	48.8	50	26	1.95	140	
1HP (0.75kW)	14		55	80	16	59.3	60	32	2.2	181	

注：
1. 多速比減速機以定轉速設計，請參考齒箱最大容許扭力。
2. 以上數值若有變更，恕不另行通知。

NOTE：
1. This multistage gear reducer is designed to rotate at fixed speed. Please refer to the maximum allowable torque of the gear box.
2. Above specifications are subject to change without prior notice.

■ 法蘭式多速雙軸戟齒減速機

Flange High Reduction Double-Axle Hypoid Gear Reducer

■ MODEL : SLFDL-D

S

LFDL
-D



SMALL GEAR REDUCER SERIES

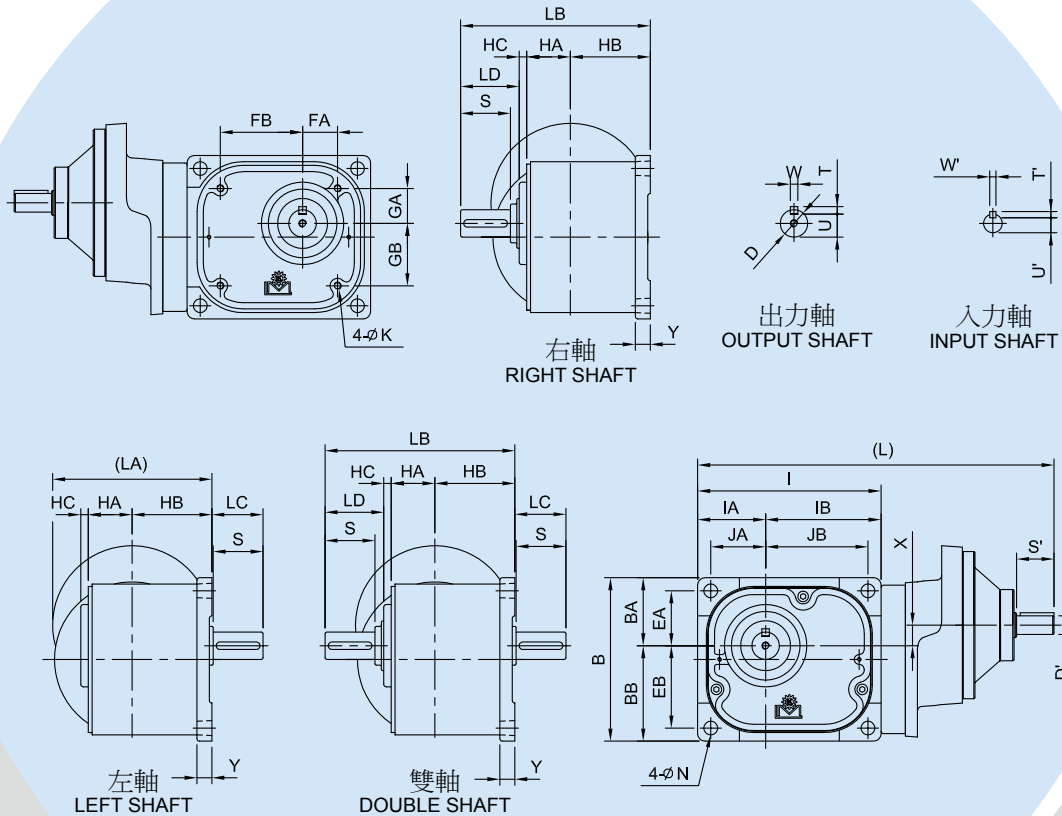

型號 Model	螺絲規格 Screw Specifications
10	M8
11	M8
12	M10
13	M12
14	M16

注：此表為尺寸 (N) 使用螺絲規格。
NOTE: This table is the size (N) using screw specifications.

最大容許扭力 Max. Permissible Torque					
型號 Model No.	10	11	12	13	14
扭力 Torque kg-m	10	20	40	75	110

unit: mm

輸入軸 Input Shaft	馬力 Horse Power	D'	S'	W'	T'	U'
	1/8	12	25	4	4	9.5
	1/4	12	25	4	4	9.5
	1/2	15	30	5	5	12
	1	20	35	6	6	16.5

unit: mm

馬力 Horse Power	型號 Model	減速比 Ratio	JA	JB	I	IA	IB	EA	EB	B	BA	BB	FA	FB
1/8HP (0.1kW)	10	1/250~1/2500	44	82	147	55	93	44	66	131	55	77	28	66
	11		50	90	164	62	102	50	72	146	62	84	33	73
1/4HP (0.2kW)	12		56	108	188	68	120	56	88	170	69	101	38	90
1/2HP (0.4kW)	13		70	134	234	85	149	70	104	204	85	119	48	112
1HP (0.75kW)	14		90	168	298	110	188	90	132	262	110	152	58	136

unit: mm

馬力 Horse Power	型號 Model	減速比 Ratio	GA	GB	HA	HB	HC	Y	X	L	LA	K	N
1/8HP (0.1kW)	10	1/250~1/2500	28	50	35	64	6	12	16.5	285	129	M6	11
	11		33	55	42	65	7	14	16.5	300	130	M8	11
1/4HP (0.2kW)	12		38	70	44	70	7	16	18	335	138	M8	13
1/2HP (0.4kW)	13		48	82	51	80	6	18	25.5	395	156	M10	15
1HP (0.75kW)	14		58	100	71	98	9	22	32	505	184	M12	18

unit: mm

馬力 Horse Power	型號 Model	減速比 Ratio	輸出軸 Output Shaft							重量 Weight (KG)	
			D	S	W	T	U	LB	LC		LD
1/8HP (0.1kW)	10	1/250~1/2500	22	40	6	6	18.5	152	41	47	
	11		28	45	8	7	24	166	50	52	
1/4HP (0.2kW)	12		32	55	10	8	27	183	61	62	
1/2HP (0.4kW)	13		40	65	12	8	35	209	71	72	
1HP (0.75kW)	14		50	75	14	9	44.5	260	81	82	

注：
1. 多速比減速機以定轉速設計，請參考齒箱最大容許扭力。
2. 以上數值若有變更，恕不另行通知。

NOTE：
1. This multistage gear reducer is designed to rotate at fixed speed. Please refer to the maximum allowable torque of the gear box.
2. Above specifications are subject to change without prior notice.

MEMO

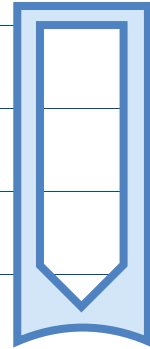

Handwriting practice area consisting of ten horizontal blue lines.

Table with 5 rows and 1 column, containing horizontal lines for text entry.



同心軸戟齒輪減速機 Hypoid Gear Reducer (Concentric Shaft)















機種型號表示 Indication of Model Numbers

SK	□	10	S	O	1/8	A	1/5
機型 Type SK	機種 Type □: 無 None B: 自裝式 Motor-Driver D: 雙軸式 Double-Axle L: 多速比 High Reduction BL: 多速比自裝式 High Reduction Motor-Driver DL: 多速比雙軸式 High Reduction Double-Axle	型號 Model 09 10 11 12 13 14	法蘭型式 Flange Type S: 短框 Short Frame L: 長框 Long Frame	出力軸表示 Output O: 中空軸 Hollow Shaft D: 實心軸 Solid Shaft	馬力 Horse Power 1/8 HP 1/4 HP 1/2 HP 1 HP 2 HP 3 HP	馬達 Motor A: 三相 3-Phase B: 剎車 Brake C: 特殊 Special S: 單相 Single Phase	減速比 Ratio 1/5 ~ 1/2500 ※

※ 表中減速比以公稱速比，如需實際速比，請另告知。The reduction ration in the table are nominal ratios. Please contact us if your need actual ratios.

產品樣式選擇 Selection Of Type

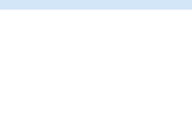
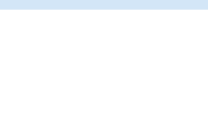
	SK □ - (S/L) O	SK □ - (S/L) D
<div style="border: 1px dashed red; padding: 5px; text-align: center;"> 標準型 Standard </div>	中空軸式 Solid Shaft 	實心軸式 Hollow Shaft 
<div style="border: 1px solid blue; padding: 5px; text-align: center;"> B 自裝式 Motor Driver </div>	SK-(S/L)O 	SK-(S/L)D 
<div style="border: 1px solid blue; padding: 5px; text-align: center;"> D 雙軸式 Double Axle </div>	SKB-(S/L)O 	SKB-(S/L)D 
<div style="border: 1px solid blue; padding: 5px; text-align: center;"> L 多速比 High Reduction </div>	SKD-(S/L)O 	SKD-(S/L)D 
<div style="border: 1px solid blue; padding: 5px; text-align: center;"> BL 多速比自裝式 High Reduction Motor Driver </div>	SKL-(S/L)O 	SKL-(S/L)D 
<div style="border: 1px solid blue; padding: 5px; text-align: center;"> DL 多速比雙軸式 High Reduction Double Axle </div>	SKBL-(S/L)O 	SKBL-(S/L)D 
	SKDL-(S/L)O 	SKDL-(S/L)D 

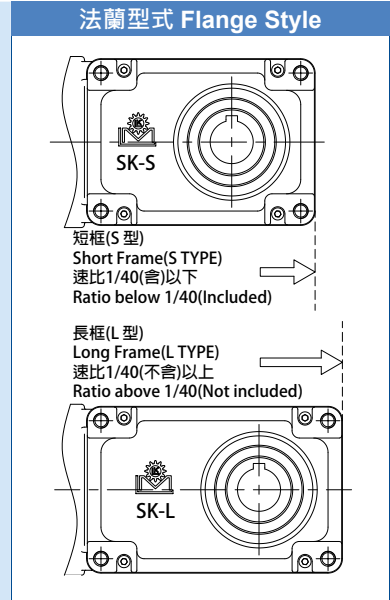



■ 減速機安裝方向
Reducer Installation Direction

■ MODEL : SK

代號 Code	示意圖 Schematic Diagram
F1	
F2	
F3	

代號 Code	示意圖 Schematic Diagram
F4	
F5	

■ 減速機線盒方向
Reducer Terminal Box Direction

代號 Code	示意圖 Schematic Diagram
盒上 UP	
盒左 LEFT	

代號 Code	示意圖 Schematic Diagram
盒下 DOWN	
盒右 RIGHT	

同心軸載齒減速機 Hypoid Gear Reducer(Concentric Shaft)

MODEL : SK-SO / SK-LO

SK-O

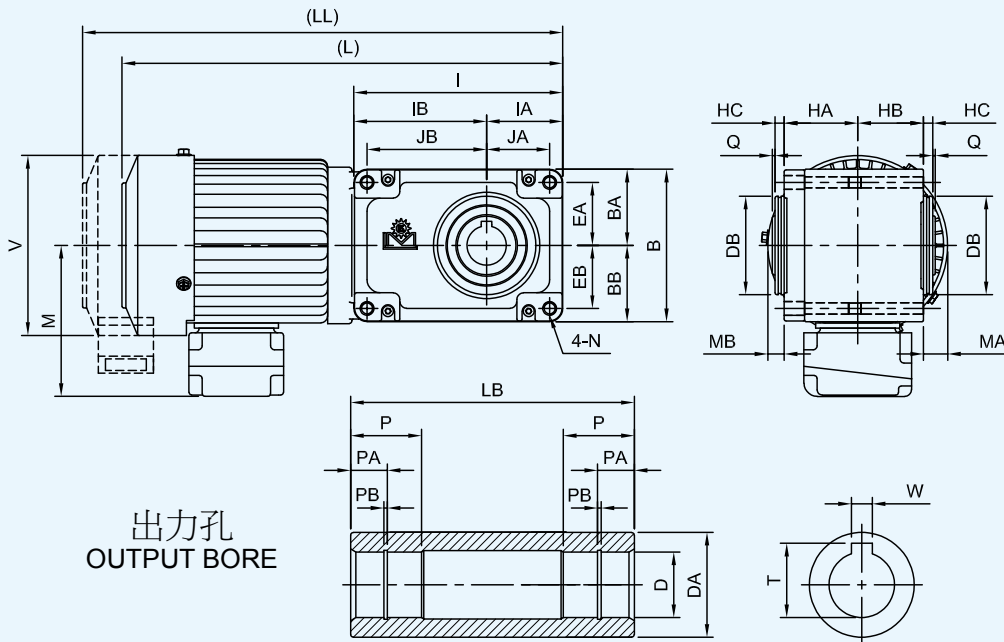

unit: mm

馬力 Horse Power	型號 Model	減速比 Ratio	JA	JB	I	IA	IB	EA	EB	B	BA	BB
1/8HP (0.1kW)	09	1/5~1/100(1/120)	38.5	68.5	127	48.5	78.5	38.5	38.5	97	48.5	48.5
	10-S	1/5~1/40	43.5	76.5	139.5	53.5	86	43.5	43.5	107	53.5	53.5
	10-L	1/50~1/200(1/240)	43.5	95.5	158.5	53.5	105	43.5	43.5	107	53.5	53.5
1/4HP (0.2kW)	09	1/5~1/50(1/60~1/120)	38.5	68.5	127	48.5	78.5	38.5	38.5	97	48.5	48.5
	10-S	1/5~1/40	43.5	76.5	139.5	53.5	86	43.5	43.5	107	53.5	53.5
	10-L	1/50~1/100(1/120~1/240)	43.5	95.5	158.5	53.5	105	43.5	43.5	107	53.5	53.5
	11-S	1/5~1/40	48	91	159	58	101	48	48	116	58	58
	11-L	1/45~1/200(1/220~1/260)	46	110	180	58	122	46	46	116	58	58
1/2HP (0.4kW)	11-S	1/5~1/40	48	91	159	58	101	48	48	116	58	58
	11-L	1/45~1/100(1/120~1/260)	46	110	180	58	122	46	46	116	58	58
	12-S	1/5~1/40	56	105	185	68	117	56	56	136	68	68
	12-L	1/50~1/200(1/225~1/250)	54	140	222	68	154	54	54	136	68	68
1HP (0.75kW)	12-S	1/5~1/40	56	105	185	68	117	56	56	136	68	68
	12-L	1/50~1/100(1/120~1/250)	54	140	222	68	154	54	54	136	68	68
	13-S	1/5~1/40	73	134	235	87	148	73	73	174	87	87
2HP (1.5kW)	13-L	1/50~1/200(1/240~1/260)	69	167	272	87	185	69	69	174	87	87
	13-S	1/5~1/40	73	134	235	87	148	73	73	174	87	87
	13-L	1/50~1/100(1/125~1/260)	69	167	272	87	185	69	69	174	87	87
	14-S	1/5~1/40	102	170	304	118	186	90	90	212	106	106
3HP (2.2kW)	14-L	1/50~1/160(1/180~1/285)	94	198	336	116	220	108	108	260	130	130
	14-S	1/5~1/40	102	170	304	118	186	90	90	212	106	106
	14-L	1/50~1/120(1/160~1/285)	94	198	336	116	220	108	108	260	130	130

SMALL GEAR REDUCER SERIES

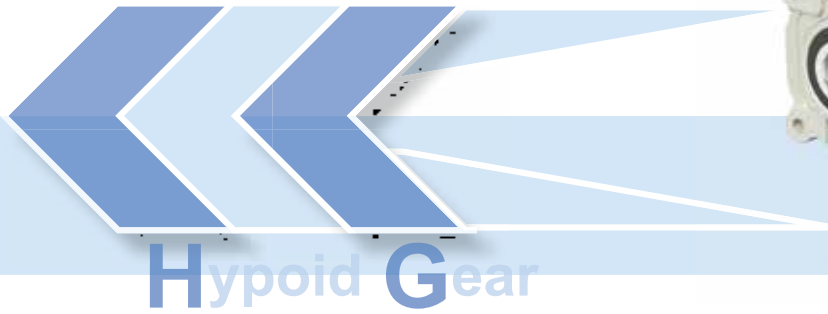

unit: mm

馬力 Horse Power	型號 Model	減速比 Ratio	HA	HB	HC	Q	V	M	L	LL	MA	MB	N
1/8HP (0.1kW)	09	1/5~1/100(1/120)	47	31	7	2	123	108	315	330	30.5	14.5	M10
	10-S	1/5~1/40	50	50	7	2	137	115	325	345	18.5	18.5	M10
	10-L	1/50~1/200(1/240)	50	50	7	2	137	115	340	360	18.5	18.5	M10
1/4HP (0.2kW)	09	1/5~1/50(1/60~1/120)	47	31	7	2	123	108	330	340	30.5	14.5	M10
	10-S	1/5~1/40	50	50	7	2	137	115	345	365	18.5	18.5	M10
	10-L	1/50~1/100(1/120~1/240)	50	50	7	2	137	115	360	380	18.5	18.5	M10
	11-S	1/5~1/40	56	50	7	2	137	115	360	380	18.5	12.5	M10
	11-L	1/45~1/200(1/220~1/260)	56	50	7	2	137	115	380	400	18.5	12.5	M12
1/2HP (0.4kW)	11-S	1/5~1/40	56	50	7	2	137	115	375	395	18.5	12.5	M10
	11-L	1/45~1/100(1/120~1/260)	56	50	7	2	137	115	395	415	18.5	12.5	M12
	12-S	1/5~1/40	67.5	56.5	7	2	151	121	395	400	19	8	M12
	12-L	1/50~1/200(1/225~1/250)	67.5	56.5	7	2	151	121	435	440	19	8	M16
1HP (0.75kW)	12-S	1/5~1/40	67.5	56.5	7	2	151	121	420	425	19	8	M12
	12-L	1/50~1/100(1/120~1/250)	67.5	56.5	7	2	151	121	460	465	19	8	M16
	13-S	1/5~1/40	85	65	7	2	163	131	460	470	16.5	-	M16
	13-L	1/50~1/200(1/240~1/260)	85	65	7	2	163	131	500	510	16.5	-	M16
2HP (1.5kW)	13-S	1/5~1/40	85	65	7	2	163	131	480	490	16.5	-	M16
	13-L	1/50~1/100(1/125~1/260)	85	65	7	2	163	131	520	530	16.5	-	M16
	14-S	1/5~1/40	92.5	92.5	8	2	181	138	570	590	-	-	M16
	14-L	1/50~1/160(1/180~1/285)	92.5	92.5	8	2	181	138	605	620	-	-	M20
3HP (2.2kW)	14-S	1/5~1/40	92.5	92.5	8	2	181	138	610	630	-	-	M16
	14-L	1/50~1/120(1/160~1/285)	92.5	92.5	8	2	181	138	645	660	-	-	M20

unit: mm

馬力 Horse Power	型號 Model	減速比 Ratio	出力孔 Output Bore									重量 Weight (KG)
			D	DA	DB	W	T	P	PA	PB	LB	
1/8HP (0.1kW)	09	1/5~1/100(1/120)	20	30	53	6	22.8	25	13	1.15	96	
	10-S	1/5~1/40	25	40	66	8	28.3	30	14	1.35	118	
	10-L	1/50~1/200(1/240)	25	40	66	8	28.3	30	14	1.35	118	
1/4HP (0.2kW)	09	1/5~1/50(1/60~1/120)	20	30	53	6	22.8	25	13	1.15	96	
	10-S	1/5~1/40	25	40	66	8	28.3	30	14	1.35	118	
	10-L	1/50~1/100(1/120~1/240)	25	40	66	8	28.3	30	14	1.35	118	
	11-S	1/5~1/40	30	45	75	8	33.3	35	17	1.35	124	
	11-L	1/45~1/200(1/220~1/260)	30	45	75	8	33.3	35	17	1.35	124	
1/2HP (0.4kW)	11-S	1/5~1/40	30	45	75	8	33.3	35	17	1.35	124	
	11-L	1/45~1/100(1/120~1/260)	30	45	75	8	33.3	35	17	1.35	124	
	12-S	1/5~1/40	35	50	85	10	38.3	40	20	1.75	142	
1HP (0.75kW)	12-L	1/50~1/200(1/225~1/250)	35	50	85	10	38.3	40	20	1.75	142	
	12-S	1/5~1/40	35	50	85	10	38.3	40	20	1.75	142	
	12-L	1/50~1/100(1/120~1/250)	35	50	85	10	38.3	40	20	1.75	142	
	13-S	1/5~1/40	45	65	100	14	48.8	50	26	1.95	168	
2HP (1.5kW)	13-L	1/50~1/200(1/240~1/260)	45	65	100	14	48.8	50	26	1.95	168	
	13-S	1/5~1/40	45	65	100	14	48.8	50	26	1.95	168	
	13-L	1/50~1/100(1/125~1/260)	45	65	100	14	48.8	50	26	1.95	168	
	14-S	1/5~1/40	55	80	120	16	59.3	60	32	2.2	205	
3HP (2.2kW)	14-L	1/50~1/160(1/180~1/285)	55	80	120	16	59.3	60	32	2.2	205	
	14-S	1/5~1/40	55	80	120	16	59.3	60	32	2.2	205	
	14-L	1/50~1/120(1/160~1/285)	55	80	120	16	59.3	60	32	2.2	205	

注:

- 表中 () 內數字系表示輕荷重使用。
- 表中重量以配合三相 4P 馬達為主，其它單相、剎車、直流、特殊等馬達重量另訂。
- 表中 L 內數字以三相馬達為主，其它特殊馬達另訂。
- 如需特殊馬達規格，請洽本司業務。
- 以上數值若有變更，恕不另行通知。

NOTE:

- Values shown in paranthesis () are used for light loading.
- Weights shown in the above chart are based on 3-phase 4P motors, weights for single phase, brake, DC, or special motor shall be referred to specific values.
- Values shown in 'L' column are based on 3-phase motor, other special motor Refer to specific motor refet to specific values.
- For special motor specifications, please contact our business.
- Above specifications are subject to change without prior notice.

同心軸戟齒減速機

Hypoid Gear Reducer(Concentric Shaft)

MODEL : SK-SD / SK-LD

SK-D

出力軸螺絲孔 Output Shaft Screw Hole	
型號 Model	螺絲規格 Screw Specifications
09	M6
10	M6
11	M8
12	M10
13	M12
14	M16

注：SK 系列通用。
NOTE: Common for SK series.

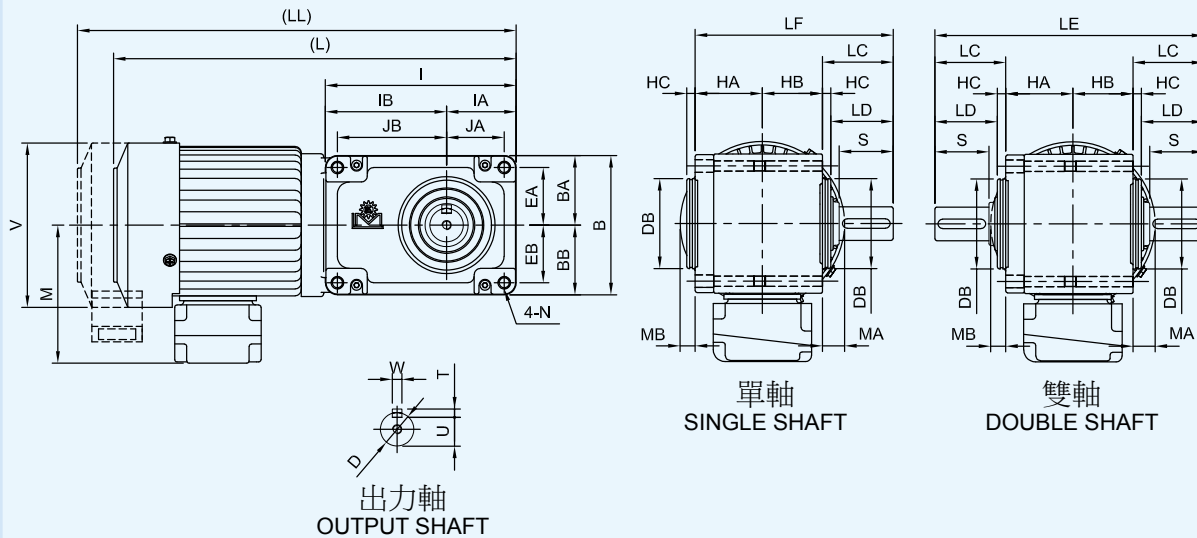

unit: mm

馬力 Horse Power	型號 Model	減速比 Ratio	JA	JB	I	IA	IB	EA	EB	B	BA	BB
1/8HP (0.1kW)	09	1/5~1/100(1/120)	38.5	68.5	127	48.5	78.5	38.5	38.5	97	48.5	48.5
	10-S	1/5~1/40	43.5	76.5	139.5	53.5	86	43.5	43.5	107	53.5	53.5
	10-L	1/50~1/200(1/240)	43.5	95.5	158.5	53.5	105	43.5	43.5	107	53.5	53.5
1/4HP (0.2kW)	09	1/5~1/50(1/60~1/120)	38.5	68.5	127	48.5	78.5	38.5	38.5	97	48.5	48.5
	10-S	1/5~1/40	43.5	76.5	139.5	53.5	86	43.5	43.5	107	53.5	53.5
	10-L	1/50~1/100(1/120~1/240)	43.5	95.5	158.5	53.5	105	43.5	43.5	107	53.5	53.5
	11-S	1/5~1/40	48	91	159	58	101	48	48	116	58	58
	11-L	1/45~1/200(1/220~1/260)	46	110	180	58	122	46	46	116	58	58
1/2HP (0.4kW)	11-S	1/5~1/40	48	91	159	58	101	48	48	116	58	58
	11-L	1/45~1/100(1/120~1/260)	46	110	180	58	122	46	46	116	58	58
	12-S	1/5~1/40	56	105	185	68	117	56	56	136	68	68
	12-L	1/50~1/200(1/225~1/250)	54	140	222	68	154	54	54	136	68	68
1HP (0.75kW)	12-S	1/5~1/40	56	105	185	68	117	56	56	136	68	68
	12-L	1/50~1/100(1/120~1/250)	54	140	222	68	154	54	54	136	68	68
	13-S	1/5~1/40	73	134	235	87	148	73	73	174	87	87
2HP (1.5kW)	13-L	1/50~1/200(1/240~1/260)	69	167	272	87	185	69	69	174	87	87
	13-S	1/5~1/40	73	134	235	87	148	73	73	174	87	87
	14-S	1/5~1/40	102	170	304	118	186	90	90	212	106	106
	14-L	1/50~1/160(1/180~1/285)	94	198	336	116	220	108	108	260	130	130
3HP (2.2kW)	14-S	1/5~1/40	102	170	304	118	186	90	90	212	106	106
	14-L	1/50~1/120(1/160~1/285)	94	198	336	116	220	108	108	260	130	130

SMALL GEAR REDUCER SERIES

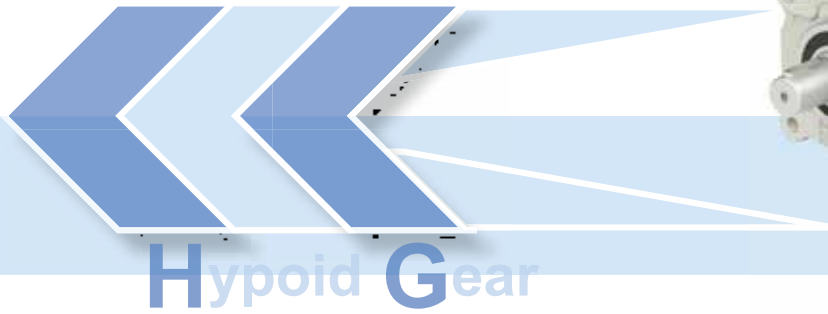

unit: mm

馬力 Horse Power	型號 Model	減速比 Ratio	HA	HB	HC	V	M	L	LL	MA	MB	N
1/8HP (0.1kW)	09	1/5~1/100(1/120)	47	31	7	123	108	315	330	30.5	14.5	M10
	10-S	1/5~1/40	50	50	7	137	115	325	345	18.5	18.5	M10
	10-L	1/50~1/200(1/240)	50	50	7	137	115	340	360	18.5	18.5	M10
1/4HP (0.2kW)	09	1/5~1/50(1/60~1/120)	47	31	7	123	108	330	340	30.5	14.5	M10
	10-S	1/5~1/40	50	50	7	137	115	345	365	18.5	18.5	M10
	10-L	1/50~1/100(1/120~1/240)	50	50	7	137	115	360	380	18.5	18.5	M10
	11-S	1/5~1/40	56	50	7	137	115	360	380	18.5	12.5	M10
	11-L	1/45~1/200(1/220~1/260)	56	50	7	137	115	380	400	18.5	12.5	M12
1/2HP (0.4kW)	11-S	1/5~1/40	56	50	7	137	115	375	395	18.5	12.5	M10
	11-L	1/45~1/100(1/120~1/260)	56	50	7	137	115	395	415	18.5	12.5	M12
	12-S	1/5~1/40	67.5	56.5	7	151	121	395	400	19	8	M12
1HP (0.75kW)	12-L	1/50~1/200(1/225~1/250)	67.5	56.5	7	151	121	435	440	19	8	M16
	12-S	1/5~1/40	67.5	56.5	7	151	121	420	425	19	8	M12
	13-S	1/50~1/100(1/120~1/250)	67.5	56.5	7	151	121	460	465	19	8	M16
	13-S	1/5~1/40	85	65	7	163	131	460	470	16.5	-	M16
	13-L	1/50~1/200(1/240~1/260)	85	65	7	163	131	500	510	16.5	-	M16
2HP (1.5kW)	13-S	1/5~1/40	85	65	7	163	131	480	490	16.5	-	M16
	13-L	1/50~1/100(1/125~1/260)	85	65	7	163	131	520	530	16.5	-	M16
	14-S	1/5~1/40	92.5	92.5	8	181	138	570	590	-	-	M16
3HP (2.2kW)	14-L	1/50~1/160(1/180~1/285)	92.5	92.5	8	181	138	605	620	-	-	M20
	14-S	1/5~1/40	92.5	92.5	8	181	138	610	630	-	-	M16
	14-L	1/50~1/120(1/160~1/285)	92.5	92.5	8	181	138	645	660	-	-	M20

unit: mm

馬力 Horse Power	型號 Model	減速比 Ratio	出力軸 Output Shaft										重量 Weight (KG)
			D	DB	S	W	T	U	LC	LD	LE	LF	
1/8HP (0.1kW)	09	1/5~1/100(1/120)	18	53	30	6	6	14.5	42	35	162	120	
	10-S	1/5~1/40	22	66	40	6	6	18.5	54	47	208	154	
	10-L	1/50~1/200(1/240)	22	66	40	6	6	18.5	54	47	208	154	
1/4HP (0.2kW)	09	1/5~1/50(1/60~1/120)	18	53	30	6	6	14.5	42	35	162	120	
	10-S	1/5~1/40	22	66	40	6	6	18.5	54	47	208	154	
	10-L	1/50~1/100(1/120~1/240)	22	66	40	6	6	18.5	54	47	208	154	
	11-S	1/5~1/40	28	75	45	8	7	24	59	52	224	165	
	11-L	1/45~1/200(1/220~1/260)	28	75	45	8	7	24	59	52	224	165	
1/2HP (0.4kW)	11-S	1/5~1/40	28	75	45	8	7	24	59	52	224	165	
	11-L	1/45~1/100(1/120~1/260)	28	75	45	8	7	24	59	52	224	165	
	12-S	1/5~1/40	32	85	55	10	8	27	69	62	262	193	
1HP (0.75kW)	12-L	1/50~1/200(1/225~1/250)	32	85	55	10	8	27	69	62	262	193	
	12-S	1/5~1/40	32	85	55	10	8	27	69	62	262	193	
	13-S	1/5~1/40	40	100	65	12	8	35	79	72	308	229	
	13-L	1/50~1/200(1/240~1/260)	40	100	65	12	8	35	79	72	308	229	
	13-S	1/5~1/40	40	100	65	12	8	35	79	72	308	229	
2HP (1.5kW)	13-L	1/50~1/100(1/125~1/260)	40	100	65	12	8	35	79	72	308	229	
	14-S	1/5~1/40	50	120	75	14	9	44.5	90	82	365	275	
	14-L	1/50~1/160(1/180~1/285)	50	120	75	14	9	44.5	90	82	365	275	
3HP (2.2kW)	14-S	1/5~1/40	50	120	75	14	9	44.5	90	82	365	275	
	14-L	1/50~1/120(1/160~1/285)	50	120	75	14	9	44.5	90	82	365	275	

注:

- 表中 () 內數字系表示輕荷重使用。
- 表中重量以配合三相 4P 馬達為主，其它單相、剎車、直流、特殊等馬達重量另訂。
- 表中 L 內數字以三相馬達為主，其它特殊馬達另訂。
- 如需特殊馬達規格，請洽本司業務。
- 以上數值若有變更，恕不另行通知。

NOTE:

- Values shown in paranthesis () are used for light loading.
- Weights shown in the above chart are based on 3-phase 4P motors, weights for single phase, brake, DC, or special motor shall be referred to specific values.
- Values shown in 'L' column are based on 3-phase motor, other special motor Refer to specific motor refer to specific values.
- For special motor specifications, please contact our business.
- Above specifications are subject to change without prior notice.

■ 同心軸馬達自裝式戟齒減速機
Motor-Driver Hypoid Gear Reducer(Concentric Shaft)

■ MODEL : SKB-SO / SKB-LO

SKB-LO

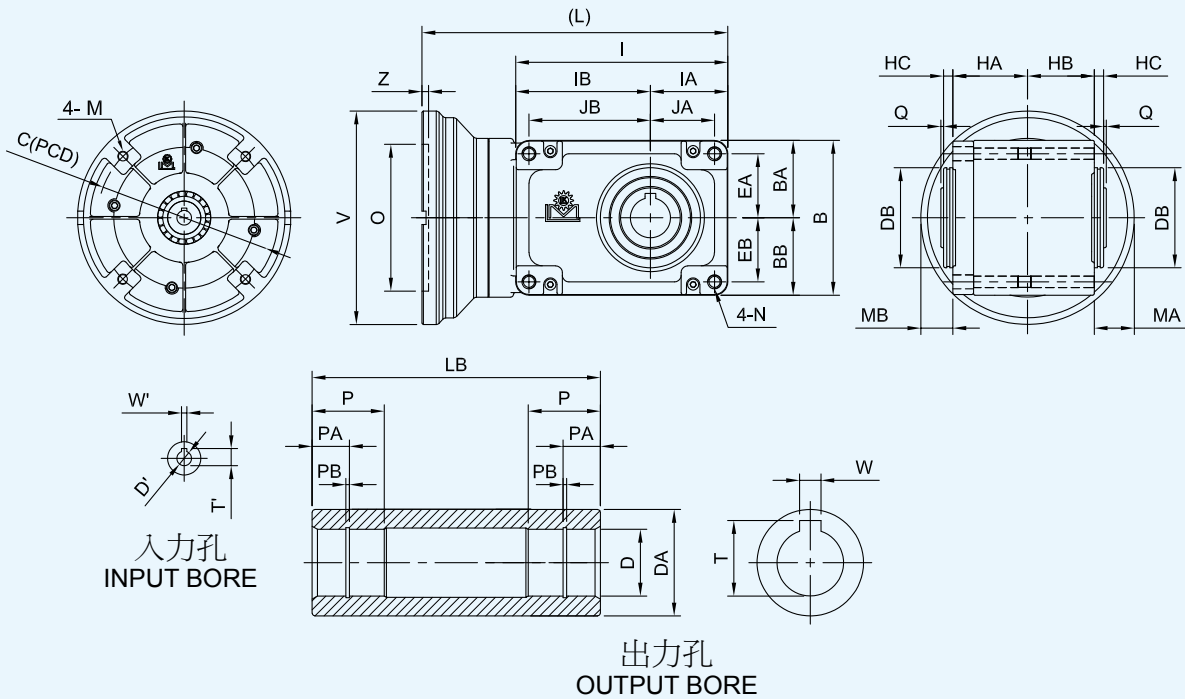

unit: mm

	馬力 Horse Power	V	O	Z	M	C	D'	W'	T'
輸入孔 Input Bore	1/8	160	110	5	M8	130	11	4	12.8
	1/4	160	110	5	M8	130	11	4	12.8
	1/2	160	110	5	M8	130	14	5	16.3
	1	200	130	5	M10	165	19	6	21.8
	2	200	130	5	M10	165	24	8	27.3
	3	250	180	5	M12	215	28	8	31.3

注：此表適用於 SKB-(S/L)O、SKB-(S/L)D 自裝式機種。
 NOTE: This table is suitable for SKB-(S/L)O、SKB-(S/L)D Motor-Driver models.

SMALL GEAR REDUCER SERIES



unit: mm

馬力 Horse Power	型號 Model	減速比 Ratio	JA	JB	I	IA	IB	EA	EB	B	BA
1/8HP (0.1kW)	09	1/5~1/100(1/120)	38.5	68.5	127	48.5	78.5	38.5	38.5	97	48.5
	10-S	1/5~1/40	43.5	76.5	139.5	53.5	86	43.5	43.5	107	53.5
	10-L	1/50~1/200(1/240)	43.5	95.5	158.5	53.5	105	43.5	43.5	107	53.5
1/4HP (0.2kW)	10-S	1/5~1/40	43.5	76.5	139.5	53.5	86	43.5	43.5	107	53.5
	10-L	1/50~1/100(1/120~1/240)	43.5	95.5	158.5	53.5	105	43.5	43.5	107	53.5
	11-S	1/5~1/40	48	91	159	58	101	48	48	116	58
1/2HP (0.4kW)	11-L	1/45~1/200(1/220~1/260)	46	110	180	58	122	46	46	116	58
	11-S	1/5~1/40	48	91	159	58	101	48	48	116	58
	11-L	1/45~1/100(1/120~1/260)	46	110	180	58	122	46	46	116	58
1HP (0.75kW)	12-S	1/5~1/40	56	105	185	68	117	56	56	136	68
	12-L	1/50~1/200(1/225~1/250)	54	140	222	68	154	54	54	136	68
	13-S	1/5~1/40	73	134	235	87	148	73	73	174	87
2HP (1.5kW)	13-L	1/50~1/100(1/120~1/250)	54	140	222	68	154	54	54	136	68
	13-S	1/5~1/40	73	134	235	87	148	73	73	174	87
	14-S	1/5~1/40	102	170	304	118	186	90	90	212	106
3HP (2.2kW)	14-L	1/50~1/160(1/180~1/285)	94	198	336	116	220	108	108	260	130
	14-S	1/5~1/40	102	170	304	118	186	90	90	212	106
	14-L	1/50~1/120(1/160~1/285)	94	198	336	116	220	108	108	260	130

unit: mm

馬力 Horse Power	型號 Model	減速比 Ratio	BB	HA	HB	HC	Q	L	MA	MB	N
1/8HP (0.1kW)	09	1/5~1/100(1/120)	48.5	47	31	7	2	184	49	33	M10
	10-S	1/5~1/40	53.5	50	50	7	2	214	30	30	M10
	10-L	1/50~1/200(1/240)	53.5	50	50	7	2	229	30	30	M10
1/4HP (0.2kW)	10-S	1/5~1/40	53.5	50	50	7	2	214	30	30	M10
	10-L	1/50~1/100(1/120~1/240)	53.5	50	50	7	2	229	30	30	M10
	11-S	1/5~1/40	58	56	50	7	2	229	30	24	M10
1/2HP (0.4kW)	11-L	1/45~1/200(1/220~1/260)	58	56	50	7	2	250	30	24	M12
	11-S	1/5~1/40	58	56	50	7	2	229	30	24	M10
	11-L	1/45~1/100(1/120~1/260)	58	56	50	7	2	250	30	24	M12
1HP (0.75kW)	12-S	1/5~1/40	68	67.5	56.5	7	2	258	23.5	12.5	M12
	12-L	1/50~1/200(1/225~1/250)	68	67.5	56.5	7	2	297	23.5	12.5	M16
	13-S	1/5~1/40	87	85	65	7	2	321	35	15	M16
2HP (1.5kW)	13-L	1/50~1/100(1/120~1/250)	87	85	65	7	2	361	35	15	M16
	13-S	1/5~1/40	87	85	65	7	2	331	35	15	M16
	14-S	1/5~1/40	106	92.5	92.5	8	2	407	7.5	7.5	M16
3HP (2.2kW)	14-L	1/50~1/160(1/180~1/285)	130	92.5	92.5	8	2	439	7.5	7.5	M20
	14-S	1/5~1/40	106	92.5	92.5	8	2	416	32.5	32.5	M16
	14-L	1/50~1/120(1/160~1/285)	130	92.5	92.5	8	2	448	32.5	32.5	M20

unit: mm

馬力 Horse Power	型號 Model	減速比 Ratio	出力孔 Output Bore									重量 Weight (KG)
			D	DA	DB	W	T	P	PA	PB	LB	
1/8HP (0.1kW)	09	1/5~1/100(1/120)	20	30	53	6	22.8	25	13	1.15	96	
	10-S	1/5~1/40	25	40	66	8	28.3	30	14	1.35	118	
	10-L	1/50~1/200(1/240)	25	40	66	8	28.3	30	14	1.35	118	
1/4HP (0.2kW)	10-S	1/5~1/40	25	40	66	8	28.3	30	14	1.35	118	
	10-L	1/50~1/100(1/120~1/240)	25	40	66	8	28.3	30	14	1.35	118	
	11-S	1/5~1/40	30	45	75	8	33.3	35	17	1.35	124	
1/2HP (0.4kW)	11-L	1/45~1/200(1/220~1/260)	30	45	75	8	33.3	35	17	1.35	124	
	11-S	1/5~1/40	30	45	75	8	33.3	35	17	1.35	124	
	11-L	1/45~1/100(1/120~1/260)	30	45	75	8	33.3	35	17	1.35	124	
1HP (0.75kW)	12-S	1/5~1/40	35	50	85	10	38.3	40	20	1.75	142	
	12-L	1/50~1/200(1/225~1/250)	35	50	85	10	38.3	40	20	1.75	142	
	13-S	1/5~1/40	35	50	85	10	38.3	40	20	1.75	142	
2HP (1.5kW)	13-L	1/50~1/100(1/120~1/250)	45	65	100	14	48.8	50	26	1.95	168	
	13-S	1/5~1/40	45	65	100	14	48.8	50	26	1.95	168	
	14-S	1/5~1/40	55	80	120	16	59.3	60	32	2.2	205	
3HP (2.2kW)	14-L	1/50~1/160(1/180~1/285)	55	80	120	16	59.3	60	32	2.2	205	
	14-S	1/5~1/40	55	80	120	16	59.3	60	32	2.2	205	

■ 同心軸馬達自裝式戟齒減速機
Motor-Driver Hypoid Gear Reducer(Concentric Shaft)

■ MODEL : SKB-SD / SKB-LD

SKB -D

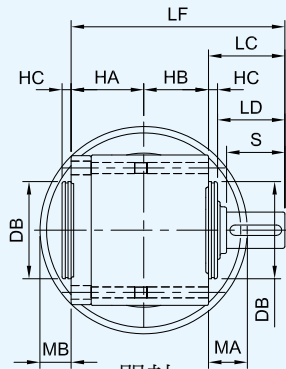
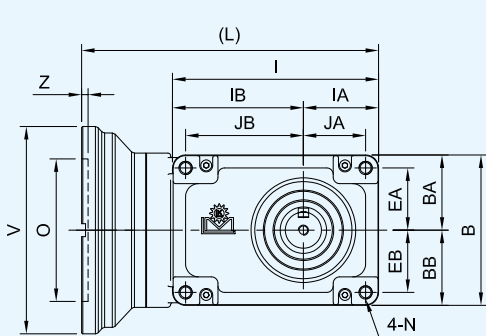

單軸
SINGLE SHAFT

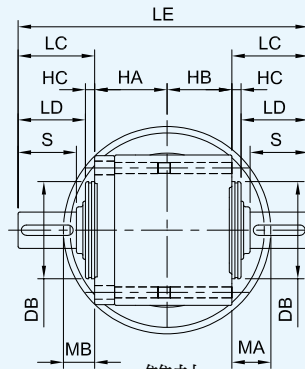

雙軸
DOUBLE SHAFT

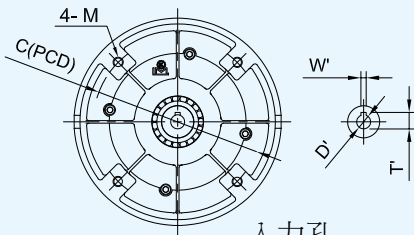

入力孔
INPUT BORE

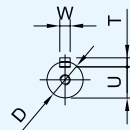

出力軸
OUTPUT SHAFT

unit: mm

	馬力 Horse Power	V	O	Z	M	C	D'	W'	T'
入力孔 Input Bore	1/8	160	110	5	M8	130	11	4	12.8
	1/4	160	110	5	M8	130	11	4	12.8
	1/2	160	110	5	M8	130	14	5	16.3
	1	200	130	5	M10	165	19	6	21.8
	2	200	130	5	M10	165	24	8	27.3
	3	250	180	5	M12	215	28	8	31.3

注：此表適用於 SKB-(S/L)O、SKB-(S/L)D 自裝式機種。
 NOTE: This table is suitable for SKB-(S/L)O、SKB-(S/L)D Motor-Driver models.

SMALL GEAR REDUCER SERIES



unit: mm

馬力 Horse Power	型號 Model	減速比 Ratio	JA	JB	I	IA	IB	EA	EB	B
1/8HP (0.1kW)	09	1/5~1/100(1/120)	38.5	68.5	127	48.5	78.5	38.5	38.5	97
	10-S	1/5~1/40	43.5	76.5	139.5	53.5	86	43.5	43.5	107
	10-L	1/50~1/200(1/240)	43.5	95.5	158.5	53.5	105	43.5	43.5	107
1/4HP (0.2kW)	10-S	1/5~1/40	43.5	76.5	139.5	53.5	86	43.5	43.5	107
	10-L	1/50~1/100(1/120~1/240)	43.5	95.5	158.5	53.5	105	43.5	43.5	107
	11-S	1/5~1/40	48	91	159	58	101	48	48	116
1/2HP (0.4kW)	11-L	1/45~1/200(1/220~1/260)	46	110	180	58	122	46	46	116
	11-S	1/5~1/40	48	91	159	58	101	48	48	116
	11-L	1/45~1/100(1/120~1/260)	46	110	180	58	122	46	46	116
1HP (0.75kW)	12-S	1/5~1/40	56	105	185	68	117	56	56	136
	12-L	1/50~1/200(1/225~1/250)	54	140	222	68	154	54	54	136
	12-S	1/5~1/40	56	105	185	68	117	56	56	136
2HP (1.5kW)	13-S	1/50~1/100(1/120~1/250)	54	140	222	68	154	54	54	136
	13-S	1/5~1/40	73	134	235	87	148	73	73	174
	13-L	1/50~1/200(1/240~1/260)	69	167	272	87	185	69	69	174
3HP (2.2kW)	13-S	1/5~1/40	73	134	235	87	148	73	73	174
	13-L	1/50~1/100(1/125~1/260)	69	167	272	87	185	69	69	174
	14-S	1/5~1/40	102	170	304	118	186	90	90	212
	14-L	1/50~1/160(1/180~1/285)	94	198	336	116	220	108	108	260
	14-S	1/5~1/40	102	170	304	118	186	90	90	212
	14-L	1/50~1/120(1/160~1/285)	94	198	336	116	220	108	108	260

unit: mm

馬力 Horse Power	型號 Model	減速比 Ratio	BA	BB	HA	HB	HC	L	MA	MB	N
1/8HP (0.1kW)	09	1/5~1/100(1/120)	48.5	48.5	47	31	7	184	49	33	M10
	10-S	1/5~1/40	53.5	53.5	50	50	7	214	30	30	M10
	10-L	1/50~1/200(1/240)	53.5	53.5	50	50	7	229	30	30	M10
1/4HP (0.2kW)	10-S	1/5~1/40	53.5	53.5	50	50	7	214	30	30	M10
	10-L	1/50~1/100(1/120~1/240)	53.5	53.5	50	50	7	229	30	30	M10
	11-S	1/5~1/40	58	58	56	50	7	229	30	24	M10
1/2HP (0.4kW)	11-L	1/45~1/200(1/220~1/260)	58	58	56	50	7	250	30	24	M12
	11-S	1/5~1/40	58	58	56	50	7	229	30	24	M10
	11-L	1/45~1/100(1/120~1/260)	58	58	56	50	7	250	30	24	M12
1HP (0.75kW)	12-S	1/5~1/40	68	68	67.5	56.5	7	258	23.5	12.5	M12
	12-L	1/50~1/200(1/225~1/250)	68	68	67.5	56.5	7	297	23.5	12.5	M16
	12-S	1/5~1/40	68	68	67.5	56.5	7	272	43.5	32.5	M12
2HP (1.5kW)	13-S	1/50~1/100(1/120~1/250)	68	68	67.5	56.5	7	311	43.5	32.5	M16
	13-S	1/5~1/40	87	87	85	65	7	321	35	15	M16
	13-L	1/50~1/200(1/240~1/260)	87	87	85	65	7	361	35	15	M16
3HP (2.2kW)	13-S	1/5~1/40	87	87	85	65	7	331	35	15	M16
	13-L	1/50~1/100(1/125~1/260)	87	87	85	65	7	371	35	15	M16
	14-S	1/5~1/40	106	106	92.5	92.5	8	407	7.5	7.5	M16
	14-L	1/50~1/160(1/180~1/285)	130	130	92.5	92.5	8	439	7.5	7.5	M20
	14-S	1/5~1/40	106	106	92.5	92.5	8	416	32.5	32.5	M16
	14-L	1/50~1/120(1/160~1/285)	130	130	92.5	92.5	8	448	32.5	32.5	M20

unit: mm

馬力 Horse Power	型號 Model	減速比 Ratio	出力軸 Output Shaft										重量 Weight (KG)
			D	DB	S	W	T	U	LC	LD	LE	LF	
1/8HP (0.1kW)	09	1/5~1/100(1/120)	18	53	30	6	6	14.5	42	35	162	120	
	10-S	1/5~1/40	22	66	40	6	6	18.5	54	47	208	154	
	10-L	1/50~1/200(1/240)	22	66	40	6	6	18.5	54	47	208	154	
1/4HP (0.2kW)	10-S	1/5~1/40	22	66	40	6	6	18.5	54	47	208	154	
	10-L	1/50~1/100(1/120~1/240)	22	66	40	6	6	18.5	54	47	208	154	
	11-S	1/5~1/40	28	75	45	8	7	24	59	52	224	165	
1/2HP (0.4kW)	11-L	1/45~1/200(1/220~1/260)	28	75	45	8	7	24	59	52	224	165	
	11-S	1/5~1/40	28	75	45	8	7	24	59	52	224	165	
	11-L	1/45~1/100(1/120~1/260)	28	75	45	8	7	24	59	52	224	165	
1HP (0.75kW)	12-S	1/5~1/40	32	85	55	10	8	27	69	62	262	193	
	12-L	1/50~1/200(1/225~1/250)	32	85	55	10	8	27	69	62	262	193	
	12-S	1/5~1/40	32	85	55	10	8	27	69	62	262	193	
2HP (1.5kW)	13-S	1/50~1/100(1/120~1/250)	32	85	55	10	8	27	69	62	262	193	
	13-S	1/5~1/40	40	100	65	12	8	35	79	72	308	229	
	13-L	1/50~1/200(1/240~1/260)	40	100	65	12	8	35	79	72	308	229	
3HP (2.2kW)	13-S	1/5~1/40	40	100	65	12	8	35	79	72	308	229	
	13-L	1/50~1/100(1/125~1/260)	40	100	65	12	8	35	79	72	308	229	
	14-S	1/5~1/40	50	120	75	14	9	44.5	90	82	365	275	
	14-L	1/50~1/160(1/180~1/285)	50	120	75	14	9	44.5	90	82	365	275	
	14-S	1/5~1/40	50	120	75	14	9	44.5	90	82	365	275	
	14-L	1/50~1/120(1/160~1/285)	50	120	75	14	9	44.5	90	82	365	275	

同心軸雙軸戟齒減速機

Double-Axle Hypoid Gear Reducer(Concentric Shaft)

MODEL : SKD-SO / SKD-LO

SKD -O

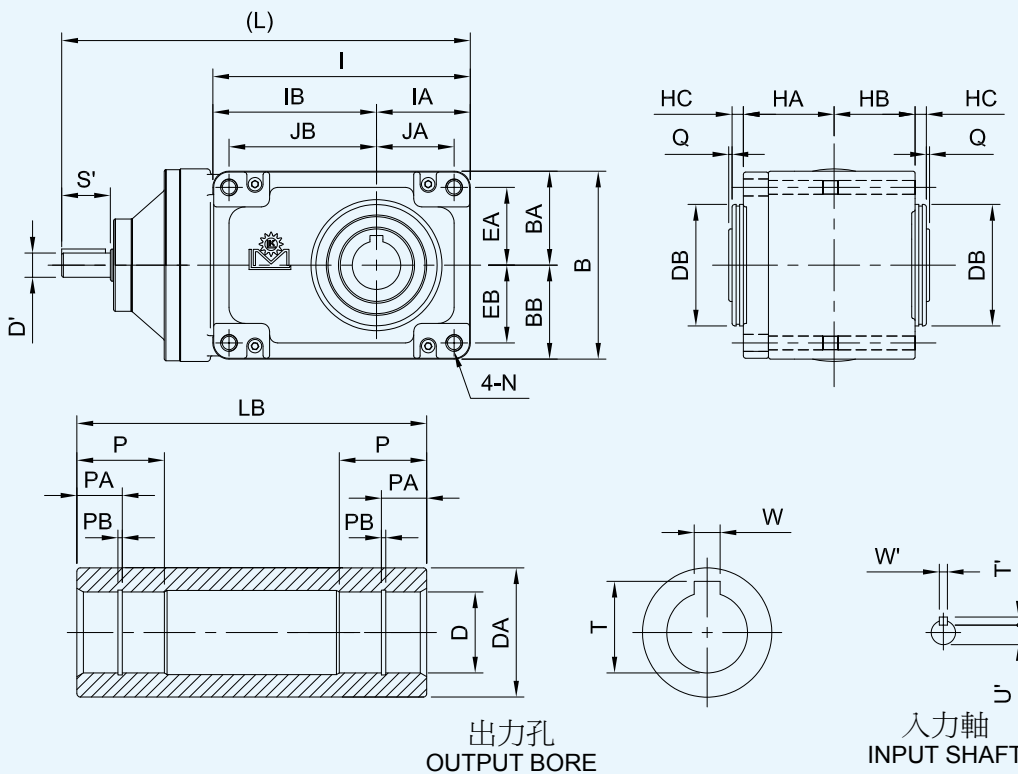

出力孔
OUTPUT BORE

入力軸
INPUT SHAFT

unit: mm

	馬力 Horse Power	D'	S'	W'	T'	U'
入力軸 Input Shaft	1/8	12	25	4	4	9.5
	1/4	12	25	4	4	9.5
	1/2	15	30	5	5	12
	1	20	35	6	6	16.5
	2	25	40	8	7	21
	3	30	45	8	7	26

注：此表適用於 SKD-(S/L)O、SKD-(S/L)D 雙軸式機種。
NOTE: This table is suitable for SKD-(S/L)O、SKD-(S/L)D Double-Axle models.

SMALL GEAR REDUCER SERIES



unit: mm

馬力 Horse Power	型號 Model	減速比 Ratio	JA	JB	I	IA	IB	EA	EB	B
1/8HP (0.1kW)	09	1/5~1/100(1/120)	38.5	68.5	127	48.5	78.5	38.5	38.5	97
	10-S	1/5~1/40	43.5	76.5	139.5	53.5	86	43.5	43.5	107
	10-L	1/50~1/200(1/240)	43.5	95.5	158.5	53.5	105	43.5	43.5	107
1/4HP (0.2kW)	10-S	1/5~1/40	43.5	76.5	139.5	53.5	86	43.5	43.5	107
	10-L	1/50~1/100(1/120~1/240)	43.5	95.5	158.5	53.5	105	43.5	43.5	107
	11-S	1/5~1/40	48	91	159	58	101	48	48	116
1/2HP (0.4kW)	11-L	1/45~1/200(1/220~1/260)	46	110	180	58	122	46	46	116
	11-S	1/5~1/40	48	91	159	58	101	48	48	116
	11-L	1/45~1/100(1/120~1/260)	46	110	180	58	122	46	46	116
1HP (0.75kW)	12-S	1/5~1/40	56	105	185	68	117	56	56	136
	12-L	1/50~1/200(1/225~1/250)	54	140	222	68	154	54	54	136
	12-S	1/5~1/40	56	105	185	68	117	56	56	136
1HP (0.75kW)	12-L	1/50~1/100(1/120~1/250)	54	140	222	68	154	54	54	136
	13-S	1/5~1/40	73	134	235	87	148	73	73	174
	13-L	1/50~1/200(1/240~1/260)	69	167	272	87	185	69	69	174
2HP (1.5kW)	13-S	1/5~1/40	73	134	235	87	148	73	73	174
	13-L	1/50~1/100(1/125~1/260)	69	167	272	87	185	69	69	174
	14-S	1/5~1/40	102	170	304	118	186	90	90	212
3HP (2.2kW)	14-L	1/50~1/160(1/180~1/285)	94	198	336	116	220	108	108	260
	14-S	1/5~1/40	102	170	304	118	186	90	90	212
	14-L	1/50~1/120(1/160~1/285)	94	198	336	116	220	108	108	260

unit: mm

馬力 Horse Power	型號 Model	減速比 Ratio	BA	BB	HA	HB	HC	Q	L	N
1/8HP (0.1kW)	09	1/5~1/100(1/120)	48.5	48.5	47	31	7	2	207	M10
	10-S	1/5~1/40	53.5	53.5	50	50	7	2	233	M10
	10-L	1/50~1/200(1/240)	53.5	53.5	50	50	7	2	247	M10
1/4HP (0.2kW)	10-S	1/5~1/40	53.5	53.5	50	50	7	2	233	M10
	10-L	1/50~1/100(1/120~1/240)	53.5	53.5	50	50	7	2	247	M10
	11-S	1/5~1/40	58	58	56	50	7	2	247	M10
1/2HP (0.4kW)	11-L	1/45~1/200(1/220~1/260)	58	58	56	50	7	2	268	M12
	11-S	1/5~1/40	58	58	56	50	7	2	252	M10
	11-L	1/45~1/100(1/120~1/260)	58	58	56	50	7	2	273	M12
1HP (0.75kW)	12-S	1/5~1/40	68	68	67.5	56.5	7	2	283	M12
	12-L	1/50~1/200(1/225~1/250)	68	68	67.5	56.5	7	2	322	M16
	12-S	1/5~1/40	68	68	67.5	56.5	7	2	302	M12
1HP (0.75kW)	12-L	1/50~1/100(1/120~1/250)	68	68	67.5	56.5	7	2	341	M16
	13-S	1/5~1/40	87	87	85	65	7	2	351	M16
	13-L	1/50~1/200(1/240~1/260)	87	87	85	65	7	2	391	M16
2HP (1.5kW)	13-S	1/5~1/40	87	87	85	65	7	2	366	M16
	13-L	1/50~1/100(1/125~1/260)	87	87	85	65	7	2	406	M16
	14-S	1/5~1/40	106	106	92.5	92.5	8	2	442	M16
3HP (2.2kW)	14-L	1/50~1/160(1/180~1/285)	130	130	92.5	92.5	8	2	474	M20
	14-S	1/5~1/40	106	106	92.5	92.5	8	2	458	M16
	14-L	1/50~1/120(1/160~1/285)	130	130	92.5	92.5	8	2	490	M20

unit: mm

馬力 Horse Power	型號 Model	減速比 Ratio	出力孔 Output Bore								重量 Weight (KG)
			D	DA	DB	W	T	P	PA	PB	
1/8HP (0.1kW)	09	1/5~1/100(1/120)	20	30	53	6	22.8	25	13	1.15	96
	10-S	1/5~1/40	25	40	66	8	28.3	30	14	1.35	118
	10-L	1/50~1/200(1/240)	25	40	66	8	28.3	30	14	1.35	118
1/4HP (0.2kW)	10-S	1/5~1/40	25	40	66	8	28.3	30	14	1.35	118
	10-L	1/50~1/100(1/120~1/240)	25	40	66	8	28.3	30	14	1.35	118
	11-S	1/5~1/40	30	45	75	8	33.3	35	17	1.35	124
1/2HP (0.4kW)	11-L	1/45~1/200(1/220~1/260)	30	45	75	8	33.3	35	17	1.35	124
	11-S	1/5~1/40	30	45	75	8	33.3	35	17	1.35	124
	11-L	1/45~1/100(1/120~1/260)	30	45	75	8	33.3	35	17	1.35	124
1HP (0.75kW)	12-S	1/5~1/40	35	50	85	10	38.3	40	20	1.75	142
	12-L	1/50~1/200(1/225~1/250)	35	50	85	10	38.3	40	20	1.75	142
	12-S	1/5~1/40	35	50	85	10	38.3	40	20	1.75	142
1HP (0.75kW)	12-L	1/50~1/100(1/120~1/250)	35	50	85	10	38.3	40	20	1.75	142
	13-S	1/5~1/40	45	65	100	14	48.8	50	26	1.95	168
	13-L	1/50~1/200(1/240~1/260)	45	65	100	14	48.8	50	26	1.95	168
2HP (1.5kW)	13-S	1/5~1/40	45	65	100	14	48.8	50	26	1.95	168
	13-L	1/50~1/100(1/125~1/260)	45	65	100	14	48.8	50	26	1.95	168
	14-S	1/5~1/40	55	80	120	16	59.3	60	32	2.2	205
3HP (2.2kW)	14-L	1/50~1/160(1/180~1/285)	55	80	120	16	59.3	60	32	2.2	205
	14-S	1/5~1/40	55	80	120	16	59.3	60	32	2.2	205
	14-L	1/50~1/120(1/160~1/285)	55	80	120	16	59.3	60	32	2.2	205

同心軸雙軸戟齒減速機

Double-Axle Hypoid Gear Reducer(Concentric Shaft)

MODEL : SKD-SD / SKD-LD

SKD -D

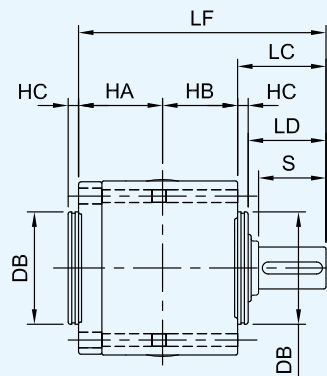
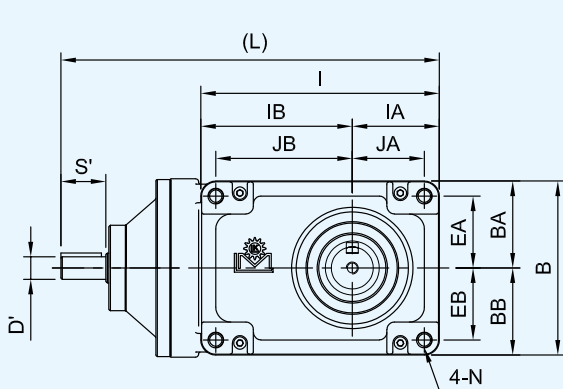

單軸
SINGLE SHAFT

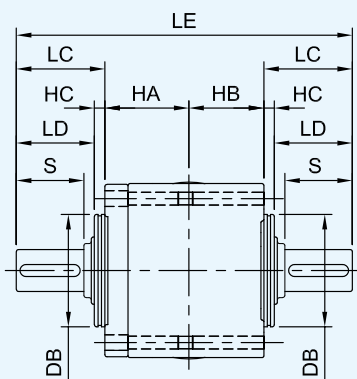

雙軸
DOUBLE SHAFT

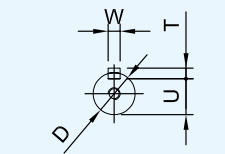

出力軸
OUTPUT SHAFT

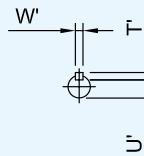

入力軸
INPUT SHAFT

unit: mm

	馬力 Horse Power	D'	S'	W'	T'	U'
入力軸 Input Shaft	1/8	12	25	4	4	9.5
	1/4	12	25	4	4	9.5
	1/2	15	30	5	5	12
	1	20	35	6	6	16.5
	2	25	40	8	7	21
	3	30	45	8	7	26

注：此表適用於 SKD-(S/L)O、SKD-(S/L)D 雙軸式機種。
NOTE: This table is suitable for SKD-(S/L)O、SKD-(S/L)D Double-Axle models.

SMALL GEAR REDUCER SERIES



unit: mm

馬力 Horse Power	型號 Model	減速比 Ratio	JA	JB	I	IA	IB	EA	EB
1/8HP (0.1kW)	09	1/5~1/100(1/120)	38.5	68.5	127	48.5	78.5	38.5	38.5
	10-S	1/5~1/40	43.5	76.5	139.5	53.5	86	43.5	43.5
	10-L	1/50~1/200(1/240)	43.5	95.5	158.5	53.5	105	43.5	43.5
1/4HP (0.2kW)	10-S	1/5~1/40	43.5	76.5	139.5	53.5	86	43.5	43.5
	10-L	1/50~1/100(1/120~1/240)	43.5	95.5	158.5	53.5	105	43.5	43.5
	11-S	1/5~1/40	48	91	159	58	101	48	48
1/2HP (0.4kW)	11-L	1/45~1/200(1/220~1/260)	46	110	180	58	122	46	46
	11-S	1/5~1/40	48	91	159	58	101	48	48
	11-L	1/45~1/100(1/120~1/260)	46	110	180	58	122	46	46
1HP (0.75kW)	12-S	1/5~1/40	56	105	185	68	117	56	56
	12-L	1/50~1/200(1/225~1/250)	54	140	222	68	154	54	54
	12-S	1/5~1/40	56	105	185	68	117	56	56
2HP (1.5kW)	12-L	1/50~1/100(1/120~1/250)	54	140	222	68	154	54	54
	13-S	1/5~1/40	73	134	235	87	148	73	73
	13-L	1/50~1/200(1/240~1/260)	69	167	272	87	185	69	69
3HP (2.2kW)	13-S	1/5~1/40	73	134	235	87	148	73	73
	13-L	1/50~1/100(1/125~1/260)	69	167	272	87	185	69	69
	14-S	1/5~1/40	102	170	304	118	186	90	90
2HP (1.5kW)	14-L	1/50~1/160(1/180~1/285)	94	198	336	116	220	108	108
	14-S	1/5~1/40	102	170	304	118	186	90	90
	14-L	1/50~1/120(1/160~1/285)	94	198	336	116	220	108	108

unit: mm

馬力 Horse Power	型號 Model	減速比 Ratio	B	BA	BB	HA	HB	HC	L	N
1/8HP (0.1kW)	09	1/5~1/100(1/120)	97	48.5	48.5	47	31	7	207	M10
	10-S	1/5~1/40	107	53.5	53.5	50	50	7	233	M10
	10-L	1/50~1/200(1/240)	107	53.5	53.5	50	50	7	247	M10
1/4HP (0.2kW)	10-S	1/5~1/40	107	53.5	53.5	50	50	7	233	M10
	10-L	1/50~1/100(1/120~1/240)	107	53.5	53.5	50	50	7	247	M10
	11-S	1/5~1/40	116	58	58	56	50	7	247	M10
1/2HP (0.4kW)	11-L	1/45~1/200(1/220~1/260)	116	58	58	56	50	7	268	M12
	11-S	1/5~1/40	116	58	58	56	50	7	252	M10
	11-L	1/45~1/100(1/120~1/260)	116	58	58	56	50	7	273	M12
1HP (0.75kW)	12-S	1/5~1/40	136	68	68	67.5	56.5	7	283	M12
	12-L	1/50~1/200(1/225~1/250)	136	68	68	67.5	56.5	7	322	M16
	12-S	1/5~1/40	136	68	68	67.5	56.5	7	302	M12
2HP (1.5kW)	12-L	1/50~1/100(1/120~1/250)	136	68	68	67.5	56.5	7	341	M16
	13-S	1/5~1/40	174	87	87	85	65	7	351	M16
	13-L	1/50~1/200(1/240~1/260)	174	87	87	85	65	7	391	M16
3HP (2.2kW)	13-S	1/5~1/40	174	87	87	85	65	7	366	M16
	13-L	1/50~1/100(1/125~1/260)	174	87	87	85	65	7	406	M16
	14-S	1/5~1/40	212	106	106	92.5	92.5	8	442	M16
2HP (1.5kW)	14-L	1/50~1/160(1/180~1/285)	260	130	130	92.5	92.5	8	474	M20
	14-S	1/5~1/40	212	106	106	92.5	92.5	8	458	M16
	14-L	1/50~1/120(1/160~1/285)	260	130	130	92.5	92.5	8	490	M20

unit: mm

馬力 Horse Power	型號 Model	減速比 Ratio	出力軸 Output Shaft										重量 Weight (KG)
			D	DB	S	W	T	U	LC	LD	LE	LF	
1/8HP (0.1kW)	09	1/5~1/100(1/120)	18	53	30	6	6	14.5	42	35	162	120	
	10-S	1/5~1/40	22	66	40	6	6	18.5	54	47	208	154	
	10-L	1/50~1/200(1/240)	22	66	40	6	6	18.5	54	47	208	154	
1/4HP (0.2kW)	10-S	1/5~1/40	22	66	40	6	6	18.5	54	47	208	154	
	10-L	1/50~1/100(1/120~1/240)	22	66	40	6	6	18.5	54	47	208	154	
	11-S	1/5~1/40	28	75	45	8	7	24	59	52	224	165	
1/2HP (0.4kW)	11-L	1/45~1/200(1/220~1/260)	28	75	45	8	7	24	59	52	224	165	
	11-S	1/5~1/40	28	75	45	8	7	24	59	52	224	165	
	11-L	1/45~1/100(1/120~1/260)	28	75	45	8	7	24	59	52	224	165	
1HP (0.75kW)	12-S	1/5~1/40	32	85	55	10	8	27	69	62	262	193	
	12-L	1/50~1/200(1/225~1/250)	32	85	55	10	8	27	69	62	262	193	
	12-S	1/5~1/40	32	85	55	10	8	27	69	62	262	193	
2HP (1.5kW)	12-L	1/50~1/100(1/120~1/250)	32	85	55	10	8	27	69	62	262	193	
	13-S	1/5~1/40	40	100	65	12	8	35	79	72	308	229	
	13-L	1/50~1/200(1/240~1/260)	40	100	65	12	8	35	79	72	308	229	
3HP (2.2kW)	13-S	1/5~1/40	40	100	65	12	8	35	79	72	308	229	
	13-L	1/50~1/100(1/125~1/260)	40	100	65	12	8	35	79	72	308	229	
	14-S	1/5~1/40	50	120	75	14	9	44.5	90	82	365	275	
2HP (1.5kW)	14-L	1/50~1/160(1/180~1/285)	50	120	75	14	9	44.5	90	82	365	275	
	14-S	1/5~1/40	50	120	75	14	9	44.5	90	82	365	275	
	14-L	1/50~1/120(1/160~1/285)	50	120	75	14	9	44.5	90	82	365	275	

■ 同心軸多速比蝸齒減速機

High Reduction Hypoid Gear Reducer(Concentric Shaft)

■ MODEL : SKL-SO / SKL-LO

SKL-LO

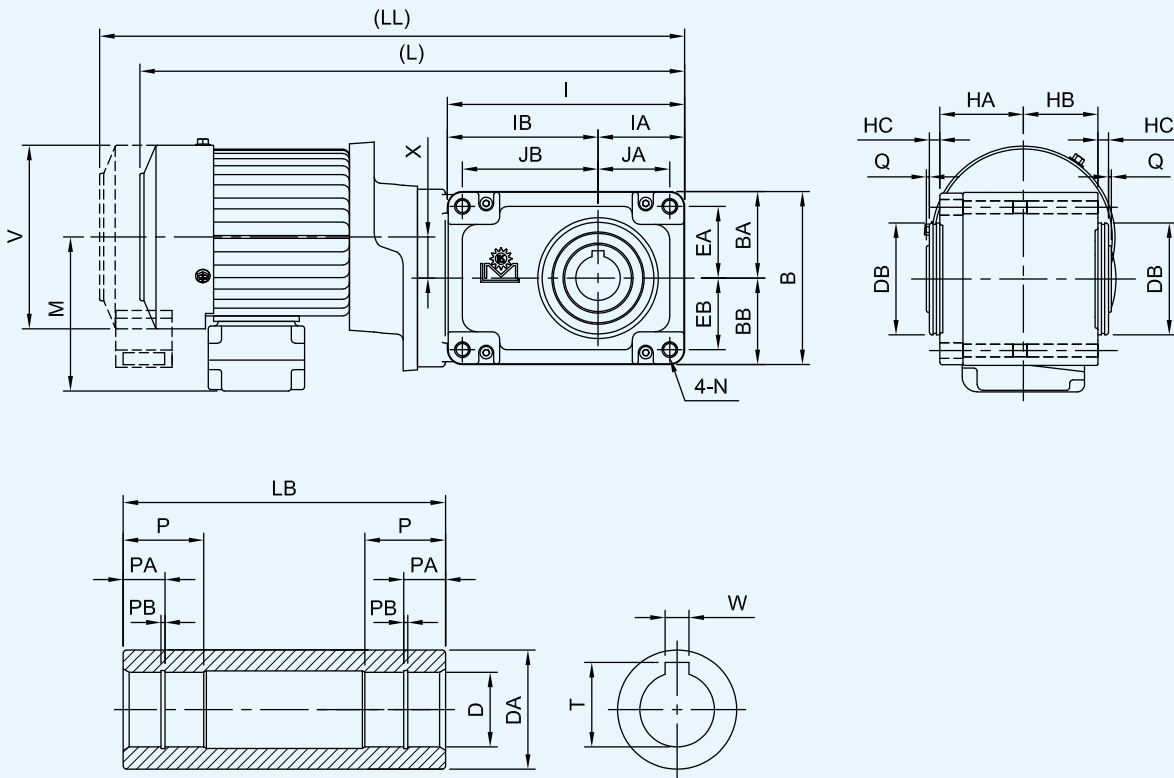

出力孔
OUTPUT BORE

SMALL GEAR REDUCER SERIES

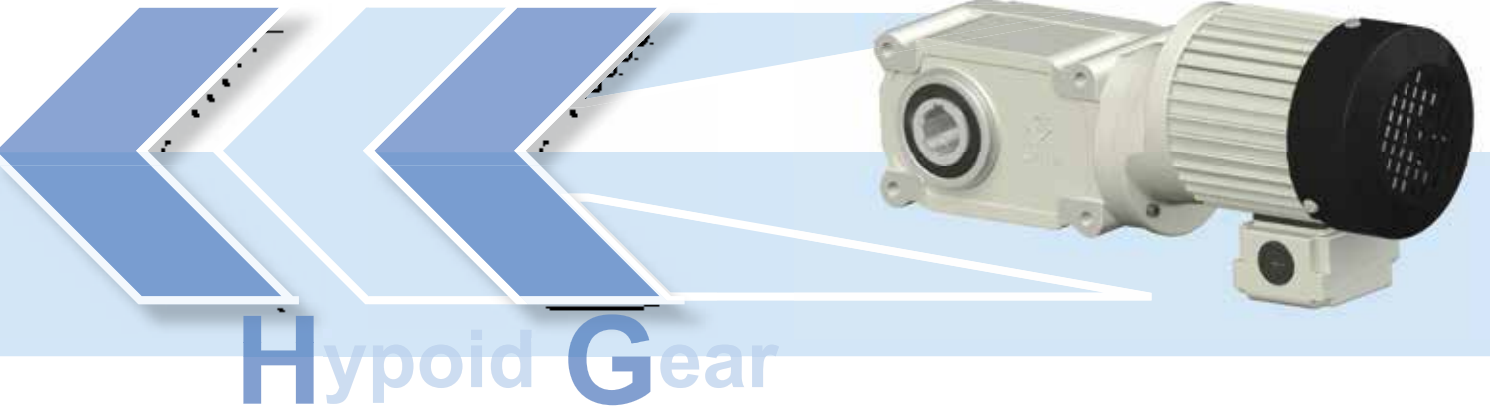

Hypoid Gear

最大容許扭力 Max. Permissible Torque					
型號 Model No.	10	11	12	13	14
扭力 Torque kg-m	10	20	40	75	110

unit: mm

馬力 Horse Power	型號 Model	減速比 Ratio	JA	JB	I	IA	IB	EA	EB	B	BA	BB
1/8HP (0.1kW)	10-S	1/100~1/400	43.5	76.5	139.5	53.5	86	43.5	43.5	107	53.5	53.5
	10-L	1/250~1/2500	43.5	95.5	158.5	53.5	105	43.5	43.5	107	53.5	53.5
	11-S	1/100~1/400	48	91	159	58	101	48	48	116	58	58
	11-L	1/250~1/2500	46	110	180	58	122	46	46	116	58	58
1/4HP (0.2kW)	12-S	1/100~1/400	56	105	185	68	117	56	56	136	68	68
	12-L	1/250~1/2500	54	140	222	68	154	54	54	136	68	68
1/2HP (0.4kW)	13-S	1/100~1/400	73	134	235	87	148	73	73	174	87	87
	13-L	1/250~1/2500	69	167	272	87	185	69	69	174	87	87
1HP (0.75kW)	14-S	1/100~1/400	102	170	304	118	186	90	90	212	106	106
	14-L	1/250~1/2500	94	198	336	116	220	108	108	260	130	130

unit: mm

馬力 Horse Power	型號 Model	減速比 Ratio	HA	HB	HC	Q	X	V	M	L	LL	N
1/8HP (0.1kW)	10-S	1/100~1/400	50	50	7	2	27.5	137	115	375	395	M10
	10-L	1/250~1/2500	50	50	7	2	27.5	137	115	385	405	M10
	11-S	1/100~1/400	56	50	7	2	27.5	137	115	385	405	M10
	11-L	1/250~1/2500	56	50	7	2	27.5	137	115	410	430	M12
1/4HP (0.2kW)	12-S	1/100~1/400	67.5	56.5	7	2	34	137	115	445	465	M12
	12-L	1/250~1/2500	67.5	56.5	7	2	34	137	115	485	505	M16
1/2HP (0.4kW)	13-S	1/100~1/400	85	65	7	2	42.5	151	120	505	510	M16
	13-L	1/250~1/2500	85	65	7	2	42.5	151	120	545	550	M16
1HP (0.75kW)	14-S	1/100~1/400	92.5	92.5	8	2	53	163	128	615	625	M16
	14-L	1/250~1/2500	92.5	92.5	8	2	53	163	128	650	660	M20

unit: mm

馬力 Horse Power	型號 Model	減速比 Ratio	出力孔 Output Bore									重量 Weight (KG)
			D	DA	DB	W	T	P	PA	PB	LB	
1/8HP (0.1kW)	10-S	1/100~1/400	25	40	66	8	28.3	30	14	1.35	118	
	10-L	1/250~1/2500	25	40	66	8	28.3	30	14	1.35	118	
	11-S	1/100~1/400	30	45	75	8	33.3	35	17	1.35	124	
	11-L	1/250~1/2500	30	45	75	8	33.3	35	17	1.35	124	
1/4HP (0.2kW)	12-S	1/100~1/400	35	50	85	10	38.3	40	20	1.75	142	
	12-L	1/250~1/2500	35	50	85	10	38.3	40	20	1.75	142	
1/2HP (0.4kW)	13-S	1/100~1/400	45	65	100	14	48.8	50	26	1.95	168	
	13-L	1/250~1/2500	45	65	100	14	48.8	50	26	1.95	168	
1HP (0.75kW)	14-S	1/100~1/400	55	80	120	16	59.3	60	32	2.2	205	
	14-L	1/250~1/2500	55	80	120	16	59.3	60	32	2.2	205	

- 注:
- 表中 () 內數字系表示輕荷重使用。
 - 表中重量以配合三相 4P 馬達為主，其它單相、剎車、直流、特殊等馬達重量另訂。
 - 表中 L 內數字以三相馬達為主，其它特殊馬達另訂。
 - 如需特殊馬達規格，請洽本司業務。
 - 以上數值若有變更，恕不另行通知。

- NOTE:
- Values shown in paranthesis () are used for light loading.
 - Weights shown in the above chart are based on 3-phase 4P motors, weights for single phase, brake, DC, or special motor shall be referred to specific values.
 - Values shown in 'L' column are based on 3-phase motor, other special motor Refer to specific motor refer to specific values.
 - For special motor specifications, please contact our business.
 - Above specifications are subject to change without prior notice.



■ 同心軸多速比戟齒減速機

High Reduction Hypoid Gear Reducer(Concentric Shaft)

■ MODEL : SKL-SD / SKL-LD

SKL -D

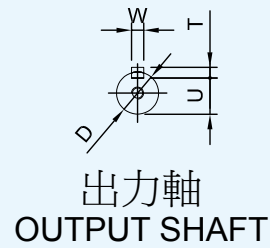
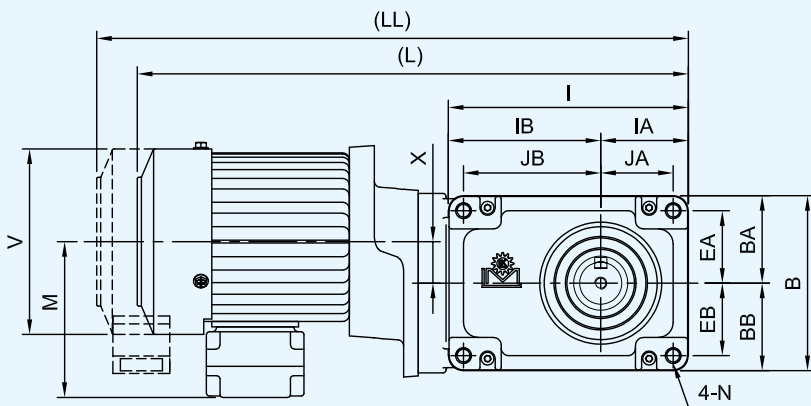

出力軸
OUTPUT SHAFT

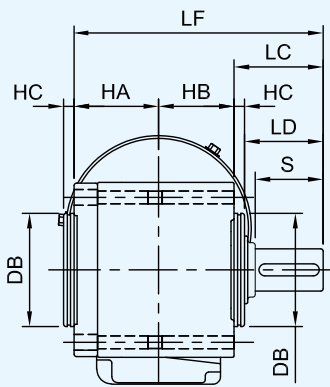

單軸
SINGLE SHAFT

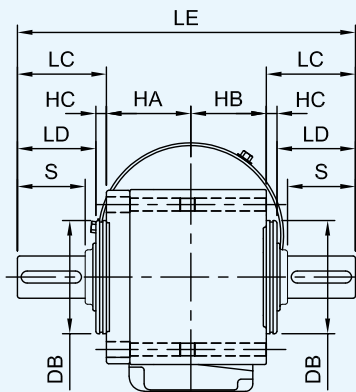

雙軸
DOUBLE SHAFT

SMALL GEAR REDUCER SERIES



最大容許扭力 Max. Permissible Torque					
型號 Model No.	10	11	12	13	14
扭力 Torque kg-m	10	20	40	75	110

unit: mm

馬力 Horse Power	型號 Model	減速比 Ratio	JA	JB	I	IA	IB	EA	EB	B	BA	BB
1/8HP (0.1kW)	10-S	1/100~1/400	43.5	76.5	139.5	53.5	86	43.5	43.5	107	53.5	53.5
	10-L	1/250~1/2500	43.5	95.5	158.5	53.5	105	43.5	43.5	107	53.5	53.5
	11-S	1/100~1/400	48	91	159	58	101	48	48	116	58	58
	11-L	1/250~1/2500	46	110	180	58	122	46	46	116	58	58
1/4HP (0.2kW)	12-S	1/100~1/400	56	105	185	68	117	56	56	136	68	68
	12-L	1/250~1/2500	54	140	222	68	154	54	54	136	68	68
1/2HP (0.4kW)	13-S	1/100~1/400	73	134	235	87	148	73	73	174	87	87
	13-L	1/250~1/2500	69	167	272	87	185	69	69	174	87	87
1HP (0.75kW)	14-S	1/100~1/400	102	170	304	118	186	90	90	212	106	106
	14-L	1/250~1/2500	94	198	336	116	220	108	108	260	130	130

unit: mm

馬力 Horse Power	型號 Model	減速比 Ratio	HA	HB	HC	X	V	M	L	LL	N
1/8HP (0.1kW)	10-S	1/100~1/400	50	50	7	27.5	137	115	375	395	M10
	10-L	1/250~1/2500	50	50	7	27.5	137	115	385	405	M10
	11-S	1/100~1/400	56	50	7	27.5	137	115	385	405	M10
	11-L	1/250~1/2500	56	50	7	27.5	137	115	410	430	M12
1/4HP (0.2kW)	12-S	1/100~1/400	67.5	56.5	7	34	137	115	445	465	M12
	12-L	1/250~1/2500	67.5	56.5	7	34	137	115	485	505	M16
1/2HP (0.4kW)	13-S	1/100~1/400	85	65	7	42.5	151	120	505	510	M16
	13-L	1/250~1/2500	85	65	7	42.5	151	120	545	550	M16
1HP (0.75kW)	14-S	1/100~1/400	92.5	92.5	8	53	163	128	615	625	M16
	14-L	1/250~1/2500	92.5	92.5	8	53	163	128	650	660	M20

unit: mm

馬力 Horse Power	型號 Model	減速比 Ratio	出力軸 Output Shaft										重量 Weight (KG)
			D	DB	S	W	T	U	LC	LD	LE	LF	
1/8HP (0.1kW)	10-S	1/100~1/400	22	66	40	6	6	18.5	54	47	208	154	
	10-L	1/250~1/2500	22	66	40	6	6	18.5	54	47	208	154	
	11-S	1/100~1/400	28	75	45	8	7	24	59	52	224	165	
	11-L	1/250~1/2500	28	75	45	8	7	24	59	52	224	165	
1/4HP (0.2kW)	12-S	1/100~1/400	32	85	55	10	8	27	69	62	262	193	
	12-L	1/250~1/2500	32	85	55	10	8	27	69	62	262	193	
1/2HP (0.4kW)	13-S	1/100~1/400	40	100	65	12	8	35	79	72	308	229	
	13-L	1/250~1/2500	40	100	65	12	8	35	79	72	308	229	
1HP (0.75kW)	14-S	1/100~1/400	50	120	75	14	9	44.5	90	82	365	275	
	14-L	1/250~1/2500	50	120	75	14	9	44.5	90	82	365	275	

注:

- 表中 () 內數字系表示輕荷重使用。
- 表中重量以配合三相 4P 馬達為主，其它單相、剎車、直流、特殊等馬達重量另訂。
- 表中 L 內數字以三相馬達為主，其它特殊馬達另訂。
- 如需特殊馬達規格，請洽本司業務。
- 以上數值若有變更，恕不另行通知。

NOTE:

- Values shown in paranthesis () are used for light loading.
- Weights shown in the above chart are based on 3-phase 4P motors, weights for single phase, brake, DC, or special motor shall be referred to specific values.
- Values shown in 'L' column are based on 3-phase motor, other special motor Refer to specific motor refer to specific values.
- For special motor specifications, please contact our business.
- Above specifications are subject to change without prior notice.

■ 同心軸多速馬達自裝式戟齒減速機

High Reduction Motor-Driver Hypoid Gear Reducer(Concentric Shaft)

■ MODEL : SKBL-SO / SKBL-LO

SKBL -O

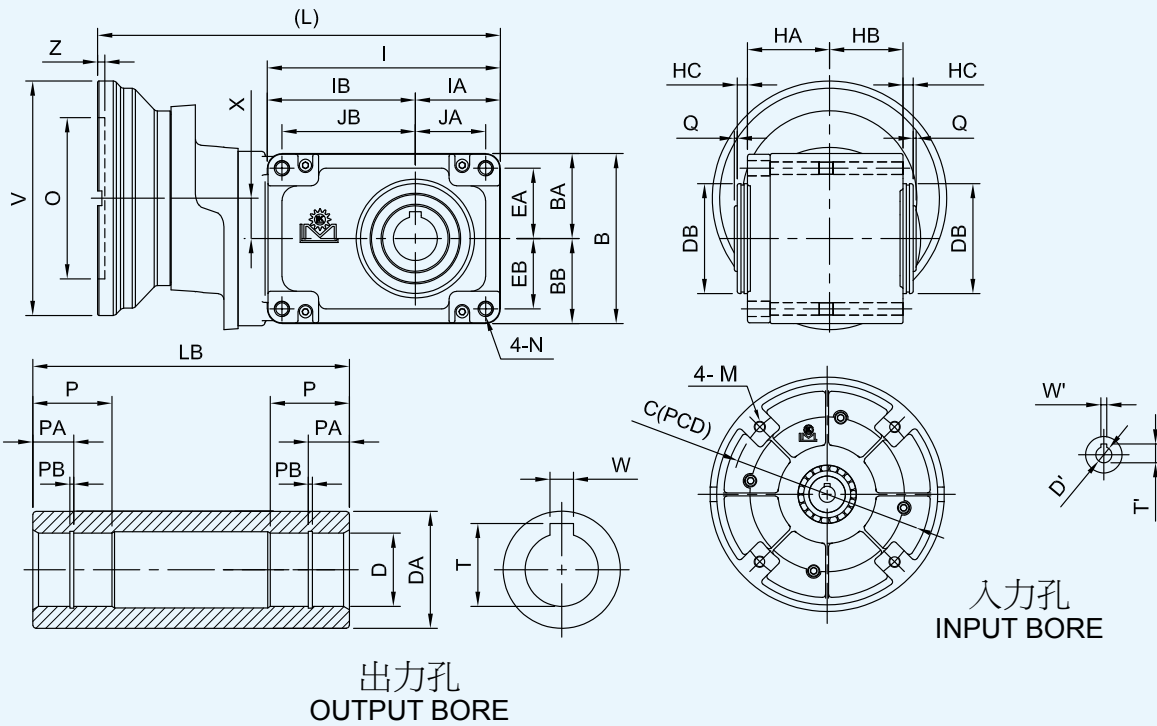

SMALL GEAR REDUCER SERIES

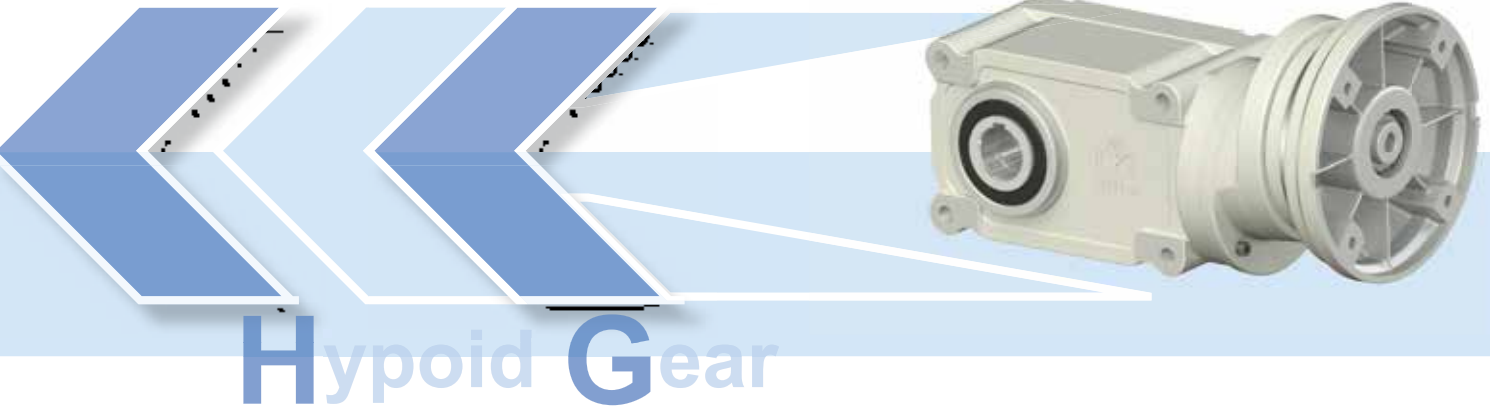

Hypoid Gear

unit: mm

最大容許扭力 Max. Permissible Torque					
型號 Model No.	10	11	12	13	14
扭力 Torque kg-m	10	20	40	75	110

入力孔 Input Bore	馬力 Horse Power	V	O	Z	M	C	D'	W'	T'
	1/8	160	110	5	M8	130	11	4	12.8
	1/4	160	110	5	M8	130	11	4	12.8
	1/2	160	110	5	M8	130	14	5	16.3
	1	200	130	5	M10	165	19	6	21.8

unit: mm

馬力 Horse Power	型號 Model	減速比 Ratio	JA	JB	I	IA	IB	EA	EB	B
1/8HP (0.1kW)	10-S	1/100~1/400	43.5	76.5	139.5	53.5	86	43.5	43.5	107
	10-L	1/250~1/2500	43.5	95.5	158.5	53.5	105	43.5	43.5	107
	11-S	1/100~1/400	48	91	159	58	101	48	48	116
	11-L	1/250~1/2500	46	110	180	58	122	46	46	116
1/4HP (0.2kW)	12-S	1/100~1/400	56	105	185	68	117	56	56	136
	12-L	1/250~1/2500	54	140	222	68	154	54	54	136
1/2HP (0.4kW)	13-S	1/100~1/400	73	134	235	87	148	73	73	174
	13-L	1/250~1/2500	69	167	272	87	185	69	69	174
1HP (0.75kW)	14-S	1/100~1/400	102	170	304	118	186	90	90	212
	14-L	1/250~1/2500	94	198	336	116	220	108	108	260

unit: mm

馬力 Horse Power	型號 Model	減速比 Ratio	BA	BB	HA	HB	HC	Q	X	L	N
1/8HP (0.1kW)	10-S	1/100~1/400	53.5	53.5	50	50	7	2	27.5	265	M10
	10-L	1/250~1/2500	53.5	53.5	50	50	7	2	27.5	280	M10
	11-S	1/100~1/400	58	58	56	50	7	2	27.5	280	M10
	11-L	1/250~1/2500	58	58	56	50	7	2	27.5	300	M12
1/4HP (0.2kW)	12-S	1/100~1/400	68	68	67.5	56.5	7	2	34	315	M12
	12-L	1/250~1/2500	68	68	67.5	56.5	7	2	34	355	M16
1/2HP (0.4kW)	13-S	1/100~1/400	87	87	85	65	7	2	42.5	370	M16
	13-L	1/250~1/2500	87	87	85	65	7	2	42.5	410	M16
1HP (0.75kW)	14-S	1/100~1/400	106	106	92.5	92.5	8	2	53	480	M16
	14-L	1/250~1/2500	130	130	92.5	92.5	8	2	53	510	M20

unit: mm

馬力 Horse Power	型號 Model	減速比 Ratio	出力孔 Output Bore									重量 Weight (KG)
			D	DA	DB	W	T	P	PA	PB	LB	
1/8HP (0.1kW)	10-S	1/100~1/400	25	40	66	8	28.3	30	14	1.35	118	
	10-L	1/250~1/2500	25	40	66	8	28.3	30	14	1.35	118	
	11-S	1/100~1/400	30	45	75	8	33.3	35	17	1.35	124	
	11-L	1/250~1/2500	30	45	75	8	33.3	35	17	1.35	124	
1/4HP (0.2kW)	12-S	1/100~1/400	35	50	85	10	38.3	40	20	1.75	142	
	12-L	1/250~1/2500	35	50	85	10	38.3	40	20	1.75	142	
1/2HP (0.4kW)	13-S	1/100~1/400	45	65	100	14	48.8	50	26	1.95	168	
	13-L	1/250~1/2500	45	65	100	14	48.8	50	26	1.95	168	
1HP (0.75kW)	14-S	1/100~1/400	55	80	120	16	59.3	60	32	2.2	205	
	14-L	1/250~1/2500	55	80	120	16	59.3	60	32	2.2	205	

注:

1. 多速比減速機以定轉速設計, 請參考齒箱最大容許扭力。
2. 以上數值若有變更, 恕不另行通知。

NOTE:

1. This multistage gear reducer is designed to rotate at fixed speed. Please refer to the maximum allowable torque of the gear box.
2. Above specifications are subject to change without prior notice.

■ 同心軸多速馬達自裝式戟齒減速機

High Reduction Motor-Driver Hypoid Gear Reducer(Concentric Shaft)

■ MODEL : SKBL-SD / SKBL-LD

SKBL -D

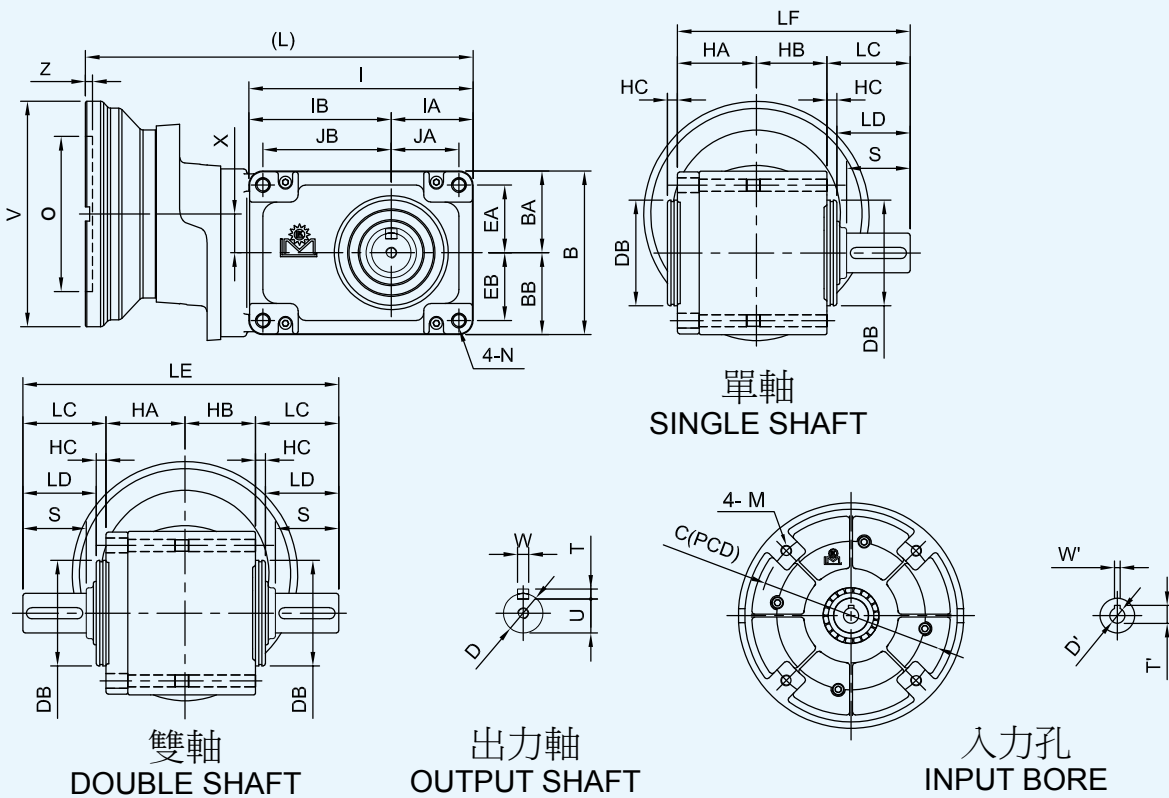

單軸
SINGLE SHAFT

雙軸
DOUBLE SHAFT

出力軸
OUTPUT SHAFT

入力孔
INPUT BORE

SMALL GEAR REDUCER SERIES



Hypoid Gear

unit: mm

最大容許扭力 Max. Permissible Torque					
型號 Model No.	10	11	12	13	14
扭力 Torque kg-m	10	20	40	75	110

入力孔 Input Bore	馬力 Horse Power	V	O	Z	M	C	D'	W'	T'
	1/8	160	110	5	M8	130	11	4	12.8
	1/4	160	110	5	M8	130	11	4	12.8
	1/2	160	110	5	M8	130	14	5	16.3
	1	200	130	5	M10	165	19	6	21.8

unit: mm

馬力 Horse Power	型號 Model	減速比 Ratio	JA	JB	I	IA	IB	EA	EB	B
1/8HP (0.1kW)	10-S	1/100~1/400	43.5	76.5	139.5	53.5	86	43.5	43.5	107
	10-L	1/250~1/2500	43.5	95.5	158.5	53.5	105	43.5	43.5	107
	11-S	1/100~1/400	48	91	159	58	101	48	48	116
	11-L	1/250~1/2500	46	110	180	58	122	46	46	116
1/4HP (0.2kW)	12-S	1/100~1/400	56	105	185	68	117	56	56	136
	12-L	1/250~1/2500	54	140	222	68	154	54	54	136
1/2HP (0.4kW)	13-S	1/100~1/400	73	134	235	87	148	73	73	174
	13-L	1/250~1/2500	69	167	272	87	185	69	69	174
1HP (0.75kW)	14-S	1/100~1/400	102	170	304	118	186	90	90	212
	14-L	1/250~1/2500	94	198	336	116	220	108	108	260

unit: mm

馬力 Horse Power	型號 Model	減速比 Ratio	BA	BB	HA	HB	HC	X	L	N
1/8HP (0.1kW)	10-S	1/100~1/400	53.5	53.5	50	50	7	27.5	265	M10
	10-L	1/250~1/2500	53.5	53.5	50	50	7	27.5	280	M10
	11-S	1/100~1/400	58	58	56	50	7	27.5	280	M10
	11-L	1/250~1/2500	58	58	56	50	7	27.5	300	M12
1/4HP (0.2kW)	12-S	1/100~1/400	68	68	67.5	56.5	7	34	315	M12
	12-L	1/250~1/2500	68	68	67.5	56.5	7	34	355	M16
1/2HP (0.4kW)	13-S	1/100~1/400	87	87	85	65	7	42.5	370	M16
	13-L	1/250~1/2500	87	87	85	65	7	42.5	410	M16
1HP (0.75kW)	14-S	1/100~1/400	106	106	92.5	92.5	8	53	480	M16
	14-L	1/250~1/2500	130	130	92.5	92.5	8	53	510	M20

unit: mm

馬力 Horse Power	型號 Model	減速比 Ratio	出力軸 Output Shaft										重量 Weight (KG)
			D	DB	S	W	T	U	LC	LD	LE	LF	
1/8HP (0.1kW)	10-S	1/100~1/400	22	66	40	6	6	18.5	54	47	208	154	
	10-L	1/250~1/2500	22	66	40	6	6	18.5	54	47	208	154	
	11-S	1/100~1/400	28	75	45	8	7	24	59	52	224	165	
	11-L	1/250~1/2500	28	75	45	8	7	24	59	52	224	165	
1/4HP (0.2kW)	12-S	1/100~1/400	32	85	55	10	8	27	69	62	262	193	
	12-L	1/250~1/2500	32	85	55	10	8	27	69	62	262	193	
1/2HP (0.4kW)	13-S	1/100~1/400	40	100	65	12	8	35	79	72	308	229	
	13-L	1/250~1/2500	40	100	65	12	8	35	79	72	308	229	
1HP (0.75kW)	14-S	1/100~1/400	50	120	75	14	9	44.5	90	82	365	275	
	14-L	1/250~1/2500	50	120	75	14	9	44.5	90	82	365	275	

注：
1. 多速比減速機以定轉速設計，請參考齒箱最大容許扭力。
2. 以上數值若有變更，恕不另行通知。

NOTE:
1. This multistage gear reducer is designed to rotate at fixed speed. Please refer to the maximum allowable torque of the gear box.
2. Above specifications are subject to change without prior notice.

■ 同心軸多速雙軸戟齒減速機

High Reduction Double-Axle Hypoid Gear Reducer(Concentric Shaft)

■ MODEL : SKDL-SO / SKDL-LO

SKDL -O

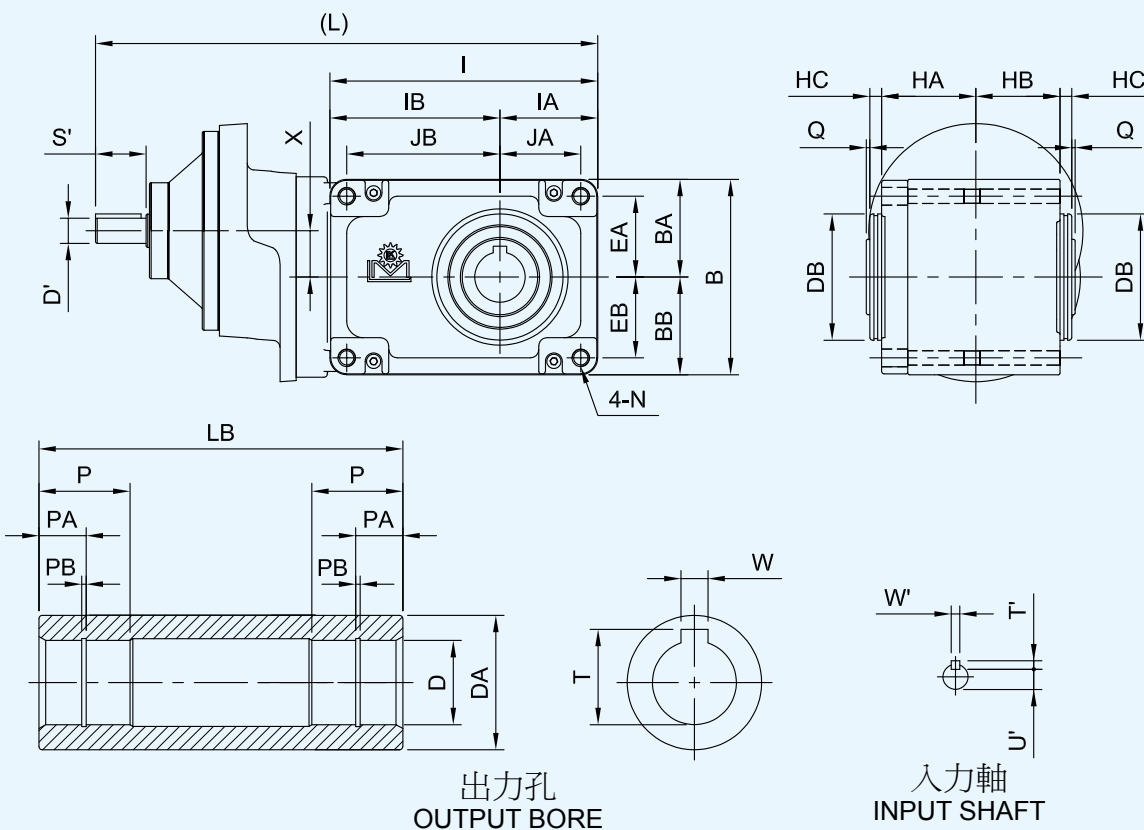

SMALL GEAR REDUCER SERIES



Hypoid Gear

unit: mm

最大容許扭力 Max. Permissible Torque					
型號 Model No.	10	11	12	13	14
扭力 Torque kg-m	10	20	40	75	110

入力軸 Input Shaft	馬力 Horse Power	D'	S'	W'	T'	U'
	1/8	12	25	4	4	9.5
	1/4	12	25	4	4	9.5
	1/2	15	30	5	5	12
	1	20	35	6	6	16.5

unit: mm

馬力 Horse Power	型號 Model	減速比 Ratio	JA	JB	I	IA	IB	EA	EB	B
1/8HP (0.1kW)	10-S	1/100~1/400	43.5	76.5	139.5	53.5	86	43.5	43.5	107
	10-L	1/250~1/2500	43.5	95.5	158.5	53.5	105	43.5	43.5	107
	11-S	1/100~1/400	48	91	159	58	101	48	48	116
	11-L	1/250~1/2500	46	110	180	58	122	46	46	116
1/4HP (0.2kW)	12-S	1/100~1/400	56	105	185	68	117	56	56	136
	12-L	1/250~1/2500	54	140	222	68	154	54	54	136
1/2HP (0.4kW)	13-S	1/100~1/400	73	134	235	87	148	73	73	174
	13-L	1/250~1/2500	69	167	272	87	185	69	69	174
1HP (0.75kW)	14-S	1/100~1/400	102	170	304	118	186	90	90	212
	14-L	1/250~1/2500	94	198	336	116	220	108	108	260

unit: mm

馬力 Horse Power	型號 Model	減速比 Ratio	BA	BB	HA	HB	HC	Q	X	L	N
1/8HP (0.1kW)	10-S	1/100~1/400	53.5	53.5	50	50	7	2	27.5	285	M10
	10-L	1/250~1/2500	53.5	53.5	50	50	7	2	27.5	295	M10
	11-S	1/100~1/400	58	58	56	50	7	2	27.5	295	M10
	11-L	1/250~1/2500	58	58	56	50	7	2	27.5	320	M12
1/4HP (0.2kW)	12-S	1/100~1/400	68	68	67.5	56.5	7	2	34	335	M12
	12-L	1/250~1/2500	68	68	67.5	56.5	7	2	34	375	M16
1/2HP (0.4kW)	13-S	1/100~1/400	87	87	85	65	7	2	42.5	395	M16
	13-L	1/250~1/2500	87	87	85	65	7	2	42.5	435	M16
1HP (0.75kW)	14-S	1/100~1/400	106	106	92.5	92.5	8	2	53	510	M16
	14-L	1/250~1/2500	130	130	92.5	92.5	8	2	53	540	M20

unit: mm

馬力 Horse Power	型號 Model	減速比 Ratio	出力孔 Output Bore									重量 Weight (KG)
			D	DA	DB	W	T	P	PA	PB	LB	
1/8HP (0.1kW)	10-S	1/100~1/400	25	40	66	8	28.3	30	14	1.35	118	
	10-L	1/250~1/2500	25	40	66	8	28.3	30	14	1.35	118	
	11-S	1/100~1/400	30	45	75	8	33.3	35	17	1.35	124	
	11-L	1/250~1/2500	30	45	75	8	33.3	35	17	1.35	124	
1/4HP (0.2kW)	12-S	1/100~1/400	35	50	85	10	38.3	40	20	1.75	142	
	12-L	1/250~1/2500	35	50	85	10	38.3	40	20	1.75	142	
1/2HP (0.4kW)	13-S	1/100~1/400	45	65	100	14	48.8	50	26	1.95	168	
	13-L	1/250~1/2500	45	65	100	14	48.8	50	26	1.95	168	
1HP (0.75kW)	14-S	1/100~1/400	55	80	120	16	59.3	60	32	2.2	205	
	14-L	1/250~1/2500	55	80	120	16	59.3	60	32	2.2	205	

注:

1. 多速比減速機以定轉速設計, 請參考齒箱最大容許扭力。

2. 以上數值若有變更, 恕不另行通知。

NOTE:

1. This multistage gear reducer is designed to rotate at fixed speed. Please refer to the maximum allowable torque of the gear box.

2. Above specifications are subject to change without prior notice.

■ 同心軸多速雙軸戟齒減速機

High Reduction Double-Axle Hypoid Gear Reducer(Concentric Shaft)

■ MODEL : SKDL-SD / SKDL-LD

SKDL -D

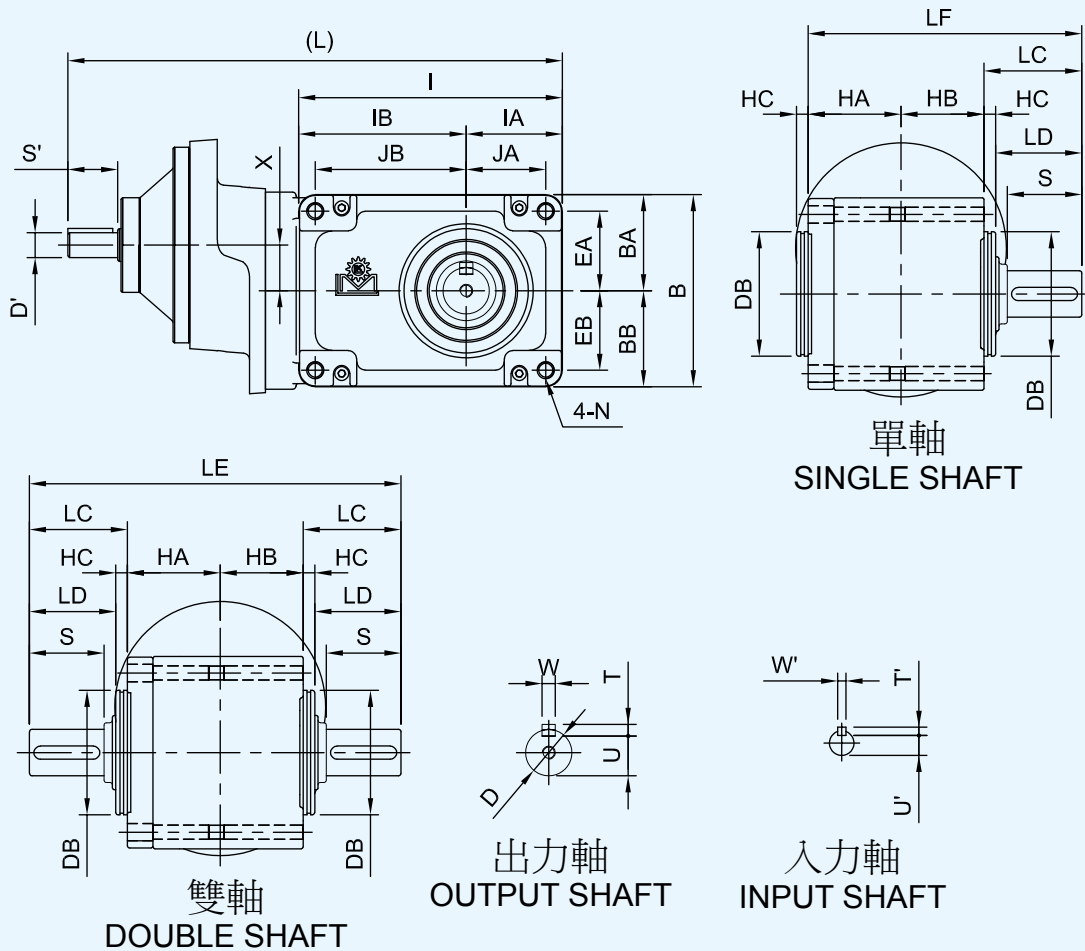

SMALL GEAR REDUCER SERIES



Hypoid Gear

unit: mm

最大容許扭力 Max. Permissible Torque					
型號 Model No.	10	11	12	13	14
扭力 Torque kg-m	10	20	40	75	110

入力軸 Input Shaft	馬力 Horse Power	D'	S'	W'	T'	U'
	1/8	12	25	4	4	9.5
	1/4	12	25	4	4	9.5
	1/2	15	30	5	5	12
	1	20	35	6	6	16.5

unit: mm

馬力 Horse Power	型號 Model	減速比 Ratio	JA	JB	I	IA	IB	EA	EB	B
1/8HP (0.1kW)	10-S	1/100~1/400	43.5	76.5	139.5	53.5	86	43.5	43.5	107
	10-L	1/250~1/2500	43.5	95.5	158.5	53.5	105	43.5	43.5	107
	11-S	1/100~1/400	48	91	159	58	101	48	48	116
	11-L	1/250~1/2500	46	110	180	58	122	46	46	116
1/4HP (0.2kW)	12-S	1/100~1/400	56	105	185	68	117	56	56	136
	12-L	1/250~1/2500	54	140	222	68	154	54	54	136
1/2HP (0.4kW)	13-S	1/100~1/400	73	134	235	87	148	73	73	174
	13-L	1/250~1/2500	69	167	272	87	185	69	69	174
1HP (0.75kW)	14-S	1/100~1/400	102	170	304	118	186	90	90	212
	14-L	1/250~1/2500	94	198	336	116	220	108	108	260

unit: mm

馬力 Horse Power	型號 Model	減速比 Ratio	BA	BB	HA	HB	HC	X	L	N
1/8HP (0.1kW)	10-S	1/100~1/400	53.5	53.5	50	50	7	27.5	285	M10
	10-L	1/250~1/2500	53.5	53.5	50	50	7	27.5	295	M10
	11-S	1/100~1/400	58	58	56	50	7	27.5	295	M10
	11-L	1/250~1/2500	58	58	56	50	7	27.5	320	M12
1/4HP (0.2kW)	12-S	1/100~1/400	68	68	67.5	56.5	7	34	335	M12
	12-L	1/250~1/2500	68	68	67.5	56.5	7	34	375	M16
1/2HP (0.4kW)	13-S	1/100~1/400	87	87	85	65	7	42.5	395	M16
	13-L	1/250~1/2500	87	87	85	65	7	42.5	435	M16
1HP (0.75kW)	14-S	1/100~1/400	106	106	92.5	92.5	8	53	510	M16
	14-L	1/250~1/2500	130	130	92.5	92.5	8	53	540	M20

unit: mm

馬力 Horse Power	型號 Model	減速比 Ratio	出力軸 Output Shaft										重量 Weight (KG)
			D	DB	S	W	T	U	LC	LD	LE	LF	
1/8HP (0.1kW)	10-S	1/100~1/400	22	66	40	6	6	18.5	54	47	208	154	
	10-L	1/250~1/2500	22	66	40	6	6	18.5	54	47	208	154	
	11-S	1/100~1/400	28	75	45	8	7	24	59	52	224	165	
	11-L	1/250~1/2500	28	75	45	8	7	24	59	52	224	165	
1/4HP (0.2kW)	12-S	1/100~1/400	32	85	55	10	8	27	69	62	262	193	
	12-L	1/250~1/2500	32	85	55	10	8	27	69	62	262	193	
1/2HP (0.4kW)	13-S	1/100~1/400	40	100	65	12	8	35	79	72	308	229	
	13-L	1/250~1/2500	40	100	65	12	8	35	79	72	308	229	
1HP (0.75kW)	14-S	1/100~1/400	50	120	75	14	9	44.5	90	82	365	275	
	14-L	1/250~1/2500	50	120	75	14	9	44.5	90	82	365	275	

注：
1. 多速比減速機以定轉速設計，請參考齒箱最大容許扭力。
2. 以上數值若有變更，恕不另行通知。

NOTE：
1. This multistage gear reducer is designed to rotate at fixed speed. Please refer to the maximum allowable torque of the gear box.
2. Above specifications are subject to change without prior notice.

MEMO

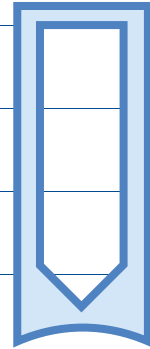

A series of horizontal blue lines for writing notes, spanning the width of the page.

A series of horizontal blue lines for writing notes, located on the left side of the bottom section.



同心軸齒蝸減速機 Gear Worm Reducer (Concentric Shaft)

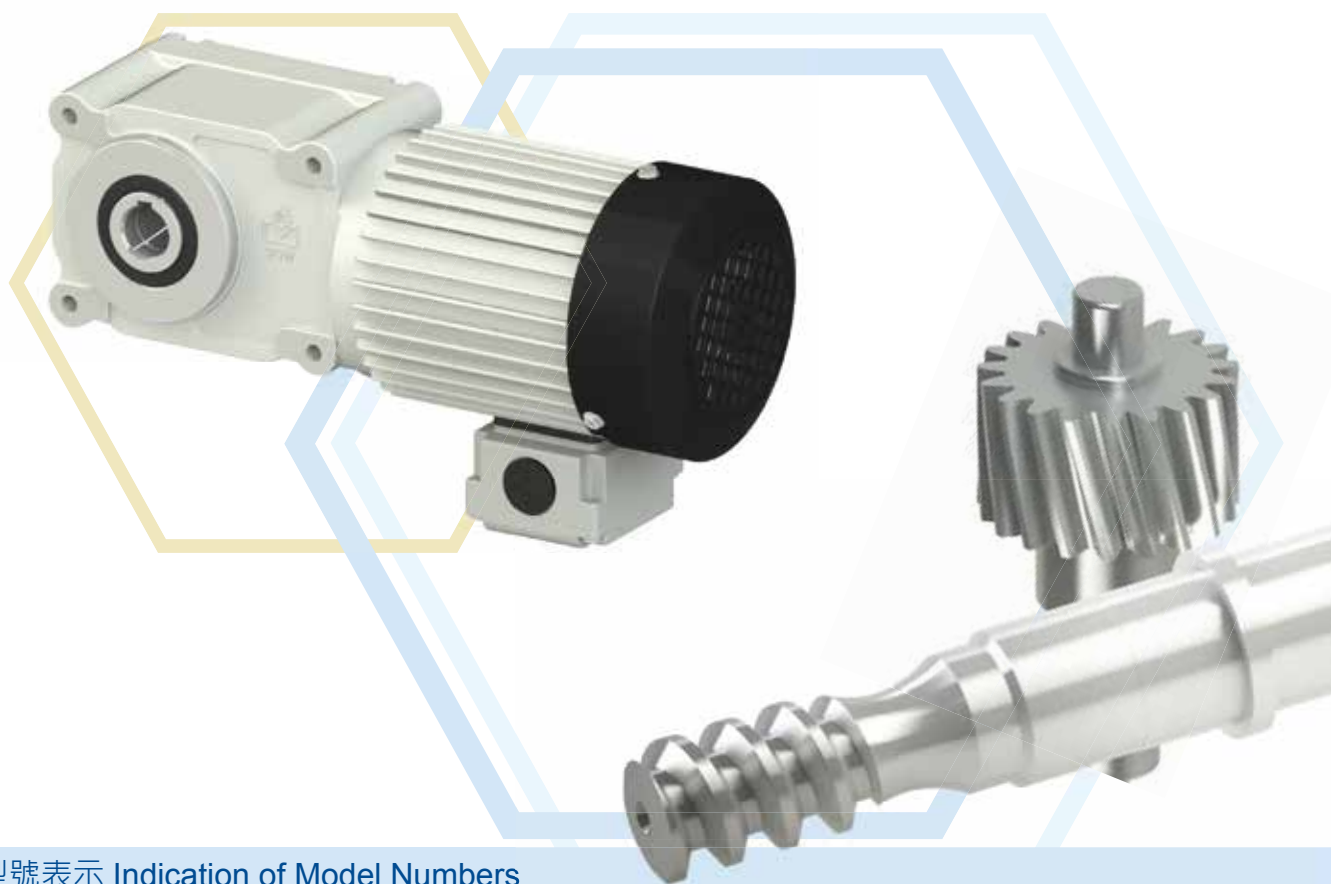















機種型號表示 Indication of Model Numbers

SGW	□	10	O	1/8	A	1/5
機型 Type SGW	機種 Type	型號 Model	出力軸表示 Output	馬力 Horse Power	馬達 Motor	減速比 Ratio
	□: 無 None B: 自裝式 Motor-Driver D: 雙軸式 Double-Axle L: 多速比 High Reduction BL: 多速比自裝式 High Reduction Motor-Driver DL: 多速比雙軸式 High Reduction Double-Axle	09 10 11 12 13 14	O: 中空軸 Hollow Shaft D: 實心軸 Solid Shaft	60W 1/8 HP 1/4 HP 1/2 HP 1 HP 2 HP 3 HP	A: 三相 3-Phase B: 剎車 Brake C: 特殊 Special S: 單相 Single Phase	1/80 ~ 1/300 ※

※ 表中減速比以公稱速比，如需實際速比，請另告知。The reduction ration in the table are nominal ratios. Please contact us if your need actual ratios.

產品樣式選擇 Selection Of Type

	SGW □ - O	SGW □ - D
	中空軸式 Solid Shaft	實心軸式 Hollow Shaft
<p>□</p> <p>標準型 Standard</p>		
<p>B</p> <p>自裝式 Motor Driver</p>	<p>SGW-O</p> 	<p>SGW-D</p> 
<p>D</p> <p>雙軸式 Double Axle</p>	<p>SGWB-O</p> 	<p>SGWB-D</p> 
<p>L</p> <p>多速比 High Reduction</p>	<p>SGWD-O</p> 	<p>SGWD-D</p> 
<p>BL</p> <p>多速比自裝式 High Reduction Motor Driver</p>	<p>SGWL-O</p> 	<p>SGWL-D</p> 
<p>DL</p> <p>多速比雙軸式 High Reduction Double Axle</p>	<p>SGWBL-O</p> 	<p>SGWBL-D</p> 
	<p>SGWDL-O</p> 	<p>SGWDL-D</p> 

■ 減速機安裝方向
Reducer Installation Direction

■ MODEL : SGW

代號 Code	示意圖 Schematic Diagram
F1	
F2	
F3	

代號 Code	示意圖 Schematic Diagram
F4	
F5	

■ 減速機線盒方向
Reducer Terminal Box Direction

代號 Code	示意圖 Schematic Diagram
盒上 UP	
盒左 LEFT	

代號 Code	示意圖 Schematic Diagram
盒下 DOWN	
盒右 RIGHT	

■ 同心軸齒蝸減速機
Gear Worm Reducer(Concentric Shaft)

■ MODEL : SGW-O

SGW-O

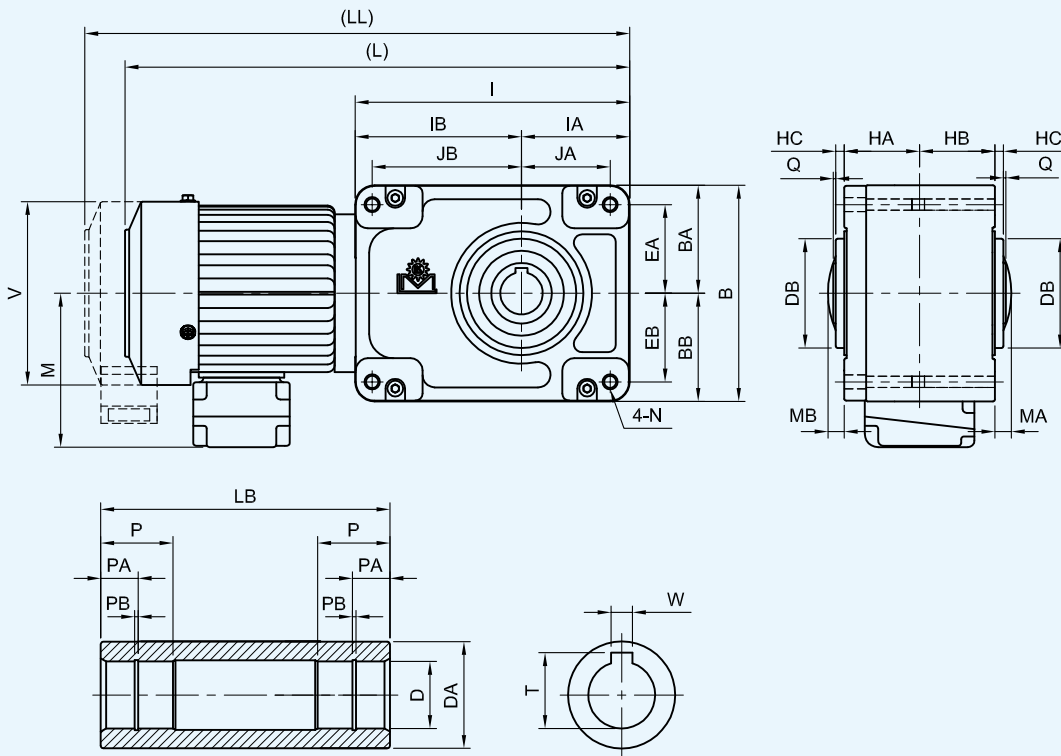

出力孔
OUTPUT BORE

SMALL GEAR REDUCER SERIES



最大容許扭力 Max. Permissible Torque						
型號 Model No.	09	10	11	12	13	14
扭力 Torque kg-m	5	10	20	40	75	110

unit: mm

馬力 Horse Power	型號 Model	減速比 Ratio	JA	JB	I	IA	IB	EA	EB	B	BA	BB
60W	09	1/10~1/290	38	70	128	48	80	38	38	96	48	48
1/8HP (0.1kW)	09	1/10~1/175	38	70	128	48	80	38	38	96	48	48
	10	1/20~1/240	47	88	159	59	100	47	47	118	59	59
1/4HP (0.2kW)	10	1/20~1/240	47	88	159	59	100	47	47	118	59	59
	11	1/20~1/290	58	106	187	70	117	58	58	140	70	70
1/2HP (0.4kW)	11	1/20~1/170	58	106	187	70	117	58	58	140	70	70
	12	1/20~1/300	73	123	226	89	137	73	73	178	89	89
1HP (0.75kW)	12	1/20~1/180	73	123	226	89	137	73	73	178	89	89
	13	1/10~1/310	88	150	278	108	170	88	88	216	108	108
2HP (1.5kW)	13	1/10~1/185	88	150	278	108	170	88	88	216	108	108
	14	1/10~1/200	105	182	337	130	207	105	105	260	130	130
3HP (2.2kW)	14	1/10~1/160	105	182	337	130	207	105	105	260	130	130

unit: mm

馬力 Horse Power	型號 Model	減速比 Ratio	HA	HB	HC	Q	V	M	L	LL	MA	MB	N
60W	09	1/10~1/290	46.5	33.5	6	2	123	108	315	330	28	15	M8
1/8HP (0.1kW)	09	1/10~1/175	46.5	33.5	6	2	123	108	315	330	28	15	M8
	10	1/20~1/240	50	50	7	2	137	115	340	360	18.5	18.5	M10
1/4HP (0.2kW)	10	1/20~1/240	50	50	7	2	137	115	340	360	18.5	18.5	M10
	11	1/20~1/290	59	47	7	2	137	115	385	405	21.5	9.5	M10
1/2HP (0.4kW)	11	1/20~1/170	59	47	7	2	137	115	400	420	21.5	9.5	M10
	12	1/20~1/300	69	55	7	2	151	121	430	435	20.5	6.5	M12
1HP (0.75kW)	12	1/20~1/180	69	55	7	2	151	121	455	460	20.5	6.5	M12
	13	1/10~1/310	85	65	7	2	163	131	505	515	16.5	-	M16
2HP (1.5kW)	13	1/10~1/185	85	65	7	2	163	131	525	535	16.5	-	M16
	14	1/10~1/200	101	80	10	2	181	138	605	620	10.5	-	M20
3HP (2.2kW)	14	1/10~1/160	101	80	10	2	181	138	645	660	10.5	-	M20

unit: mm

馬力 Horse Power	型號 Model	減速比 Ratio	出力孔 Output Bore									重量 Weight (KG)
			D	DA	DB	W	T	P	PA	PB	LB	
60W	09	1/10~1/290	20	30	70	6	22.8	25	13	1.15	96	
1/8HP (0.1kW)	09	1/10~1/175	20	30	70	6	22.8	25	13	1.15	96	
	10	1/20~1/240	25	40	90	8	28.3	30	14	1.35	118	
1/4HP (0.2kW)	10	1/20~1/240	25	40	90	8	28.3	30	14	1.35	118	
	11	1/20~1/290	30	45	90	8	33.3	35	17	1.35	124	
1/2HP (0.4kW)	11	1/20~1/170	30	45	90	8	33.3	35	17	1.35	124	
	12	1/20~1/300	35	50	90	10	38.3	40	20	1.75	142	
1HP (0.75kW)	12	1/20~1/180	35	50	90	10	38.3	40	20	1.75	142	
	13	1/10~1/310	45	65	100	14	48.8	50	26	1.95	168	
2HP (1.5kW)	13	1/10~1/185	45	65	100	14	48.8	50	26	1.95	168	
	14	1/10~1/200	55	80	140	16	59.3	60	32	2.2	205	
3HP (2.2kW)	14	1/10~1/160	55	80	140	16	59.3	60	32	2.2	205	

注:

- 表中 () 內數字系表示輕荷重使用。
- 表中重量以配合三相 4P 馬達為主，其它單相、剎車、直流、特殊等馬達重量另訂。
- 表中 L 內數字以三相馬達為主，其它特殊馬達另訂。
- 如需特殊馬達規格，請洽本司業務。
- 以上數值若有變更，恕不另行通知。

NOTE:

- Values shown in paranthesis () are used for light loading.
- Weights shown in the above chart are based on 3-phase 4P motors, weights for single phase, brake, DC, or special motor shall be referred to specific values.
- Values shown in 'L' column are based on 3-phase motor, other special motor Refer to specific motor refer to specific values.
- For special motor specifications, please contact our business.
- Above specifications are subject to change without prior notice.

■ 同心軸齒蝸減速機
Gear Worm Reducer(Concentric Shaft)

■ MODEL : SGW-D

SGW-D

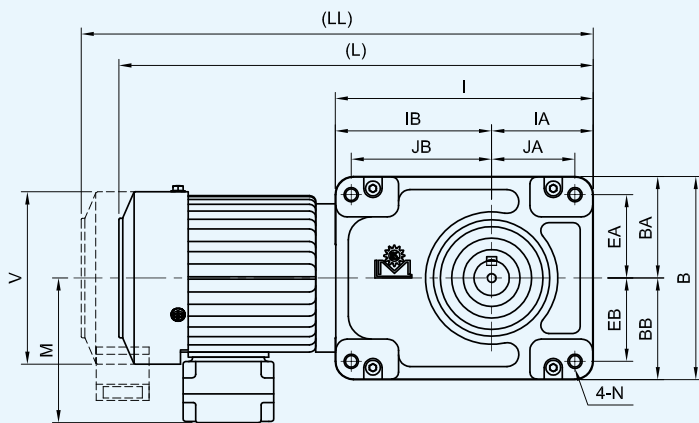

出力軸螺絲孔 Output Shaft Screw Hole	
型號 Model	螺絲規格 Screw Specifications
09	M6
10	M6
11	M8
12	M10
13	M12
14	M16

注：SGW 系列通用。
NOTE: Common for SGW series.

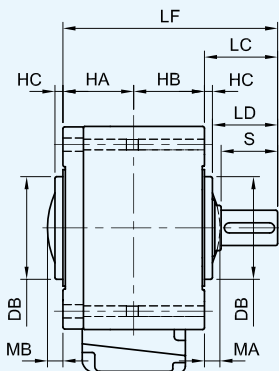

單軸
SINGLE SHAFT

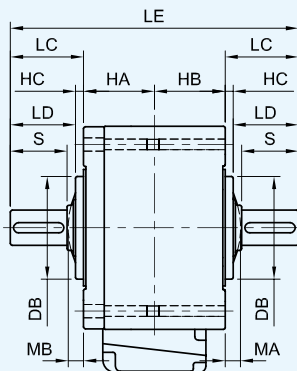

雙軸
DOUBLE SHAFT

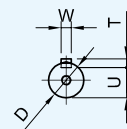

出力軸
OUTPUT SHAFT

SMALL GEAR REDUCER SERIES



Gear Worm

最大容許扭力 Max. Permissible Torque						
型號 Model No.	09	10	11	12	13	14
扭力 Torque kg-m	5	10	20	40	75	110

unit: mm

馬力 Horse Power	型號 Model	減速比 Ratio	JA	JB	I	IA	IB	EA	EB	B	BA	BB
60W	09	1/10~1/290	38	70	128	48	80	38	38	96	48	48
1/8HP (0.1kW)	09	1/10~1/175	38	70	128	48	80	38	38	96	48	48
	10	1/20~1/240	47	88	159	59	100	47	47	118	59	59
1/4HP (0.2kW)	10	1/20~1/240	47	88	159	59	100	47	47	118	59	59
	11	1/20~1/290	58	106	187	70	117	58	58	140	70	70
1/2HP (0.4kW)	11	1/20~1/170	58	106	187	70	117	58	58	140	70	70
	12	1/20~1/300	73	123	226	89	137	73	73	178	89	89
1HP (0.75kW)	12	1/20~1/180	73	123	226	89	137	73	73	178	89	89
	13	1/10~1/310	88	150	278	108	170	88	88	216	108	108
2HP (1.5kW)	13	1/10~1/185	88	150	278	108	170	88	88	216	108	108
	14	1/10~1/200	105	182	337	130	207	105	105	260	130	130
3HP (2.2kW)	14	1/10~1/160	105	182	337	130	207	105	105	260	130	130

unit: mm

馬力 Horse Power	型號 Model	減速比 Ratio	HA	HB	HC	V	M	L	LL	MA	MB	N
60W	09	1/10~1/290	46.5	33.5	6	123	108	315	330	28	15	M8
1/8HP (0.1kW)	09	1/10~1/175	46.5	33.5	6	123	108	315	330	28	15	M8
	10	1/20~1/240	50	50	7	137	115	340	360	18.5	18.5	M10
1/4HP (0.2kW)	10	1/20~1/240	50	50	7	137	115	340	360	18.5	18.5	M10
	11	1/20~1/290	59	47	7	137	115	385	405	21.5	9.5	M10
1/2HP (0.4kW)	11	1/20~1/170	59	47	7	137	115	400	420	21.5	9.5	M10
	12	1/20~1/300	69	55	7	151	121	430	435	20.5	6.5	M12
1HP (0.75kW)	12	1/20~1/180	69	55	7	151	121	455	460	20.5	6.5	M12
	13	1/10~1/310	85	65	7	163	131	505	515	16.5	-	M16
2HP (1.5kW)	13	1/10~1/185	85	65	7	163	131	525	535	16.5	-	M16
	14	1/10~1/200	101	80	10	181	138	605	620	10.5	-	M20
3HP (2.2kW)	14	1/10~1/160	101	80	10	181	138	645	660	10.5	-	M20

unit: mm

馬力 Horse Power	型號 Model	減速比 Ratio	出力軸 Output Shaft										重量 Weight (KG)
			D	DB	S	W	T	U	LC	LD	LE	LF	
60W	09	1/10~1/290	18	70	30	6	6	14.5	41	35	162	121	
1/8HP (0.1kW)	09	1/10~1/175	18	70	30	6	6	14.5	41	35	162	121	
	10	1/20~1/240	22	90	40	6	6	18.5	54	47	208	154	
1/4HP (0.2kW)	10	1/20~1/240	22	90	40	6	6	18.5	54	47	208	154	
	11	1/20~1/290	28	90	45	8	7	24	59	52	224	165	
1/2HP (0.4kW)	11	1/20~1/170	28	90	45	8	7	24	59	52	224	165	
	12	1/20~1/300	32	90	55	10	8	27	69	62	262	193	
1HP (0.75kW)	12	1/20~1/180	32	90	55	10	8	27	69	62	262	193	
	13	1/10~1/310	40	100	65	12	8	35	79	72	308	229	
2HP (1.5kW)	13	1/10~1/185	40	100	65	12	8	35	79	72	308	229	
	14	1/10~1/200	50	140	75	14	9	44.5	92	82	365	273	
3HP (2.2kW)	14	1/10~1/160	50	140	75	14	9	44.5	92	82	365	273	

注:

- 表中 () 內數字系表示輕荷重使用。
- 表中重量以配合三相 4P 馬達為主，其它單相、剎車、直流、特殊等馬達重量另訂。
- 表中 L 內數字以三相馬達為主，其它特殊馬達另訂。
- 如需特殊馬達規格，請洽本司業務。
- 以上數值若有變更，恕不另行通知。

NOTE:

- Values shown in paranthesis () are used for light loading.
- Weights shown in the above chart are based on 3-phase 4P motors, weights for single phase, brake, DC, or special motor shall be referred to specific values.
- Values shown in 'L' column are based on 3-phase motor, other special motor Refer to specific motor refet to specific values.
- For special motor specifications, please contact our business.
- Above specifications are subject to change without prior notice.

■ 同心軸馬達自裝式齒蝸減速機
Motor-Driver Gear Worm Reducer(Concentric Shaft)

■ MODEL : SGWB-O

SGWB-O

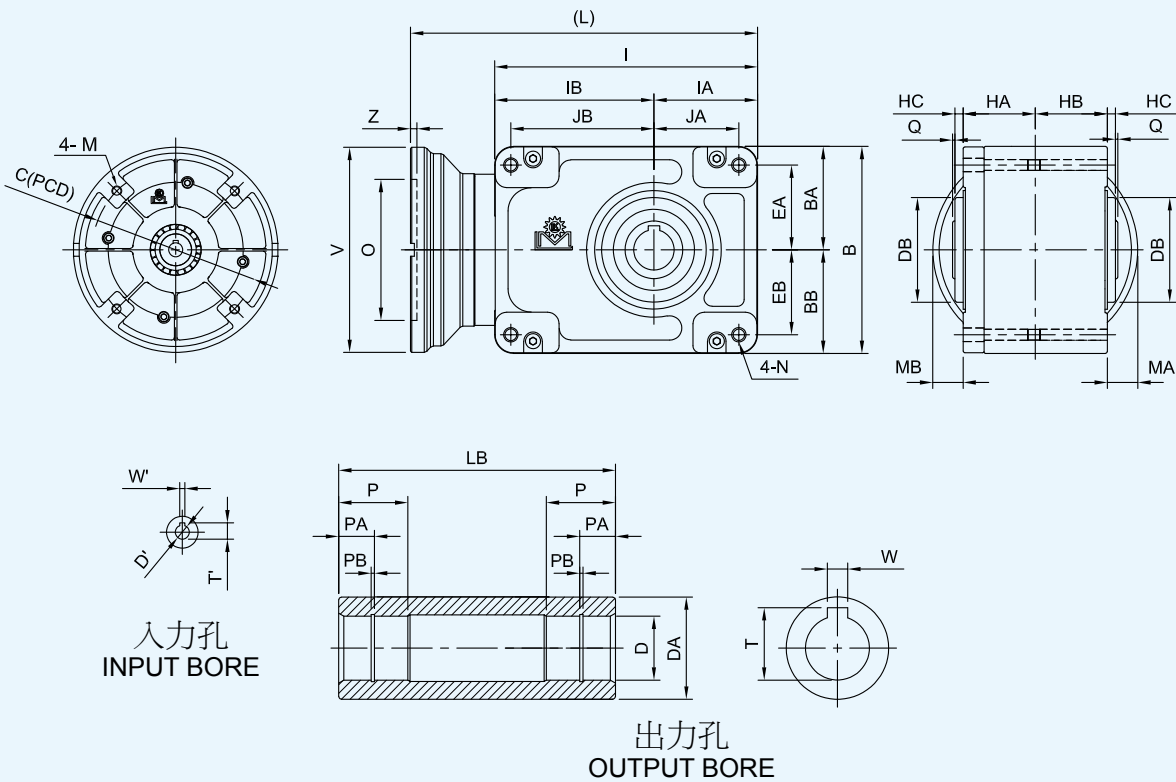

SMALL GEAR REDUCER SERIES



Gear Worm

最大容許扭力 Max. Permissible Torque						
型號 Model No.	09	10	11	12	13	14
扭力 Torque kg-m	5	10	20	40	75	110

unit: mm

	馬力 Horse Power	V	O	Z	M	C	D'	W'	T'
	入力孔 Input Bore	1/8	160	110	5	M8	130	11	4
1/4		160	110	5	M8	130	11	4	12.8
1/2		160	110	5	M8	130	14	5	16.3
1		200	130	5	M10	165	19	6	21.8
2		200	130	5	M10	165	24	8	27.3
3	250	180	5	M12	215	28	8	31.3	

unit: mm

馬力 Horse Power	型號 Model	減速比 Ratio	JA	JB	I	IA	IB	EA	EB	B	BA
1/8HP (0.1kW)	09	1/10~1/175	38	70	128	48	80	38	38	96	48
	10	1/20~1/240	47	88	159	59	100	47	47	118	59
1/4HP (0.2kW)	10	1/20~1/240	47	88	159	59	100	47	47	118	59
	11	1/20~1/290	58	106	187	70	117	58	58	140	70
1/2HP (0.4kW)	11	1/20~1/170	58	106	187	70	117	58	58	140	70
	12	1/20~1/300	73	123	226	89	137	73	73	178	89
1HP (0.75kW)	12	1/20~1/180	73	123	226	89	137	73	73	178	89
	13	1/10~1/310	88	150	278	108	170	88	88	216	108
2HP (1.5kW)	13	1/10~1/185	88	150	278	108	170	88	88	216	108
	14	1/10~1/200	105	182	337	130	207	105	105	260	130
3HP (2.2kW)	14	1/10~1/160	105	182	337	130	207	105	105	260	130

unit: mm

馬力 Horse Power	型號 Model	減速比 Ratio	BB	HA	HB	HC	Q	L	MA	MB	N
1/8HP (0.1kW)	09	1/10~1/175	48	46.5	33.5	6	2	184	46.5	33.5	M8
	10	1/20~1/240	59	50	50	7	2	226	30	30	M10
1/4HP (0.2kW)	10	1/20~1/240	59	50	50	7	2	226	30	30	M10
	11	1/20~1/290	70	59	47	7	2	254	33	21	M10
1/2HP (0.4kW)	11	1/20~1/170	70	59	47	7	2	254	33	21	M10
	12	1/20~1/300	89	69	55	7	2	295	25	11	M12
1HP (0.75kW)	12	1/20~1/180	89	69	55	7	2	309	45	31	M12
	13	1/10~1/310	108	85	65	7	2	366	35	15	M16
2HP (1.5kW)	13	1/10~1/185	108	85	65	7	2	376	35	15	M16
	14	1/10~1/200	130	101	80	10	2	439	20	-	M20
3HP (2.2kW)	14	1/10~1/160	130	101	80	10	2	448	45	24	M20

unit: mm

馬力 Horse Power	型號 Model	減速比 Ratio	出力孔 Output Bore									重量 Weight (KG)
			D	DA	DB	W	T	P	PA	PB	LB	
1/8HP (0.1kW)	09	1/10~1/175	20	30	70	6	22.8	25	13	1.15	96	
	10	1/20~1/240	25	40	90	8	28.3	30	14	1.35	118	
1/4HP (0.2kW)	10	1/20~1/240	25	40	90	8	28.3	30	14	1.35	118	
	11	1/20~1/290	30	45	90	8	33.3	35	17	1.35	124	
1/2HP (0.4kW)	11	1/20~1/170	30	45	90	8	33.3	35	17	1.35	124	
	12	1/20~1/300	35	50	90	10	38.3	40	20	1.75	142	
1HP (0.75kW)	12	1/20~1/180	35	50	90	10	38.3	40	20	1.75	142	
	13	1/10~1/310	45	65	100	14	48.8	50	26	1.95	168	
2HP (1.5kW)	13	1/10~1/185	45	65	100	14	48.8	50	26	1.95	168	
	14	1/10~1/200	55	80	140	16	59.3	60	32	2.2	205	
3HP (2.2kW)	14	1/10~1/160	55	80	140	16	59.3	60	32	2.2	205	

■ 同心軸馬達自裝式齒蝸減速機
 Motor-Driver Gear Worm Reducer(Concentric Shaft)

■ MODEL : SGWB-D

SGWB -D

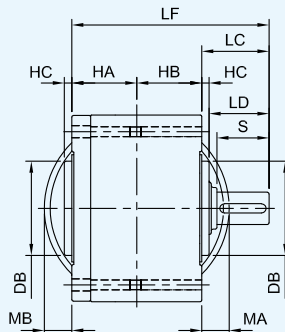
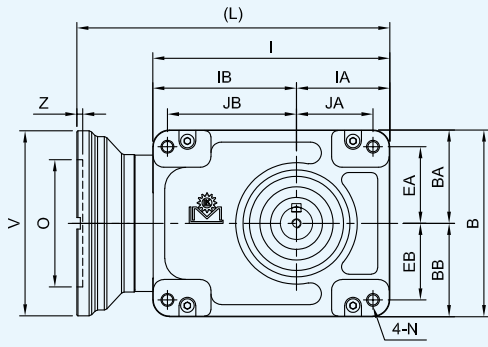

單軸
SINGLE SHAFT

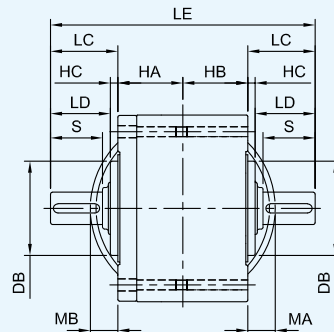

雙軸
DOUBLE SHAFT

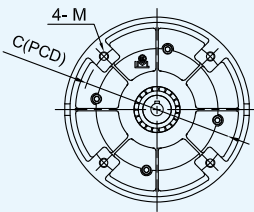

入力孔
INPUT BORE

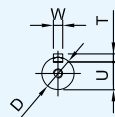
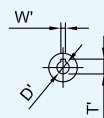

出力軸
OUTPUT SHAFT

SMALL GEAR REDUCER SERIES

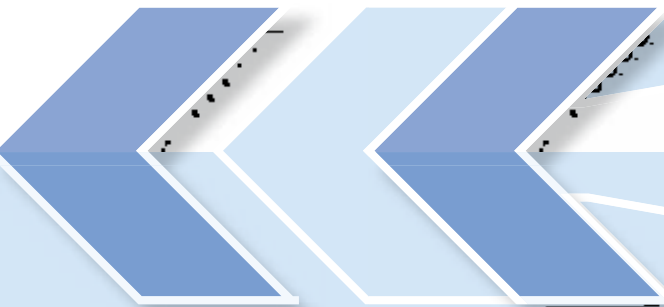

Gear Worm

最大容許扭力 Max. Permissible Torque						
型號 Model No.	09	10	11	12	13	14
扭力 Torque kg-m	5	10	20	40	75	110

unit: mm

	馬力 Horse Power	V	O	Z	M	C	D'	W'	T'
	入力孔 Input Bore	1/8	160	110	5	M8	130	11	4
1/4		160	110	5	M8	130	11	4	12.8
1/2		160	110	5	M8	130	14	5	16.3
1		200	130	5	M10	165	19	6	21.8
2		200	130	5	M10	165	24	8	27.3
	3	250	180	5	M12	215	28	8	31.3

unit: mm

馬力 Horse Power	型號 Model	減速比 Ratio	JA	JB	I	IA	IB	EA	EB	B	BA
1/8HP (0.1kW)	09	1/10~1/175	38	70	128	48	80	38	38	96	48
	10	1/20~1/240	47	88	159	59	100	47	47	118	59
1/4HP (0.2kW)	10	1/20~1/240	47	88	159	59	100	47	47	118	59
	11	1/20~1/290	58	106	187	70	117	58	58	140	70
1/2HP (0.4kW)	11	1/20~1/170	58	106	187	70	117	58	58	140	70
	12	1/20~1/300	73	123	226	89	137	73	73	178	89
1HP (0.75kW)	12	1/20~1/180	73	123	226	89	137	73	73	178	89
	13	1/10~1/310	88	150	278	108	170	88	88	216	108
2HP (1.5kW)	13	1/10~1/185	88	150	278	108	170	88	88	216	108
	14	1/10~1/200	105	182	337	130	207	105	105	260	130
3HP (2.2kW)	14	1/10~1/160	105	182	337	130	207	105	105	260	130

unit: mm

馬力 Horse Power	型號 Model	減速比 Ratio	BB	HA	HB	HC	L	MA	MB	N
1/8HP (0.1kW)	09	1/10~1/175	48	46.5	33.5	6	184	46.5	33.5	M8
	10	1/20~1/240	59	50	50	7	226	30	30	M10
1/4HP (0.2kW)	10	1/20~1/240	59	50	50	7	226	30	30	M10
	11	1/20~1/290	70	59	47	7	254	33	21	M10
1/2HP (0.4kW)	11	1/20~1/170	70	59	47	7	254	33	21	M10
	12	1/20~1/300	89	69	55	7	295	25	11	M12
1HP (0.75kW)	12	1/20~1/180	89	69	55	7	309	45	31	M12
	13	1/10~1/310	108	85	65	7	366	35	15	M16
2HP (1.5kW)	13	1/10~1/185	108	85	65	7	376	35	15	M16
	14	1/10~1/200	130	101	80	10	439	20	-	M20
3HP (2.2kW)	14	1/10~1/160	130	101	80	10	448	45	24	M20

unit: mm

馬力 Horse Power	型號 Model	減速比 Ratio	出力軸 Output Shaft										重量 Weight (KG)
			D	DB	S	W	T	U	LC	LD	LE	LF	
1/8HP (0.1kW)	09	1/10~1/175	18	70	30	6	6	14.5	41	35	162	121	
	10	1/20~1/240	22	90	40	6	6	18.5	54	47	208	154	
1/4HP (0.2kW)	10	1/20~1/240	22	90	40	6	6	18.5	54	47	208	154	
	11	1/20~1/290	28	90	45	8	7	24	59	52	224	165	
1/2HP (0.4kW)	11	1/20~1/170	28	90	45	8	7	24	59	52	224	165	
	12	1/20~1/300	32	90	55	10	8	27	69	62	262	193	
1HP (0.75kW)	12	1/20~1/180	32	90	55	10	8	27	69	62	262	193	
	13	1/10~1/310	40	100	65	12	8	35	79	72	308	229	
2HP (1.5kW)	13	1/10~1/185	40	100	65	12	8	35	79	72	308	229	
	14	1/10~1/200	50	140	75	14	9	44.5	92	82	365	273	
3HP (2.2kW)	14	1/10~1/160	50	140	75	14	9	44.5	92	82	365	273	

■ 同心軸雙軸齒蝸減速機

Double-Axle Gear Worm Reducer(Concentric Shaft)

■ MODEL : SGWD-O

SGWD-O

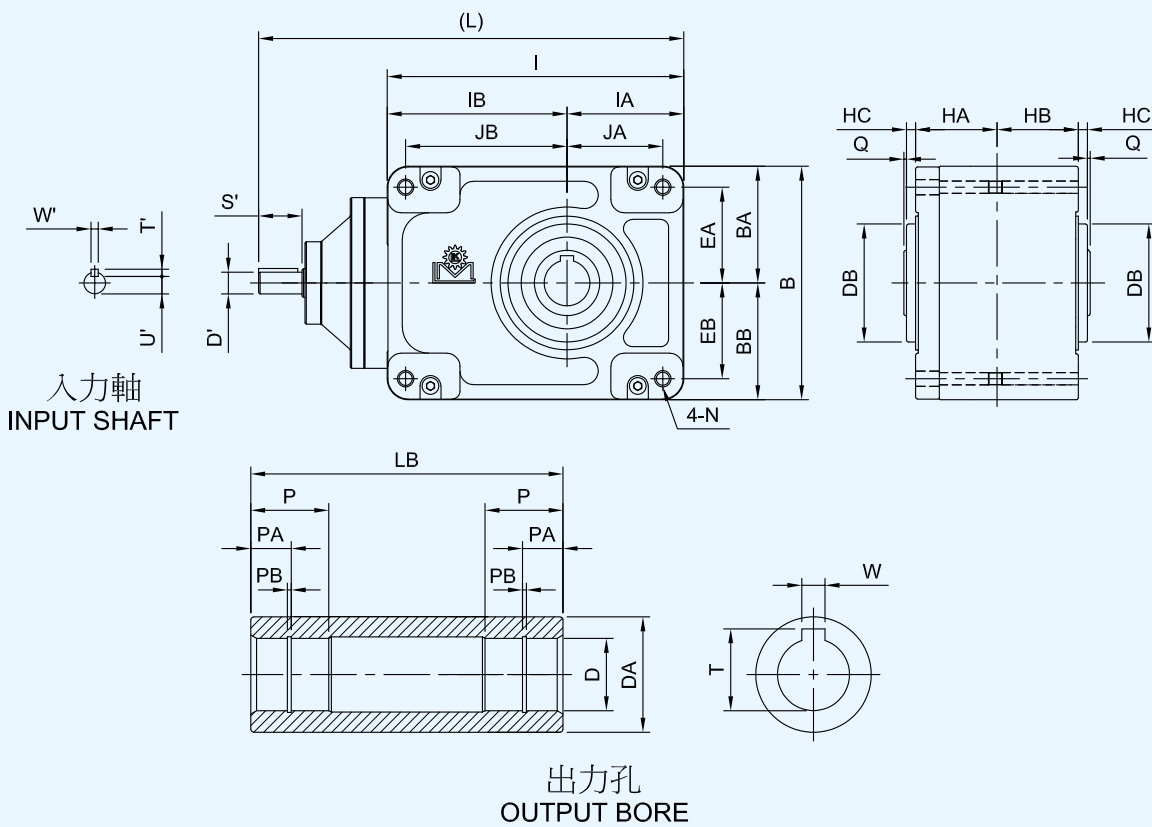

SMALL GEAR REDUCER SERIES



Gear Worm

最大容許扭力 Max. Permissible Torque						
型號 Model No.	09	10	11	12	13	14
扭力 Torque kg-m	5	10	20	40	75	110

unit: mm

	馬力 Horse Power	D'	S'	W'	T'	U'
入力軸 Input Shaft	1/8	12	25	4	4	9.5
	1/4	12	25	4	4	9.5
	1/2	15	30	5	5	12
	1	20	35	6	6	16.5
	2	25	40	8	7	21
	3	30	45	8	7	26

unit: mm

馬力 Horse Power	型號 Model	減速比 Ratio	JA	JB	I	IA	IB	EA	EB	B
1/8HP (0.1kW)	09	1/10~1/175	38	70	128	48	80	38	38	96
	10	1/20~1/240	47	88	159	59	100	47	47	118
1/4HP (0.2kW)	10	1/20~1/240	47	88	159	59	100	47	47	118
	11	1/20~1/290	58	106	187	70	117	58	58	140
1/2HP (0.4kW)	11	1/20~1/170	58	106	187	70	117	58	58	140
	12	1/20~1/300	73	123	226	89	137	73	73	178
1HP (0.75kW)	12	1/20~1/180	73	123	226	89	137	73	73	178
	13	1/10~1/310	88	150	278	108	170	88	88	216
2HP (1.5kW)	13	1/10~1/185	88	150	278	108	170	88	88	216
	14	1/10~1/200	105	182	337	130	207	105	105	260
3HP (2.2kW)	14	1/10~1/160	105	182	337	130	207	105	105	260

unit: mm

馬力 Horse Power	型號 Model	減速比 Ratio	BA	BB	HA	HB	HC	Q	L	N
1/8HP (0.1kW)	09	1/10~1/175	48	48	46.5	33.5	6	2	207	M8
	10	1/20~1/240	59	59	50	50	7	2	244	M10
1/4HP (0.2kW)	10	1/20~1/240	59	59	50	50	7	2	244	M10
	11	1/20~1/290	70	70	59	47	7	2	272	M10
1/2HP (0.4kW)	11	1/20~1/170	70	70	59	47	7	2	277	M10
	12	1/20~1/300	89	89	69	55	7	2	320	M12
1HP (0.75kW)	12	1/20~1/180	89	89	69	55	7	2	339	M12
	13	1/10~1/310	108	108	85	65	7	2	396	M16
2HP (1.5kW)	13	1/10~1/185	108	108	85	65	7	2	411	M16
	14	1/10~1/200	130	130	101	80	10	2	474	M20
3HP (2.2kW)	14	1/10~1/160	130	130	101	80	10	2	490	M20

unit: mm

馬力 Horse Power	型號 Model	減速比 Ratio	出力孔 Output Bore									重量 Weight (KG)
			D	DA	DB	W	T	P	PA	PB	LB	
1/8HP (0.1kW)	09	1/10~1/175	20	30	70	6	22.8	25	13	1.15	96	
	10	1/20~1/240	25	40	90	8	28.3	30	14	1.35	118	
1/4HP (0.2kW)	10	1/20~1/240	25	40	90	8	28.3	30	14	1.35	118	
	11	1/20~1/290	30	45	90	8	33.3	35	17	1.35	124	
1/2HP (0.4kW)	11	1/20~1/170	30	45	90	8	33.3	35	17	1.35	124	
	12	1/20~1/300	35	50	90	10	38.3	40	20	1.75	142	
1HP (0.75kW)	12	1/20~1/180	35	50	90	10	38.3	40	20	1.75	142	
	13	1/10~1/310	45	65	100	14	48.8	50	26	1.95	168	
2HP (1.5kW)	13	1/10~1/185	45	65	100	14	48.8	50	26	1.95	168	
	14	1/10~1/200	55	80	140	16	59.3	60	32	2.2	205	
3HP (2.2kW)	14	1/10~1/160	55	80	140	16	59.3	60	32	2.2	205	

■ 同心軸雙軸齒蝸減速機

Double-Axle Gear Worm Reducer(Concentric Shaft)

■ MODEL : SGWD-D

SGWD -D

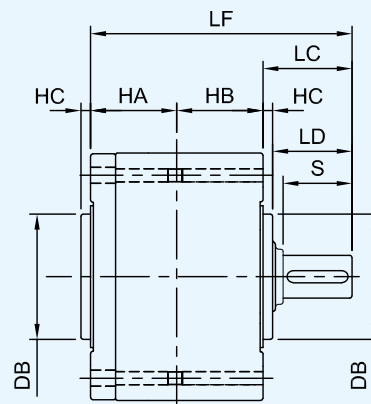
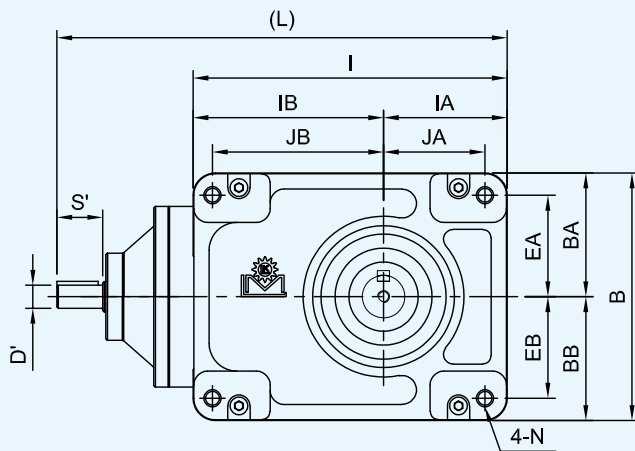

單軸
SINGLE SHAFT

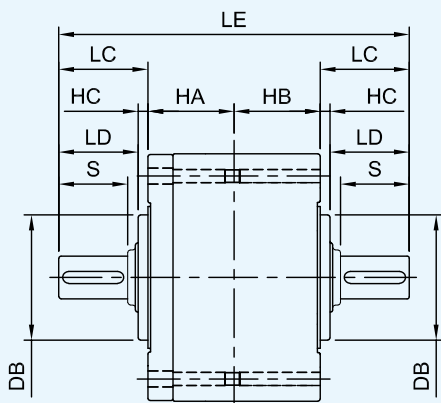

雙軸
DOUBLE SHAFT

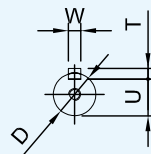

出力軸
OUTPUT SHAFT

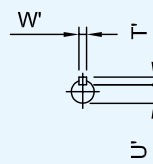

入力軸
INPUT SHAFT

SMALL GEAR REDUCER SERIES



Gear Worm

最大容許扭力 Max. Permissible Torque						
型號 Model No.	09	10	11	12	13	14
扭力 Torque kg-m	5	10	20	40	75	110

unit: mm

	馬力 Horse Power	D'	S'	W'	T'	U'
	入力軸 Input Shaft	1/8	12	25	4	4
1/4		12	25	4	4	9.5
1/2		15	30	5	5	12
1		20	35	6	6	16.5
2		25	40	8	7	21
	3	30	45	8	7	26

unit: mm

馬力 Horse Power	型號 Model	減速比 Ratio	JA	JB	I	IA	IB	EA	EB	B
1/8HP (0.1kW)	09	1/10~1/175	38	70	128	48	80	38	38	96
	10	1/20~1/240	47	88	159	59	100	47	47	118
1/4HP (0.2kW)	10	1/20~1/240	47	88	159	59	100	47	47	118
	11	1/20~1/290	58	106	187	70	117	58	58	140
1/2HP (0.4kW)	11	1/20~1/170	58	106	187	70	117	58	58	140
	12	1/20~1/300	73	123	226	89	137	73	73	178
1HP (0.75kW)	12	1/20~1/180	73	123	226	89	137	73	73	178
	13	1/10~1/310	88	150	278	108	170	88	88	216
2HP (1.5kW)	13	1/10~1/185	88	150	278	108	170	88	88	216
	14	1/10~1/200	105	182	337	130	207	105	105	260
3HP (2.2kW)	14	1/10~1/160	105	182	337	130	207	105	105	260

unit: mm

馬力 Horse Power	型號 Model	減速比 Ratio	BA	BB	HA	HB	HC	L	N
1/8HP (0.1kW)	09	1/10~1/175	48	48	46.5	33.5	6	207	M8
	10	1/20~1/240	59	59	50	50	7	244	M10
1/4HP (0.2kW)	10	1/20~1/240	59	59	50	50	7	244	M10
	11	1/20~1/290	70	70	59	47	7	272	M10
1/2HP (0.4kW)	11	1/20~1/170	70	70	59	47	7	277	M10
	12	1/20~1/300	89	89	69	55	7	320	M12
1HP (0.75kW)	12	1/20~1/180	89	89	69	55	7	339	M12
	13	1/10~1/310	108	108	85	65	7	396	M16
2HP (1.5kW)	13	1/10~1/185	108	108	85	65	7	411	M16
	14	1/10~1/200	130	130	101	80	10	474	M20
3HP (2.2kW)	14	1/10~1/160	130	130	101	80	10	490	M20

unit: mm

馬力 Horse Power	型號 Model	減速比 Ratio	出力軸 Output Shaft										重量 Weight (KG)
			D	DB	S	W	T	U	LC	LD	LE	LF	
1/8HP (0.1kW)	09	1/10~1/175	18	70	30	6	6	14.5	41	35	162	121	
	10	1/20~1/240	22	90	40	6	6	18.5	54	47	208	154	
1/4HP (0.2kW)	10	1/20~1/240	22	90	40	6	6	18.5	54	47	208	154	
	11	1/20~1/290	28	90	45	8	7	24	59	52	224	165	
1/2HP (0.4kW)	11	1/20~1/170	28	90	45	8	7	24	59	52	224	165	
	12	1/20~1/300	32	90	55	10	8	27	69	62	262	193	
1HP (0.75kW)	12	1/20~1/180	32	90	55	10	8	27	69	62	262	193	
	13	1/10~1/310	40	100	65	12	8	35	79	72	308	229	
2HP (1.5kW)	13	1/10~1/185	40	100	65	12	8	35	79	72	308	229	
	14	1/10~1/200	50	140	75	14	9	44.5	92	82	365	273	
3HP (2.2kW)	14	1/10~1/160	50	140	75	14	9	44.5	92	82	365	273	

■ 同心軸多速比齒蝸減速機

High Reduction Gear Worm Reducer(Concentric Shaft)

■ MODEL : SGWL-O

SGWL-O

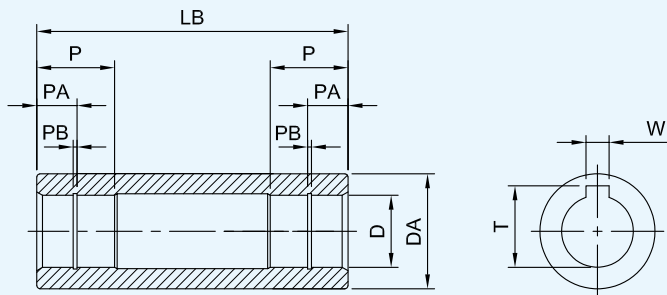
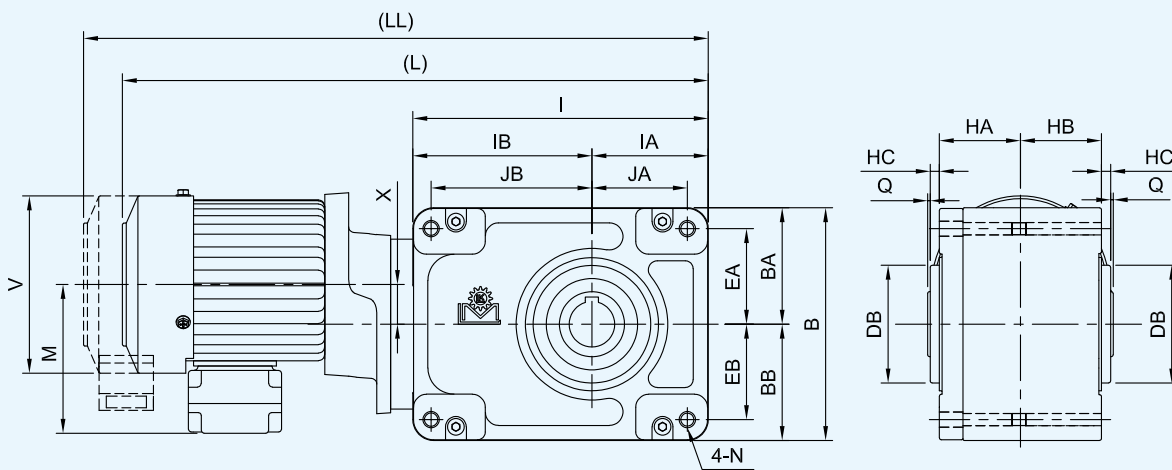

出力孔
OUTPUT BORE

SMALL GEAR REDUCER SERIES

E



Gear Worm

最大容許扭力 Max. Permissible Torque

型號 Model No.	10	11	12	13	14
扭力 Torque kg-m	10	20	40	75	110

unit: mm

馬力 Horse Power	型號 Model	減速比 Ratio	JA	JB	I	IA	IB	EA	EB	B	BA	BB
1/8HP (0.1kW)	10	1/800~1/2400	47	88	159	59	100	47	47	118	59	59
	11	1/800~1/2900	58	106	187	70	117	58	58	140	70	70
1/4HP (0.2kW)	12	1/800~1/3000	73	123	226	89	137	73	73	178	89	89
1/2HP (0.4kW)	13	1/550~1/3100	88	150	278	108	170	88	88	216	108	108
1HP (0.75kW)	14	1/400~1/2000	105	182	337	130	207	105	105	260	130	130

unit: mm

馬力 Horse Power	型號 Model	減速比 Ratio	HA	HB	HC	Q	X	V	M	L	LL	N
1/8HP (0.1kW)	10	1/800~1/2400	50	50	7	2	17.5	137	115	385	400	M10
	11	1/800~1/2900	59	47	7	2	15.5	137	115	410	430	M10
1/4HP (0.2kW)	12	1/800~1/3000	69	55	7	2	22.5	137	115	480	500	M12
1/2HP (0.4kW)	13	1/550~1/3100	85	65	7	2	25.5	151	121	550	555	M16
1HP (0.75kW)	14	1/400~1/2000	101	80	10	2	27	163	128	650	660	M20

unit: mm

馬力 Horse Power	型號 Model	減速比 Ratio	出力孔 Output Bore								重量 Weight (KG)	
			D	DA	DB	W	T	P	PA	PB		LB
1/8HP (0.1kW)	10	1/800~1/2400	25	40	90	8	28.3	30	14	1.35	118	
	11	1/800~1/2900	30	45	90	8	33.3	35	17	1.35	124	
1/4HP (0.2kW)	12	1/800~1/3000	35	50	90	10	38.3	40	20	1.75	142	
1/2HP (0.4kW)	13	1/550~1/3100	45	65	100	14	48.8	50	26	1.95	168	
1HP (0.75kW)	14	1/400~1/2000	55	80	140	16	59.3	60	32	2.2	205	

注:

- 表中 () 內數字系表示輕荷重使用。
- 表中重量以配合三相 4P 馬達為主，其它單相、剎車、直流、特殊等馬達重量另訂。
- 表中 L 內數字以三相馬達為主，其它特殊馬達另訂。
- 如需特殊馬達規格，請洽本司業務。
- 以上數值若有變更，恕不另行通知。

NOTE:

- Values shown in paranthesis () are used for light loading.
- Weights shown in the above chart are based on 3-phase 4P motors, weights for single phase, brake, DC, or special motor shall be referred to specific values.
- Values shown in 'L' column are based on 3-phase motor, other special motor Refer to specific motor refer to specific values.
- For special motor specifications, please contact our business.
- Above specifications are subject to change without prior notice.



■ 同心軸多速比齒蝸減速機

High Reduction Gear Worm Reducer(Concentric Shaft)

■ MODEL : SGWL-D

SGWL -D

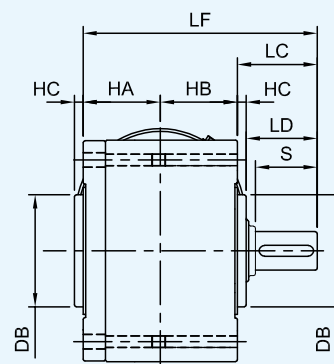
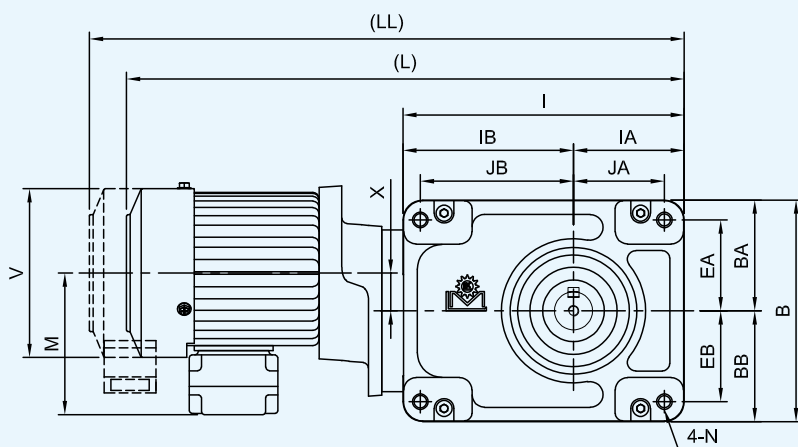

單軸
SINGLE SHAFT

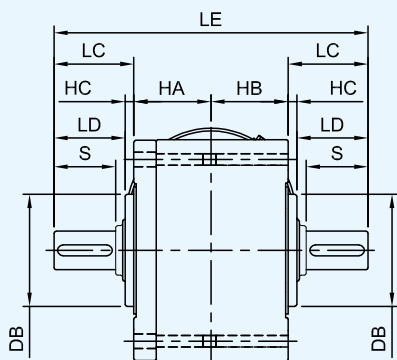

雙軸
DOUBLE SHAFT

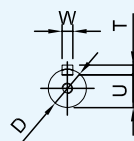

出力軸
OUTPUT SHAFT

SMALL GEAR REDUCER SERIES

E



Gear Worm

最大容許扭力 Max. Permissible Toque					
型號 Model No.	10	11	12	13	14
扭力 Torque kg-m	10	20	40	75	110

unit: mm

馬力 Horse Power	型號 Model	減速比 Ratio	JA	JB	I	IA	IB	EA	EB	B	BA	BB
1/8HP (0.1kW)	10	1/800~1/2400	47	88	159	59	100	47	47	118	59	59
	11	1/800~1/2900	58	106	187	70	117	58	58	140	70	70
1/4HP (0.2kW)	12	1/800~1/3000	73	123	226	89	137	73	73	178	89	89
1/2HP (0.4kW)	13	1/550~1/3100	88	150	278	108	170	88	88	216	108	108
1HP (0.75kW)	14	1/400~1/2000	105	182	337	130	207	105	105	260	130	130

unit: mm

馬力 Horse Power	型號 Model	減速比 Ratio	HA	HB	HC	X	V	M	L	LL	N
1/8HP (0.1kW)	10	1/800~1/2400	50	50	7	17.5	137	115	385	400	M10
	11	1/800~1/2900	59	47	7	15.5	137	115	410	430	M10
1/4HP (0.2kW)	12	1/800~1/3000	69	55	7	22.5	137	115	480	500	M12
1/2HP (0.4kW)	13	1/550~1/3100	85	65	7	25.5	151	121	550	555	M16
1HP (0.75kW)	14	1/400~1/2000	101	80	10	27	163	128	650	660	M20

unit: mm

馬力 Horse Power	型號 Model	減速比 Ratio	出力軸 Output Shaft										重量 Weight (KG)
			D	DB	S	W	T	U	LC	LD	LE	LF	
1/8HP (0.1kW)	10	1/800~1/2400	22	90	40	6	6	18.5	54	47	208	154	
	11	1/800~1/2900	28	90	45	8	7	24	59	52	224	165	
1/4HP (0.2kW)	12	1/800~1/3000	32	90	55	10	8	27	69	62	262	193	
1/2HP (0.4kW)	13	1/550~1/3100	40	100	65	12	8	35	79	72	308	229	
1HP (0.75kW)	14	1/400~1/2000	50	140	75	14	9	44.5	92	82	365	273	

注:

- 表中 () 內數字系表示輕荷重使用。
- 表中重量以配合三相 4P 馬達為主，其它單相、剎車、直流、特殊等馬達重量另訂。
- 表中 L 內數字以三相馬達為主，其它特殊馬達另訂。
- 如需特殊馬達規格，請洽本司業務。
- 以上數值若有變更，恕不另行通知。

NOTE:

- Values shown in paranthesis () are used for light loading.
- Weights shown in the above chart are based on 3-phase 4P motors, weights for single phase, brake, DC, or special motor shall be referred to specific values.
- Values shown in 'L' column are based on 3-phase motor, other special motor Refer to specific motor refer to specific values.
- For special motor specifications, please contact our business.
- Above specifications are subject to change without prior notice.

■ 同心軸多速馬達自裝式齒蝸減速機

High Reduction Motor-Driver Gear Worm Reducer(Concentric Shaft)

■ MODEL : SGWBL-O

SGWBL-O

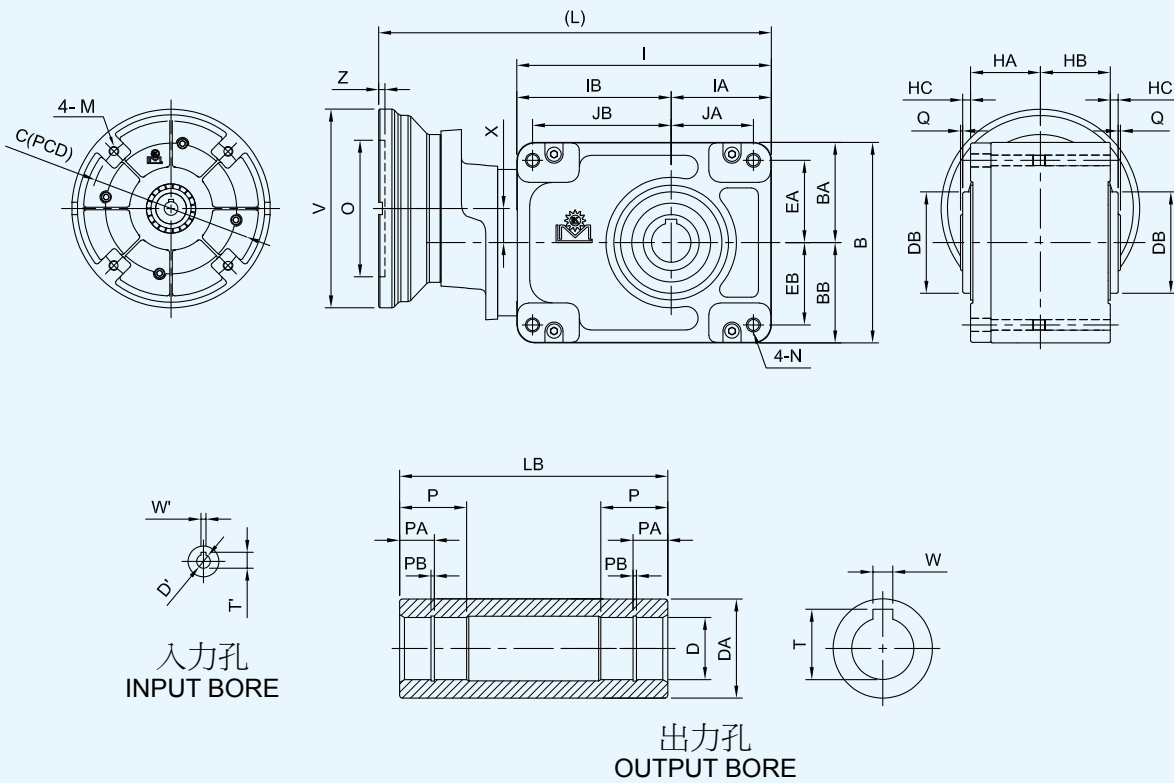

SMALL GEAR REDUCER SERIES

E



Gear Worm

最大容許扭力 Max. Permissible Torque

型號 Model No.	10	11	12	13	14
扭力 Torque kg-m	10	20	40	75	110

unit: mm

入力孔 Input Bore	馬力 Horse Power	V	O	Z	M	C	D'	W'	T'
	1/8	160	110	5	M8	130	11	4	12.8
	1/4	160	110	5	M8	130	11	4	12.8
	1/2	160	110	5	M8	130	14	5	16.3
1	200	130	5	M10	165	19	6	21.8	

unit: mm

馬力 Horse Power	型號 Model	減速比 Ratio	JA	JB	I	IA	IB	EA	EB	B
1/8HP (0.1kW)	10	1/800~1/2400	47	88	159	59	100	47	47	118
	11	1/800~1/2900	58	106	187	70	117	58	58	140
1/4HP (0.2kW)	12	1/800~1/3000	73	123	226	89	137	73	73	178
1/2HP (0.4kW)	13	1/550~1/3100	88	150	278	108	170	88	88	216
1HP (0.75kW)	14	1/400~1/2000	105	182	337	130	207	105	105	260

unit: mm

馬力 Horse Power	型號 Model	減速比 Ratio	BA	BB	HA	HB	HC	Q	X	L	N
1/8HP (0.1kW)	10	1/800~1/2400	59	59	50	50	7	2	17.5	275	M10
	11	1/800~1/2900	70	70	59	47	7	2	15.5	305	M10
1/4HP (0.2kW)	12	1/800~1/3000	89	89	69	55	7	2	22.5	355	M12
1/2HP (0.4kW)	13	1/550~1/3100	108	108	85	65	7	2	25.5	415	M16
1HP (0.75kW)	14	1/400~1/2000	130	130	101	80	10	2	27	510	M20

unit: mm

馬力 Horse Power	型號 Model	減速比 Ratio	出力孔 Output Bore								重量 Weight (KG)
			D	DA	DB	W	T	P	PA	PB	
1/8HP (0.1kW)	10	1/800~1/2400	25	40	90	8	28.3	30	14	1.35	118
	11	1/800~1/2900	30	45	90	8	33.3	35	17	1.35	124
1/4HP (0.2kW)	12	1/800~1/3000	35	50	90	10	38.3	40	20	1.75	142
1/2HP (0.4kW)	13	1/550~1/3100	45	65	100	14	48.8	50	26	1.95	168
1HP (0.75kW)	14	1/400~1/2000	55	80	140	16	59.3	60	32	2.2	205

注:

1. 多速比減速機以定轉速設計，請參考齒箱最大容許扭力。
2. 以上數值若有變更，恕不另行通知。

NOTE:

1. This multistage gear reducer is designed to rotate at fixed speed. Please refer to the maximum allowable torque of the gear box.
2. Above specifications are subject to change without prior notice.

■ 同心軸多速馬達自裝式齒蝸減速機

High Reduction Motor-Driver Gear Worm Reducer(Concentric Shaft)

■ MODEL : SGWBL-D

SGWBL -D

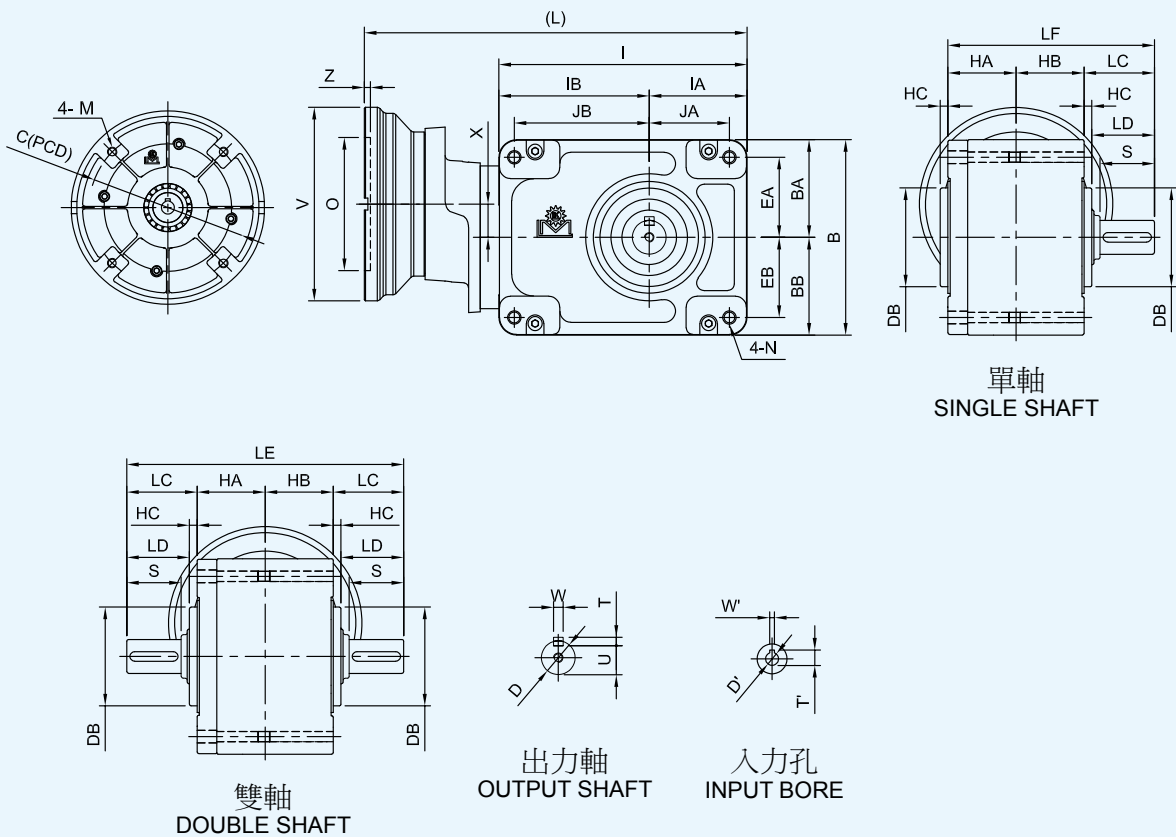



Gear Worm

最大容許扭力 Max. Permissible Torque

型號 Model No.	10	11	12	13	14
扭力 Torque kg-m	10	20	40	75	110

unit: mm

入力孔 Input Bore	馬力 Horse Power	V	O	Z	M	C	D'	W'	T'
	1/8	160	110	5	M8	130	11	4	12.8
	1/4	160	110	5	M8	130	11	4	12.8
	1/2	160	110	5	M8	130	14	5	16.3
	1	200	130	5	M10	165	19	6	21.8

unit: mm

馬力 Horse Power	型號 Model	減速比 Ratio	JA	JB	I	IA	IB	EA	EB	B
1/8HP (0.1kW)	10	1/800~1/2400	47	88	159	59	100	47	47	118
	11	1/800~1/2900	58	106	187	70	117	58	58	140
1/4HP (0.2kW)	12	1/800~1/3000	73	123	226	89	137	73	73	178
1/2HP (0.4kW)	13	1/550~1/3100	88	150	278	108	170	88	88	216
1HP (0.75kW)	14	1/400~1/2000	105	182	337	130	207	105	105	260

unit: mm

馬力 Horse Power	型號 Model	減速比 Ratio	BA	BB	HA	HB	HC	X	L	N
1/8HP (0.1kW)	10	1/800~1/2400	59	59	50	50	7	17.5	275	M10
	11	1/800~1/2900	70	70	59	47	7	15.5	305	M10
1/4HP (0.2kW)	12	1/800~1/3000	89	89	69	55	7	22.5	355	M12
1/2HP (0.4kW)	13	1/550~1/3100	108	108	85	65	7	25.5	415	M16
1HP (0.75kW)	14	1/400~1/2000	130	130	101	80	10	27	510	M20

unit: mm

馬力 Horse Power	型號 Model	減速比 Ratio	出力軸 Output Shaft										重量 Weight (KG)
			D	DB	S	W	T	U	LC	LD	LE	LF	
1/8HP (0.1kW)	10	1/800~1/2400	22	90	40	6	6	18.5	54	47	208	154	
	11	1/800~1/2900	28	90	45	8	7	24	59	52	224	165	
1/4HP (0.2kW)	12	1/800~1/3000	32	90	55	10	8	27	69	62	262	193	
1/2HP (0.4kW)	13	1/550~1/3100	40	100	65	12	8	35	79	72	308	229	
1HP (0.75kW)	14	1/400~1/2000	50	140	75	14	9	44.5	92	82	365	273	

注:

1. 多速比減速機以定轉速設計，請參考齒箱最大容許扭力。
2. 以上數值若有變更，恕不另行通知。

NOTE:

1. This multistage gear reducer is designed to rotate at fixed speed. Please refer to the maximum allowable torque of the gear box.
2. Above specifications are subject to change without prior notice.

■ 同心軸多速雙軸齒蝸減速機

High Reduction Double-Axle Gear Worm Reducer(Concentric Shaft)

■ MODEL : SGWDL-O

SGWDL-O

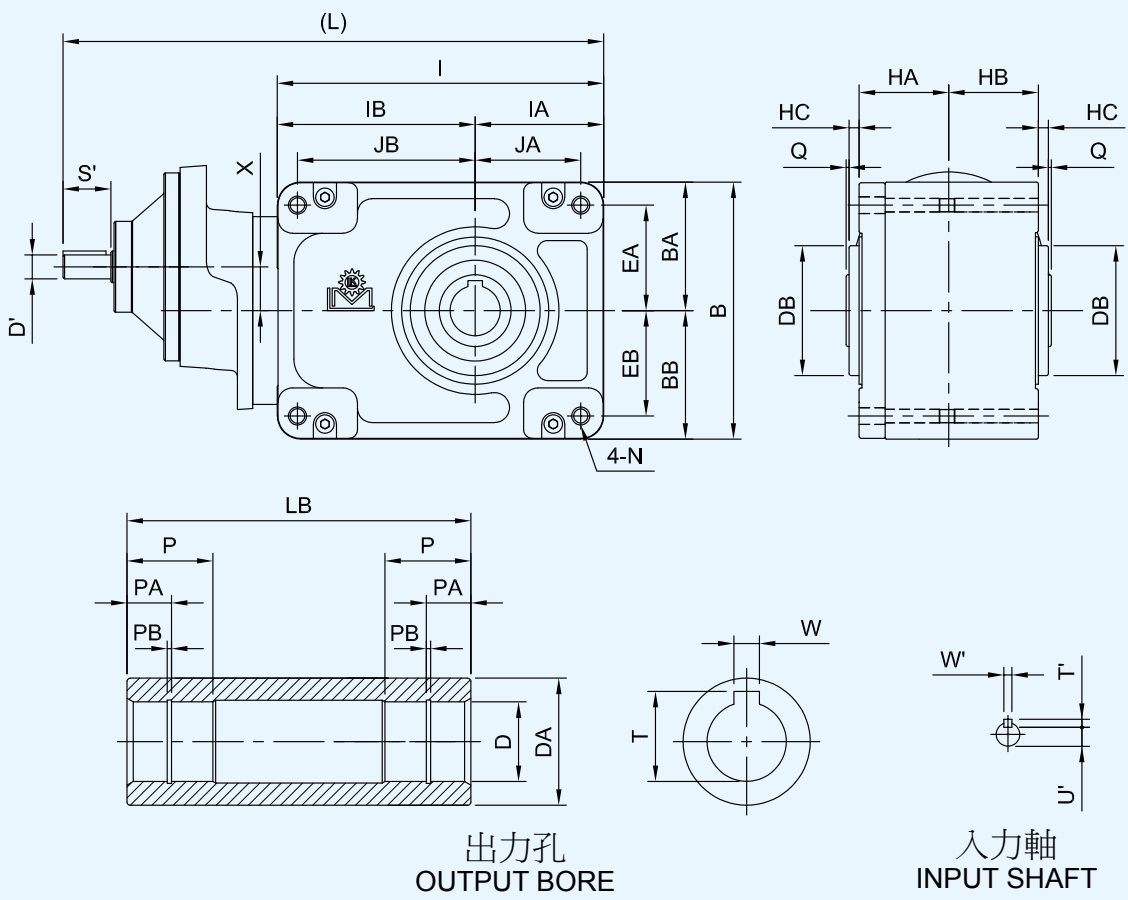

SMALL GEAR REDUCER SERIES

E



Gear Worm

最大容許扭力 Max. Permissible Torque					
型號 Model No.	10	11	12	13	14
扭力 Torque kg-m	10	20	40	75	110

unit: mm						
入力軸 Input Shaft	馬力 Horse Power	D'	S'	W'	T'	U'
	1/8	12	25	4	4	9.5
	1/4	12	25	4	4	9.5
	1/2	15	30	5	5	12
	1	20	35	6	6	16.5

unit: mm										
馬力 Horse Power	型號 Model	減速比 Ratio	JA	JB	I	IA	IB	EA	EB	B
1/8HP (0.1kW)	10	1/800~1/2400	47	88	159	59	100	47	47	118
	11	1/800~1/2900	58	106	187	70	117	58	58	140
1/4HP (0.2kW)	12	1/800~1/3000	73	123	226	89	137	73	73	178
1/2HP (0.4kW)	13	1/550~1/3100	88	150	278	108	170	88	88	216
1HP (0.75kW)	14	1/400~1/2000	105	182	337	130	207	105	105	260

unit: mm											
馬力 Horse Power	型號 Model	減速比 Ratio	BA	BB	HA	HB	HC	Q	X	L	N
1/8HP (0.1kW)	10	1/800~1/2400	59	59	50	50	7	2	17.5	295	M10
	11	1/800~1/2900	70	70	59	47	7	2	15.5	320	M10
1/4HP (0.2kW)	12	1/800~1/3000	89	89	69	55	7	2	22.5	370	M12
1/2HP (0.4kW)	13	1/550~1/3100	108	108	85	65	7	2	25.5	440	M16
1HP (0.75kW)	14	1/400~1/2000	130	130	101	80	10	2	27	540	M20

unit: mm												
馬力 Horse Power	型號 Model	減速比 Ratio	出力孔 Output Bore									重量 Weight (KG)
			D	DA	DB	W	T	P	PA	PB	LB	
1/8HP (0.1kW)	10	1/800~1/2400	25	40	90	8	28.3	30	14	1.35	118	
	11	1/800~1/2900	30	45	90	8	33.3	35	17	1.35	124	
1/4HP (0.2kW)	12	1/800~1/3000	35	50	90	10	38.3	40	20	1.75	142	
1/2HP (0.4kW)	13	1/550~1/3100	45	65	100	14	48.8	50	26	1.95	168	
1HP (0.75kW)	14	1/400~1/2000	55	80	140	16	59.3	60	32	2.2	205	

注：
1. 多速比減速機以定轉速設計，請參考齒箱最大容許扭力。
2. 以上數值若有變更，恕不另行通知。

NOTE:
1. This multistage gear reducer is designed to rotate at fixed speed. Please refer to the maximum allowable torque of the gear box.
2. Above specifications are subject to change without prior notice.



同心軸多速雙軸齒蝸減速機

High Reduction Double-Axle Gear Worm Reducer(Concentric Shaft)

MODEL : SGWDL-D

SGWDL -D

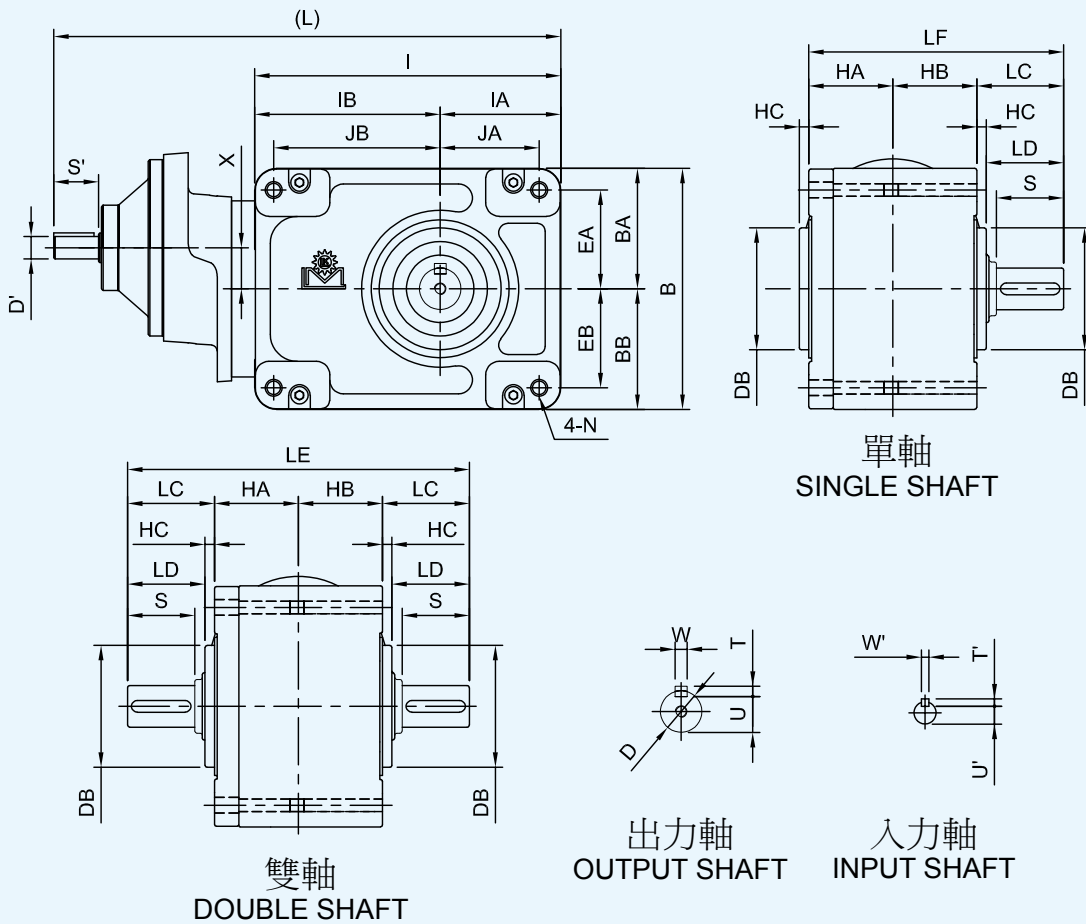

SMALL GEAR REDUCER SERIES

E



Gear Worm

unit: mm

最大容許扭力 Max. Permissible Torque					
型號 Model No.	10	11	12	13	14
扭力 Torque kg-m	10	20	40	75	110

入力軸 Input Shaft	馬力 Horse Power	D'	S'	W'	T'	U'
	1/8	12	25	4	4	9.5
	1/4	12	25	4	4	9.5
	1/2	15	30	5	5	12
	1	20	35	6	6	16.5

unit: mm

馬力 Horse Power	型號 Model	減速比 Ratio	JA	JB	I	IA	IB	EA	EB	B
1/8HP (0.1kW)	10	1/800~1/2400	47	88	159	59	100	47	47	118
	11	1/800~1/2900	58	106	187	70	117	58	58	140
1/4HP (0.2kW)	12	1/800~1/3000	73	123	226	89	137	73	73	178
1/2HP (0.4kW)	13	1/550~1/3100	88	150	278	108	170	88	88	216
1HP (0.75kW)	14	1/400~1/2000	105	182	337	130	207	105	105	260

unit: mm

馬力 Horse Power	型號 Model	減速比 Ratio	BA	BB	HA	HB	HC	X	L	N
1/8HP (0.1kW)	10	1/800~1/2400	59	59	50	50	7	17.5	295	M10
	11	1/800~1/2900	70	70	59	47	7	15.5	320	M10
1/4HP (0.2kW)	12	1/800~1/3000	89	89	69	55	7	22.5	370	M12
1/2HP (0.4kW)	13	1/550~1/3100	108	108	85	65	7	25.5	440	M16
1HP (0.75kW)	14	1/400~1/2000	130	130	101	80	10	27	540	M20

unit: mm

馬力 Horse Power	型號 Model	減速比 Ratio	出力軸 Output Shaft										重量 Weight (KG)
			D	DB	S	W	T	U	LC	LD	LE	LF	
1/8HP (0.1kW)	10	1/800~1/2400	22	90	40	6	6	18.5	54	47	208	154	
	11	1/800~1/2900	28	90	45	8	7	24	59	52	224	165	
1/4HP (0.2kW)	12	1/800~1/3000	32	90	55	10	8	27	69	62	262	193	
1/2HP (0.4kW)	13	1/550~1/3100	40	100	65	12	8	35	79	72	308	229	
1HP (0.75kW)	14	1/400~1/2000	50	140	75	14	9	44.5	92	82	365	273	

注:

1. 多速比減速機以定轉速設計，請參考齒箱最大容許扭力。
2. 以上數值若有變更，恕不另行通知。

NOTE:

1. This multistage gear reducer is designed to rotate at fixed speed. Please refer to the maximum allowable torque of the gear box.
2. Above specifications are subject to change without prior notice.

伺服用小型齒輪減速機

Small Gear Reducer For Servo Motor

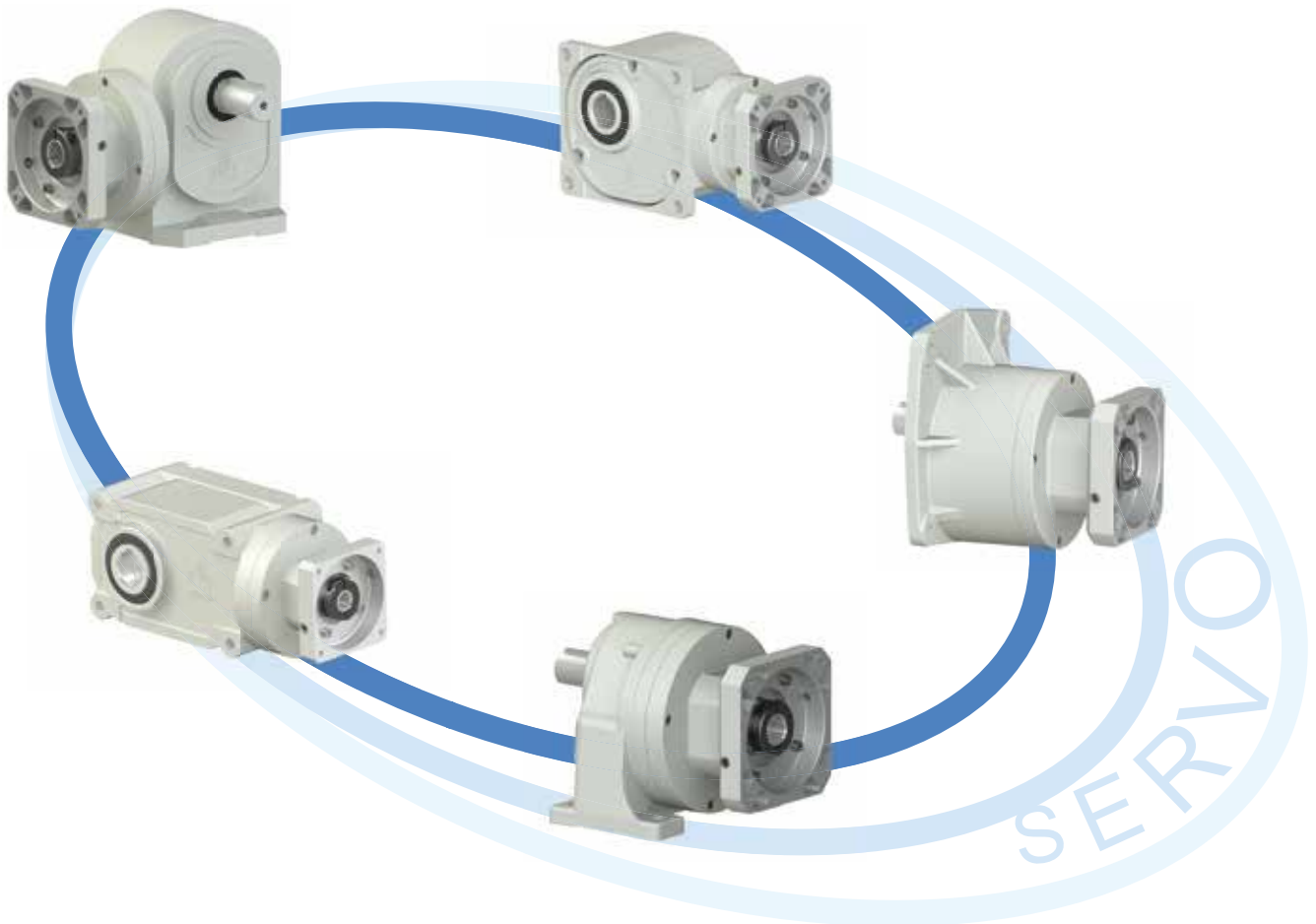

機種型號表示 Indication of Model Numbers

SH	A	10	□	□	1/8	1/5
機型 Type	機種 Type	型號 Model	法蘭型式 Flange Type	出力軸表示 Output	馬力 Horse Power	減速比 Ratio
SH	A: 伺服介面 Servo Type	09	□: 無 None	□: 無 None	1/8 HP	1/5
SV		10	S: 短框 Short	O: 中空軸 Hollow Shaft	1/4 HP	~
SLH		11	Frame	D: 實心軸 Solid Shaft	1/2 HP	1/2500
SLF		12	L: 長框 Long		1 HP	
SK		13	Frame		2 HP	※
SGW		14	Frame		3 HP	

※ 表中減速比以公稱速比，如需實際速比，請另告知。
The reduction ration in the table are nominal ratios. Please contact us if your need actual ratios.

■ 伺服馬達盤規格表

Specifications Table for Flange of Servo Motor

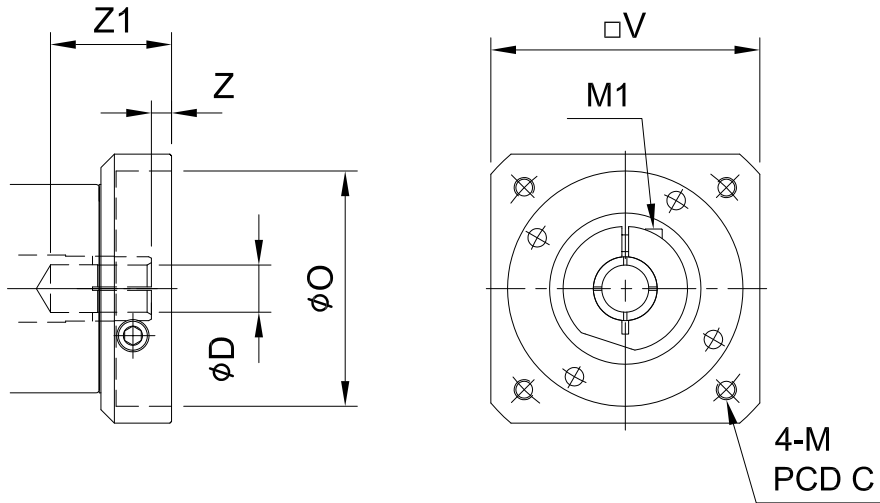

unit: mm

伺服馬達盤型式 Servomotor Flange Type	D	O	M	C	V	M1	Z	Z1
F0	11	30	M3,M4	45 / 46	46	M4	5	31
		40	M4,M5	63	55			
		50	M4,M5	60 / 70	55 / 60			
F1	14	50	M4,M5	70	64	M5	6	36
		60	M5,M6	75	70			
		70	M5,M6	90	80			
F2	24	110	M8	145	130	M6	9.5	57.5
		95	M6,M8	115	110			
		80	M5,M6	100	92			
		70	M5,M6	90	92			
F3	28	95	M6,M8	115	122	M8	10	67
		110	M8,M10	145	130			
		130	M10	165	150			

■ 軸套

Bushing

注：伺服馬達規格尺寸不一，訂購時請提供相關資料。

NOTE: Servo motor specifications are inconsistent, please provide relevant information when ordering.

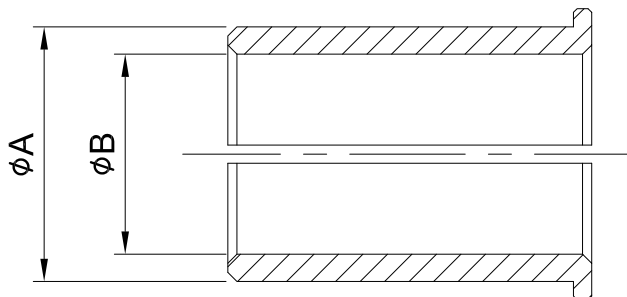

unit: mm

軸套內徑為所使用伺服馬達的輸出軸軸徑，請客戶依需求自行選訂。

The bore diameter of the bushing is the shaft diameter of the output shaft of the servo motor, please choose according to your needs.

連接軸_孔徑 Shaft Bore ØA	軸套_孔徑 Bushing Bore ØB							
11	9	8	6	5.65				
14	12.7	12	11	10	9	8	6.35	6
24	22	19	16	14				
28	25	24	22	19	16			

■ 臥式減速機 - 伺服馬達用 Horizontal Motor-Driver Reducer For Servo Motor

■ MODEL : SHA



SHA

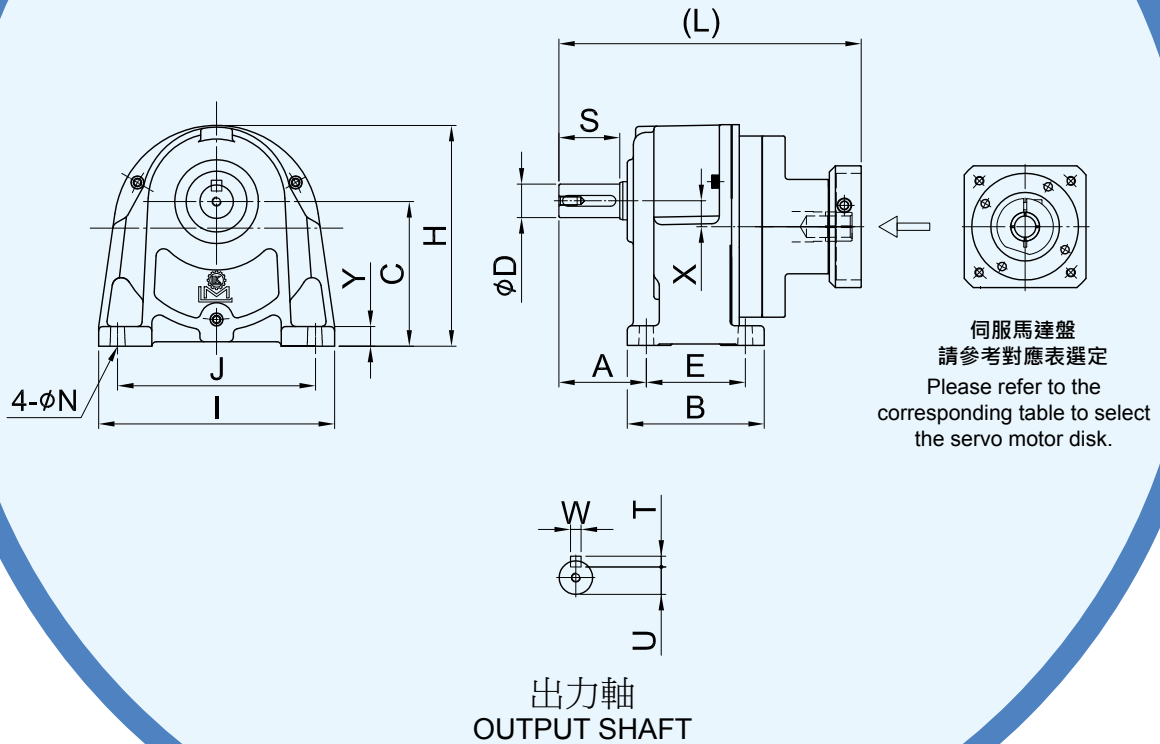

最大容許扭力 Max. Permissible Torque						
型號 Model No.	10	11	12	13	14	15
扭力 Torque kg-m	3	10	20	40	75	110

伺服馬達盤對應表	
型號	適用馬達盤
10	F1
11	F1
12	F2
13	F2 F3
14	F2 F3
15	F2 F3

unit: mm

型號 Model	減速比 Ratio	A	E	B	J	I	C	H	Y	N	X	L	出力軸 Output Shaft					重量 Weight (KG)
													D	S	W	T	U	
10	1/3~1/30 (1/40~1/155)	46	40	65	110	135	85	148	12	9	17	176	18	30	5	5	15	
11	1/6~1/200	57	65	90	130	155	95	158	13	9	17	198	22	40	7	7	18	
12	1/35~1/200	66	90	120	140	180	115	174	15	11	23	242	28	45	7	7	24	
13	1/25~1/200	78	130	165	170	210	130	205	18	13	26	F2 269 / F3 298	32	55	10	8	27	
14	1/35~1/180 (1/200)	95	150	195	210	255	150	240	20	15	28	F2 312 / F3 341	40	65	10	8	35	
15	1/80~1/150 (1/170~1/200)	112	170	225	265	330	185	295	25	19	38	F2 345 / F3 374	50	80	14	9	44.5	

■ 立式減速機 - 伺服馬達用 Vertical Motor-Driver Reducer For Servo Motor

■ MODEL : SVA

SVA

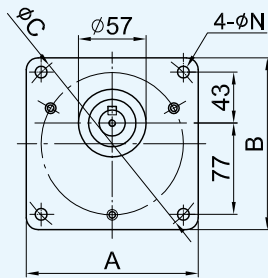

SVB-A 法蘭面Flange
型號Model:11

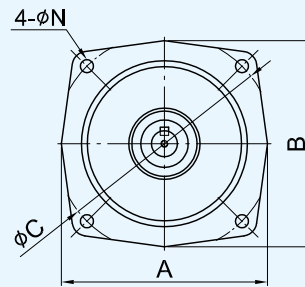

SVB(B法蘭面Flange)
型號Model:11,12,13,14

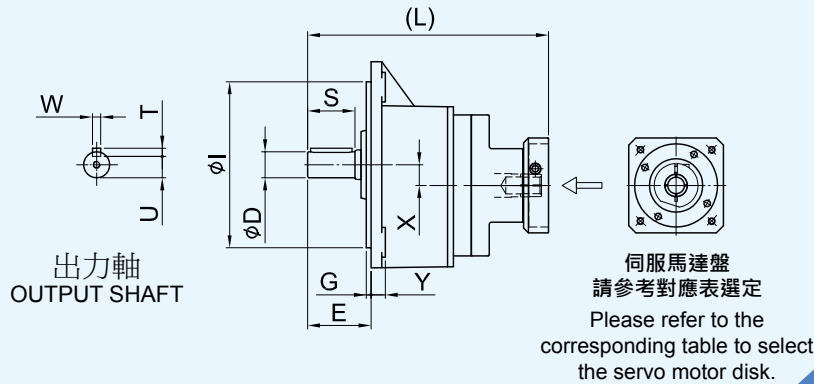

最大容許扭力 Max. Permissible Torque						
型號 Model No.	10	11	12	13	14	15
扭力 Torque kg-m	3	10	20	40	75	110

伺服馬達盤對應表	
型號	適用馬達盤
10	F1
11	F1
12	F2
13	F2 F3
14	F2 F3
15	F2 F3

unit: mm

型號 Model	減速比 Ratio	A	B	C	N	I	E	G	Y	X	L	出力軸 Output Shaft					重量 Weight (KG)
												D	S	W	T	U	
SVB-A10	1/3~1/30 (1/40~1/155)	122	122	140	9	-	33	-	10	17	176	18	30	5	5	15	
SVB-10		158	158	170	9	120	36	3	10	17	176	18	30	5	5	15	
SVB-A11	1/6~1/200	145	145	170	11	-	47	4	12	17	198	22	40	7	7	18	
SVB-11		174	174	185	11	140	49	4	12	17	198	22	40	7	7	18	
12	1/35~1/200	217	217	235	11	180	57	6	15	23	242	28	45	7	7	24	
13	1/25~1/200	250	250	280	13	220	65	5	17	26	F2 269 / F3 298	32	55	10	8	27	
14	1/35~1/180 (1/200)	260	276	310	18	230	77	5	20	28	F2 312 / F3 341	40	65	10	8	35	



小型齒輪減速機系列

■ 臥式戟齒減速機 - 伺服馬達用

Horizontal Motor-Driver Hypoid Gear Reducer For Servo Motor

■ MODEL : SLHA

SLHA

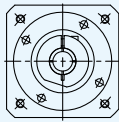

伺服馬達盤
請參考對應表選定
Please refer to the
corresponding table to select
the servo motor disk.

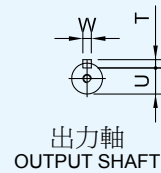
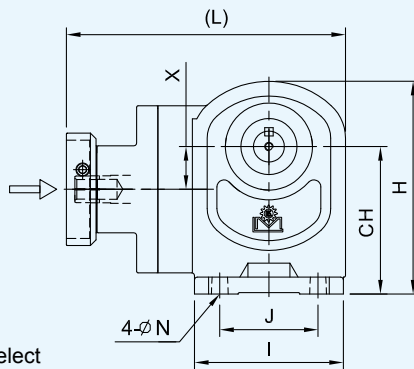

出力軸
OUTPUT SHAFT

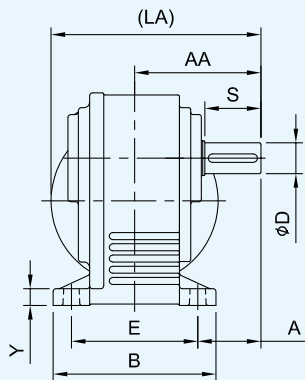

左軸
LEFT SHAFT

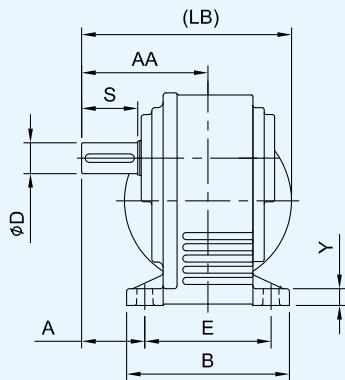

右軸
RIGHT SHAFT

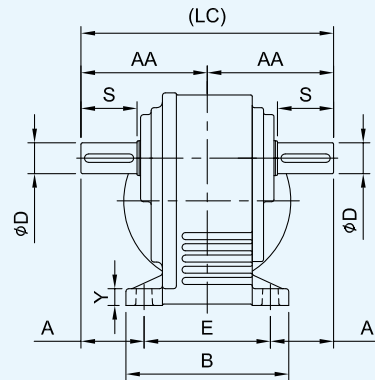

雙軸
DOUBLE SHAFT



S E R V O

伺服馬達盤對應表

型號	適用馬達盤
09	F0
10	F1
11	F1
12	F2
13	F2 F3
14	F2 F3

最大容許扭力 Max. Permissible Torque

型號 Model No.	09	10	11	12	13	14
扭力 Torque kg-m	5	10	20	40	75	110

unit: mm

型號 Model	減速比 Ratio	A	AA	J	I	E	B	CH	H	Y	N	X	L
09	1/5~1/230(1/250~1/290)	35.5	80.5	60	96	90	110	90	138	10	9	31	173
10	1/5~1/200(1/230~1/260)	45	90	70	106	90	116	105	152	12	11	30	199
11	1/5~1/200(1/225~1/250)	50	100	80	127	100	126	120	177	15	11	41	213
12	1/5~1/200(1/225~1/250)	60	120	95	154	120	150	140	208	18	13	47	245
13	1/5~1/200(1/240)	70	140	120	180	140	180	165	251	20	15	59	F2 277 / F3 306
14	1/5~1/160(1/185~1/250)	75	165	150	210	180	230	200	310	25	18	68	F2 336 / F3 366

unit: mm

型號 Model	減速比 Ratio	LA	LB	LC	出力軸 Output Shaft					重量 Weight (KG)
					D	S	W	T	U	
09	1/5~1/230(1/250~1/290)	129	129	161	18	30	6	6	14.5	
10	1/5~1/200(1/230~1/260)	150	150	180	22	40	6	6	18.5	
11	1/5~1/200(1/225~1/250)	160	160	200	28	45	8	7	24	
12	1/5~1/200(1/225~1/250)	193	193	240	32	55	10	8	27	
13	1/5~1/200(1/240)	222	222	280	40	65	12	8	35	
14	1/5~1/160(1/185~1/250)	280	280	330	50	75	14	9	44.5	



小型齒輪減速機系列

■ 法蘭式戟齒減速機 - 伺服馬達用

Flange Motor-Driver Hypoid Gear Reducer For Servo Motor

■ MODEL : SLFA-O

SLFA-O

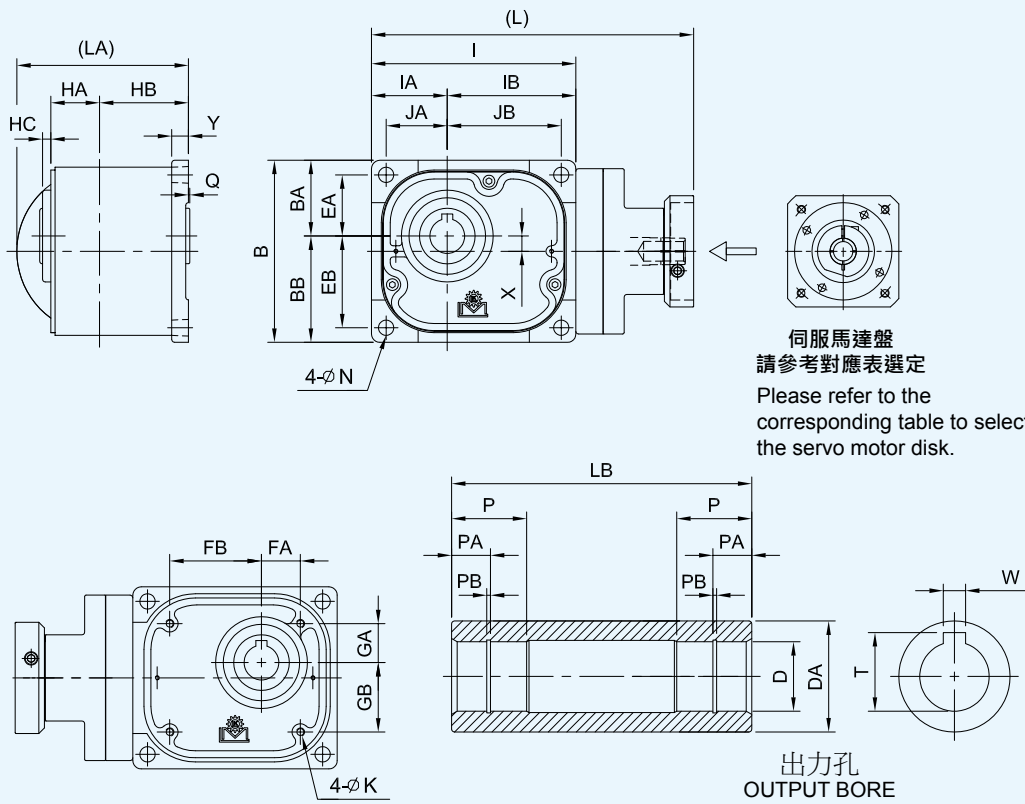



S E R V O

型號	適用馬達盤
09	F0
10	F1
11	F1
12	F2
13	F2 F3
14	F2 F3

型號 Model No.	09	10	11	12	13	14
扭力 Torque kg-m	5	10	20	40	75	110

unit: mm

型號 Model	減速比 Ratio	JA	JB	I	IA	IB	EA	EB	B	BA	BB	FA	FB
09	1/5~1/230(1/250~1/290)	38	72	128	47	81	38	56	112	47	65	25	59
10	1/5~1/200(1/240)	44	82	147	55	93	44	66	131	55	77	28	66
11	1/5~1/210(1/260)	50	90	164	62	102	50	72	146	62	84	33	73
12	1/5~1/200(1/225~1/250)	56	108	188	68	120	56	88	170	69	101	38	90
13	1/5~1/200(1/240~1/260)	70	134	234	85	149	70	104	204	85	119	48	112
14	1/5~1/160(1/180~1/285)	90	168	298	110	188	90	132	262	110	152	58	136

unit: mm

型號 Model	減速比 Ratio	GA	GB	HA	HB	HC	Q	Y	X	L	LA	K	N
09	1/5~1/230(1/250~1/290)	25	43	29	51	8	1	10	9	198	96	M5	9
10	1/5~1/200(1/240)	28	50	35	64	6	1	12	11	232	124	M6	11
11	1/5~1/210(1/260)	33	55	42	65	7	1	14	11	249	125	M8	11
12	1/5~1/200(1/225~1/250)	38	70	44	70	7	1	16	16	277	135	M8	13
13	1/5~1/200(1/240~1/260)	48	82	51	80	6	1	18	17	F2 324 / F3 353	153	M10	15
14	1/5~1/160(1/180~1/285)	58	100	71	98	9	1	22	21	F2 410 / F3 440	178	M12	18

unit: mm

型號 Model	減速比 Ratio	出力孔 Output Bore								重量 Weight (KG)
		D	DA	W	T	P	PA	PB	LB	
09	1/5~1/230(1/250~1/290)	20	30	6	22.8	24	13	1.15	91	
10	1/5~1/200(1/240)	25	40	8	28.3	30	14	1.35	108	
11	1/5~1/210(1/260)	30	45	8	33.3	35	17	1.35	117	
12	1/5~1/200(1/225~1/250)	35	50	10	38.3	40	20	1.75	124	
13	1/5~1/200(1/240~1/260)	45	65	14	48.8	50	26	1.95	140	
14	1/5~1/160(1/180~1/285)	55	80	16	59.3	60	32	2.2	181	

■ 法蘭式戟齒減速機 - 伺服馬達用
 Flange Motor-Driver Hypoid Gear Reducer For Servo Motor

■ MODEL : SLFA-D

SLFA-D

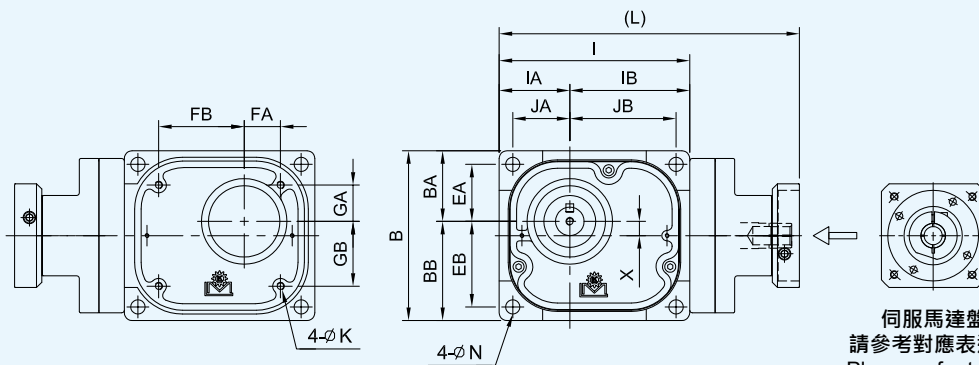

伺服馬達盤
 請參考對應表選定
 Please refer to the
 corresponding table to select
 the servo motor disk.

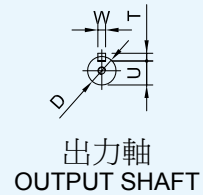
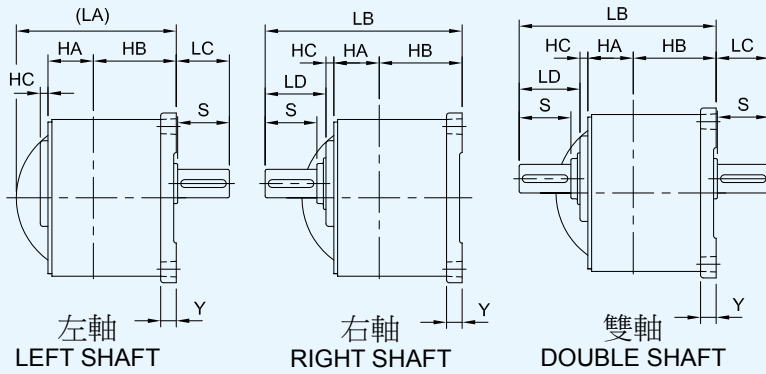



S E R V O

伺服馬達盤對應表

型號	適用馬達盤
09	F0
10	F1
11	F1
12	F2
13	F2 F3
14	F2 F3

最大容許扭力 Max. Permissible Torque

型號 Model No.	09	10	11	12	13	14
扭力 Torque kg-m	5	10	20	40	75	110

unit: mm

型號 Model	減速比 Ratio	JA	JB	I	IA	IB	EA	EB	B	BA	BB	FA	FB
09	1/5~1/230(1/250~1/290)	38	72	128	47	81	38	56	112	47	65	25	59
10	1/5~1/200(1/240)	44	82	147	55	93	44	66	131	55	77	28	66
11	1/5~1/210(1/260)	50	90	164	62	102	50	72	146	62	84	33	73
12	1/5~1/200(1/225~1/250)	56	108	188	68	120	56	88	170	69	101	38	90
13	1/5~1/200(1/240~1/260)	70	134	234	85	149	70	104	204	85	119	48	112
14	1/5~1/160(1/180~1/285)	90	168	298	110	188	90	132	262	110	152	58	136

unit: mm

型號 Model	減速比 Ratio	GA	GB	HA	HB	HC	Y	X	L	LA	K	N
09	1/5~1/230(1/250~1/290)	25	43	29	51	8	10	9	198	96	M5	9
10	1/5~1/200(1/240)	28	50	35	64	6	12	11	232	124	M6	11
11	1/5~1/210(1/260)	33	55	42	65	7	14	11	249	125	M8	11
12	1/5~1/200(1/225~1/250)	38	70	44	70	7	16	16	277	135	M8	13
13	1/5~1/200(1/240~1/260)	48	82	51	80	6	18	17	F2 324 / F3 353	153	M10	15
14	1/5~1/160(1/180~1/285)	58	100	71	98	9	22	21	F2 410 / F3 440	178	M12	18

unit: mm

型號 Model	減速比 Ratio	出力軸 Output Shaft								重量 Weight (KG)
		D	S	W	T	U	LB	LC	LD	
09	1/5~1/230(1/250~1/290)	18	30	6	6	14.5	123	34	35	
10	1/5~1/200(1/240)	22	40	6	6	18.5	152	41	47	
11	1/5~1/210(1/260)	28	45	8	7	24	166	50	52	
12	1/5~1/200(1/225~1/250)	32	55	10	8	27	183	61	62	
13	1/5~1/200(1/240~1/260)	40	65	12	8	35	209	71	72	
14	1/5~1/160(1/180~1/285)	50	75	14	9	44.5	260	81	82	

■ 同心軸戟齒減速機 - 伺服馬達用
 Motor-Driver Hypoid Gear Reducer For Servo Motor(Concentric Shaft)

■ MODEL : SKA-SO / SKA-LO

SKA-O

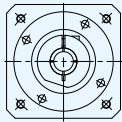

伺服馬達盤
請參考對應表選定

Please refer to the corresponding table to select the servo motor disk.

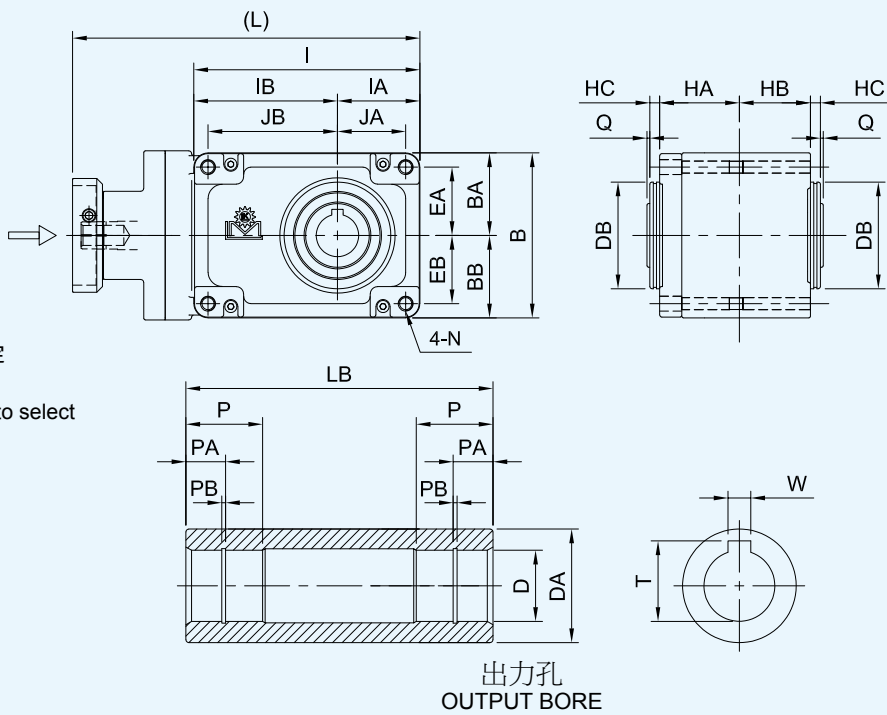

出力孔
OUTPUT BORE

伺服馬達盤對應表	
型號	適用馬達盤
09	F0
10	F1
11	F1
12	F2
13	F2 F3
14	F2 F3

SMALL GEAR REDUCER SERIES



S E R V O

最大容許扭力 Max. Permissible Toque

型號 Model No.	09	10	11	12	13	14
扭力 Torque kg-m	5	10	20	40	75	110

unit: mm

型號 Model	減速比 Ratio	JA	JB	I	IA	IB	EA	EB	B	BA
09	1/5~1/100(1/120)	38.5	68.5	127	48.5	78.5	38.5	38.5	97	48.5
10-S	1/5~1/40	43.5	76.5	139.5	53.5	86	43.5	43.5	107	53.5
10-L	1/50~1/200(1/240)	43.5	95.5	158.5	53.5	105	43.5	43.5	107	53.5
11-S	1/5~1/40	48	91	159	58	101	48	48	116	58
11-L	1/45~1/200(1/220~1/260)	46	110	180	58	122	46	46	116	58
12-S	1/5~1/40	56	105	185	68	117	56	56	136	68
12-L	1/50~1/200(1/225~1/250)	54	140	222	68	154	54	54	136	68
13-S	1/5~1/40	73	134	235	87	148	73	73	174	87
13-L	1/50~1/200(1/240~1/260)	69	167	272	87	185	69	69	174	87
14-S	1/5~1/40	102	170	304	118	186	90	90	212	106
14-L	1/50~1/160(1/180~1/285)	94	198	336	116	220	108	108	260	130

unit: mm

型號 Model	減速比 Ratio	BB	HA	HB	HC	Q	L	N
09	1/5~1/100(1/120)	48.5	47	31	7	2	197	M10
10-S	1/5~1/40	53.5	50	50	7	2	229	M10
10-L	1/50~1/200(1/240)	53.5	50	50	7	2	244	M10
11-S	1/5~1/40	58	56	50	7	2	244	M10
11-L	1/45~1/200(1/220~1/260)	58	56	50	7	2	265	M12
12-S	1/5~1/40	68	67.5	56.5	7	2	276	M12
12-L	1/50~1/200(1/225~1/250)	68	67.5	56.5	7	2	315	M16
13-S	1/5~1/40	87	85	65	7	2	F2 325 / F3 355	M16
13-L	1/50~1/200(1/240~1/260)	87	85	65	7	2	F2 365 / F3 395	M16
14-S	1/5~1/40	106	92.5	92.5	8	2	F2 416 / F3 446	M16
14-L	1/50~1/160(1/180~1/285)	130	92.5	92.5	8	2	F2 448 / F3 478	M20

unit: mm

型號 Model	減速比 Ratio	出力孔 Output Bore									重量 Weight (KG)
		D	DA	DB	W	T	P	PA	PB	LB	
09	1/5~1/100(1/120)	20	30	53	6	22.8	25	13	1.15	96	
10-S	1/5~1/40	25	40	66	8	28.3	30	14	1.35	118	
10-L	1/50~1/200(1/240)	25	40	66	8	28.3	30	14	1.35	118	
11-S	1/5~1/40	30	45	75	8	33.3	35	17	1.35	124	
11-L	1/45~1/200(1/220~1/260)	30	45	75	8	33.3	35	17	1.35	124	
12-S	1/5~1/40	35	50	85	10	38.3	40	20	1.75	142	
12-L	1/50~1/200(1/225~1/250)	35	50	85	10	38.3	40	20	1.75	142	
13-S	1/5~1/40	45	65	100	14	48.8	50	26	1.95	168	
13-L	1/50~1/200(1/240~1/260)	45	65	100	14	48.8	50	26	1.95	168	
14-S	1/5~1/40	55	80	120	16	59.3	60	32	2.2	205	
14-L	1/50~1/160(1/180~1/285)	55	80	120	16	59.3	60	32	2.2	205	



小型齒輪減速機系列

■ 同心軸戟齒減速機 - 伺服馬達用
Motor-Driver Hypoid Gear Reducer For Servo Motor(Concentric Shaft)

■ MODEL : SKA-SD / SKA-LD

SKA-D

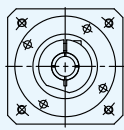

伺服馬達盤
請參考對應表選定

Please refer to the corresponding table to select the servo motor disk.

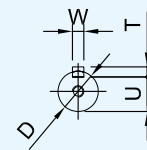
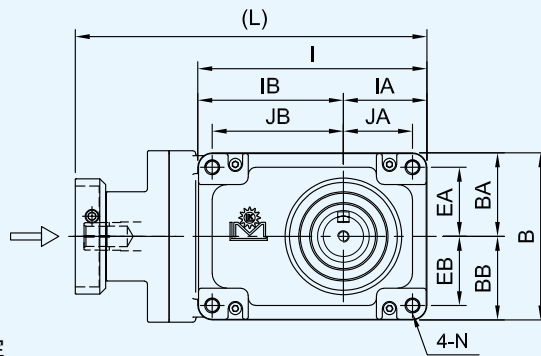

出力軸
OUTPUT SHAFT

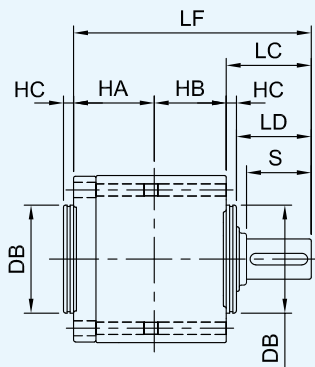

單軸
SINGLE SHAFT

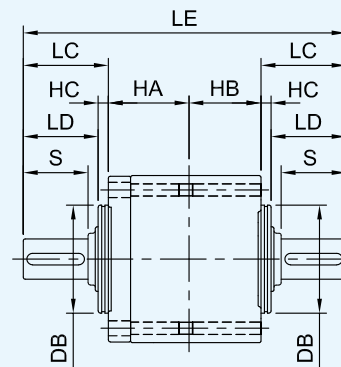

雙軸
DOUBLE SHAFT

伺服馬達盤對應表	
型號	適用馬達盤
09	F0
10	F1
11	F1
12	F2
13	F2 F3
14	F2 F3

SMALL GEAR REDUCER SERIES



S E R V O

最大容許扭力 Max. Permissible Toque						
型號 Model No.	09	10	11	12	13	14
扭力 Torque kg-m	5	10	20	40	75	110

unit: mm

型號 Model	減速比 Ratio	JA	JB	I	IA	IB	EA	EB	B
09	1/5~1/100(1/120)	38.5	68.5	127	48.5	78.5	38.5	38.5	97
10-S	1/5~1/40	43.5	76.5	139.5	53.5	86	43.5	43.5	107
10-L	1/50~1/200(1/240)	43.5	95.5	158.5	53.5	105	43.5	43.5	107
11-S	1/5~1/40	48	91	159	58	101	48	48	116
11-L	1/45~1/200(1/220~1/260)	46	110	180	58	122	46	46	116
12-S	1/5~1/40	56	105	185	68	117	56	56	136
12-L	1/50~1/200(1/225~1/250)	54	140	222	68	154	54	54	136
13-S	1/5~1/40	73	134	235	87	148	73	73	174
13-L	1/50~1/200(1/240~1/260)	69	167	272	87	185	69	69	174
14-S	1/5~1/40	102	170	304	118	186	90	90	212
14-L	1/50~1/160(1/180~1/285)	94	198	336	116	220	108	108	260

unit: mm

型號 Model	減速比 Ratio	BA	BB	HA	HB	HC	L	N
09	1/5~1/100(1/120)	48.5	48.5	47	31	7	197	M10
10-S	1/5~1/40	53.5	53.5	50	50	7	229	M10
10-L	1/50~1/200(1/240)	53.5	53.5	50	50	7	244	M10
11-S	1/5~1/40	58	58	56	50	7	244	M10
11-L	1/45~1/200(1/220~1/260)	58	58	56	50	7	265	M12
12-S	1/5~1/40	68	68	67.5	56.5	7	276	M12
12-L	1/50~1/200(1/225~1/250)	68	68	67.5	56.5	7	315	M16
13-S	1/5~1/40	87	87	85	65	7	F2 325 / F3 355	M16
13-L	1/50~1/200(1/240~1/260)	87	87	85	65	7	F2 365 / F3 395	M16
14-S	1/5~1/40	106	106	92.5	92.5	8	F2 416 / F3 446	M16
14-L	1/50~1/160(1/180~1/285)	130	130	92.5	92.5	8	F2 448 / F3 478	M20

unit: mm

型號 Model	減速比 Ratio	出力軸 Output Shaft										重量 Weight (KG)
		D	DB	S	W	T	U	LC	LD	LE	LF	
09	1/5~1/100(1/120)	18	53	30	6	6	14.5	42	35	162	120	
10-S	1/5~1/40	22	66	40	6	6	18.5	54	47	208	154	
10-L	1/50~1/200(1/240)	22	66	40	6	6	18.5	54	47	208	154	
11-S	1/5~1/40	28	75	45	8	7	24	59	52	224	165	
11-L	1/45~1/200(1/220~1/260)	28	75	45	8	7	24	59	52	224	165	
12-S	1/5~1/40	32	85	55	10	8	27	69	62	262	193	
12-L	1/50~1/200(1/225~1/250)	32	85	55	10	8	27	69	62	262	193	
13-S	1/5~1/40	40	100	65	12	8	35	79	72	308	229	
13-L	1/50~1/200(1/240~1/260)	40	100	65	12	8	35	79	72	308	229	
14-S	1/5~1/40	50	120	75	14	9	44.5	90	82	365	275	
14-L	1/50~1/160(1/180~1/285)	50	120	75	14	9	44.5	90	82	365	275	



小型齒輪減速機系列

■ 同心軸齒蝸減速機 - 伺服馬達用
Motor-Driver Worm Gear Reducer For Servo Motor(Concentric Shaft)

■ MODEL : SGWA-O

SGWA-O

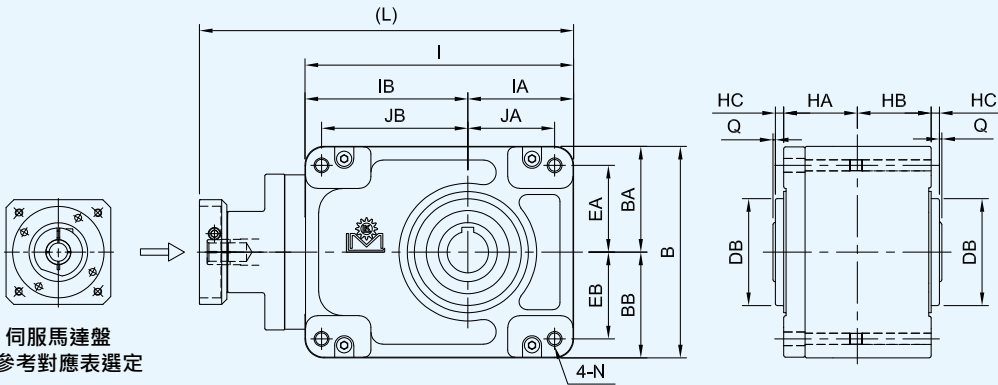

伺服馬達盤
請參考對應表選定

Please refer to the corresponding table to select the servo motor disk.

出力孔
OUTPUT BORE



S E R V O

伺服馬達盤對應表

型號	適用馬達盤
09	F0
10	F1
11	F1
12	F2
13	F2 F3
14	F2 F3

最大容許扭力 Max. Permissible Torque

型號 Model No.	09	10	11	12	13	14
扭力 Torque kg-m	5	10	20	40	75	110

unit: mm

型號 Model	減速比 Ratio	JA	JB	I	IA	IB	EA	EB	B	BA
09	1/10~1/290	38	70	128	48	80	38	38	96	48
10	1/20~1/240	47	88	159	59	100	47	47	118	59
11	1/20~1/290	58	106	187	70	117	58	58	140	70
12	1/20~1/300	73	123	226	89	137	73	73	178	89
13	1/10~1/310	88	150	278	108	170	88	88	216	108
14	1/10~1/200	105	182	337	130	207	105	105	260	130

unit: mm

型號 Model	減速比 Ratio	BB	HA	HB	HC	Q	L	N
09	1/10~1/290	48	46.5	33.5	6	2	197	M8
10	1/20~1/240	59	50	50	7	2	241	M10
11	1/20~1/290	70	59	47	7	2	269	M10
12	1/20~1/300	89	69	55	7	2	314	M12
13	1/10~1/310	108	85	65	7	2	F2 371 / F3 400	M16
14	1/10~1/200	130	101	80	10	2	F2 449 / F3 478	M20

unit: mm

型號 Model	減速比 Ratio	出力孔 Output Bore									重量 Weight (KG)
		D	DA	DB	W	T	P	PA	PB	LB	
09	1/10~1/290	20	30	70	6	22.8	25	13	1.15	96	
10	1/20~1/240	25	40	90	8	28.3	30	14	1.35	118	
11	1/20~1/290	30	45	90	8	33.3	35	17	1.35	124	
12	1/20~1/300	35	50	90	10	38.3	40	20	1.75	142	
13	1/10~1/310	45	65	100	14	48.8	50	26	1.95	168	
14	1/10~1/200	55	80	140	16	59.3	60	32	2.2	205	

■ 同心軸齒蝸減速機 - 伺服馬達用
Motor-Driver Worm Gear Reducer For Servo Motor(Concentric Shaft)

■ MODEL : SGWA-D

SGWA-D

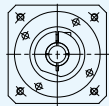

伺服馬達盤
 請參考對應表選定

Please refer to the corresponding table to select the servo motor disk.

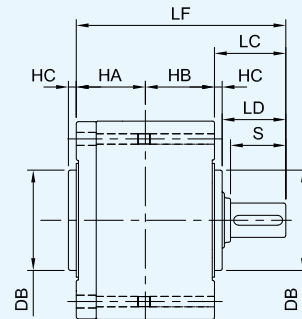
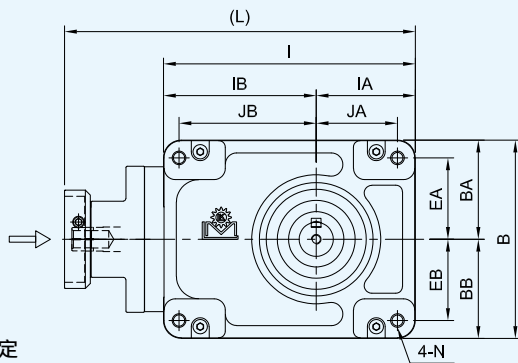

單軸
 SINGLE SHAFT

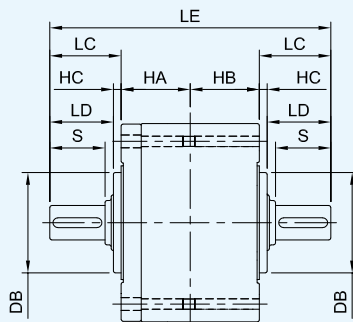

雙軸
 DOUBLE SHAFT

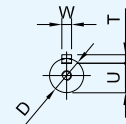

出力軸
 OUTPUT SHAFT



S E R V O

伺服馬達盤對應表

型號	適用馬達盤
09	F0
10	F1
11	F1
12	F2
13	F2 F3
14	F2 F3

最大容許扭力 Max. Permissible Torque

型號 Model No.	09	10	11	12	13	14
扭力 Torque kg-m	5	10	20	40	75	110

unit: mm

型號 Model	減速比 Ratio	JA	JB	I	IA	IB	EA	EB	B
09	1/10~1/290	38	70	128	48	80	38	38	96
10	1/20~1/240	47	88	159	59	100	47	47	118
11	1/20~1/290	58	106	187	70	117	58	58	140
12	1/20~1/300	73	123	226	89	137	73	73	178
13	1/10~1/310	88	150	278	108	170	88	88	216
14	1/10~1/200	105	182	337	130	207	105	105	260

unit: mm

型號 Model	減速比 Ratio	BA	BB	HA	HB	HC	L	N
09	1/10~1/290	48	48	46.5	33.5	6	197	M8
10	1/20~1/240	59	59	50	50	7	241	M10
11	1/20~1/290	70	70	59	47	7	269	M10
12	1/20~1/300	89	89	69	55	7	314	M12
13	1/10~1/310	108	108	85	65	7	F2 371 / F3 400	M16
14	1/10~1/200	130	130	101	80	10	F2 449 / F3 478	M20

unit: mm

型號 Model	減速比 Ratio	出力軸 Output Shaft										重量 Weight (KG)
		D	DB	S	W	T	U	LC	LD	LE	LF	
09	1/10~1/290	18	70	30	6	6	14.5	41	35	162	121	
10	1/20~1/240	22	90	40	6	6	18.5	54	47	208	154	
11	1/20~1/290	28	90	45	8	7	24	59	52	224	165	
12	1/20~1/300	32	90	55	10	8	27	69	62	262	193	
13	1/10~1/310	40	100	65	12	8	35	79	72	308	229	
14	1/10~1/200	50	140	75	14	9	44.5	92	82	365	273	

中空軸低背隙套件

Low Backlash Kit For Hollow Shaft



SLF □ - N

SK □ - N

機種型號表示 Indication of Model Numbers

SLF	□	10	— □	N	— 1/8	A	1/5
機型 Type SLF SK	機種 Type □: 無 None A: 伺服介面 Servo Type B: 自裝式 Motor-Driver D: 雙軸式 Double-Axle L: 多速比 High Reduction BL: 多速比自裝式 High Reduction Motor-Driver DL: 多速比雙軸式 High Reduction Double-Axle	型號 Model 09 10 11 12 13 14	法蘭型式 Flage Type □: 無 None S: 短框 Short Frame L: 長框 Long Frame	出力軸表示 Output N: 免鍵軸套 Clamping	馬力 Horse Power 1/8 HP 1/4 HP 1/2 HP 1 HP 2 HP 3 HP	馬達 Motor A: 三相 3-Phase B: 剎車 Brake C: 特殊 Special S: 單相 Single Phase	減速比 Ratio 1/5 ~ 1/2500 ※

※ 表中減速比以公稱速比，如需實際速比，請另告知。

The reduction ration in the table are nominal ratios. Please contact us if your need actual ratios.

■ 免鍵式軸套 (適用於 SLF-O / SK-SO / SK-LO 低背隙機種)
Clamping Sets (For SLF-O / SK-SO / SK-LO Low Backlash Models)

■ 背隙小於 15 弧分
Backlash ≤ 15 arcmin

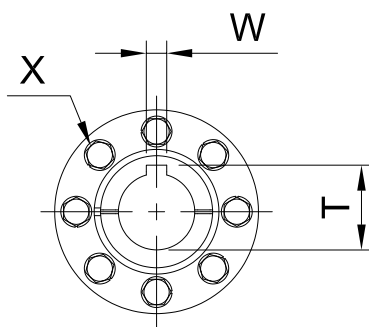
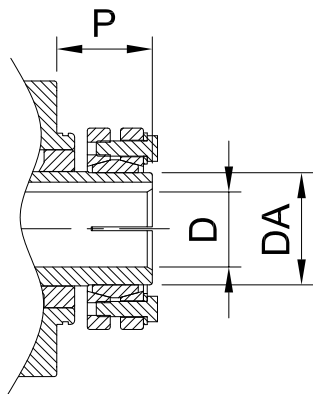

unit: mm

型號 Model	D	DA	P	W	T
10	25	34	35	8	28.2
11	30	44	37.5	8	33.3
12	35	44	37.5	10	38.2
13	45	60	44	14	48.8

注：其他相關尺寸參照各規格數據。
NOTE: For other related dimensions, please refer to the specifications.



迫緊片 B
Shrink Disc B



軸套
Bushing



迫緊片 A
Shrink Disc A



華司墊片
Washer



外六角螺栓
Outside Hexagon Bolt

型號 Model	螺絲規格 Spec. of Screw	螺絲強度等級 Screw Grade	螺絲鎖緊扭矩 Tighten Torque (Nm)	迫緊扭矩 Clench Torque (Nm)	螺絲數量 Quantity of Screw
10	M6	12.9	16.3	353.6	8
11	M6	12.9	16.3	735.75	8
12	M6	12.9	16.3	735.75	8
13	M8	12.9	41	882	8

馬達 kW 選定表扭力曲線圖

Motor kW Selection Table Torque Curve Drawing

- (1) 本選定表針對標準馬達（低壓三相全密式感應電動機。E 級絕緣）使用而言，對於起動頻繁、變動負載或衝擊負載等特殊負載條件者，不在此限。
- (2) 馬達所需 kW 以 $\frac{\text{必要負載轉矩}}{\text{效率}}$ 計算所得決定之
- 減速機效率 2 段減速時為 95%，3 段減速時為 92%。
 - 必要負載轉矩，如為變動負載以其等值轉矩表示之，如負載變動循環不明時，以最大轉矩使用之。
 - 一般對起動轉矩不予考慮。

選用例：

60Hz 地區所需低速軸回轉數 60RPM 負載最大轉矩 6kg-m

$$\frac{\text{負載轉矩}}{\text{效率}} = \frac{6}{0.95} = 6.3\text{Kg-m}$$

負載轉矩 6.3kg-m 之橫線與 60RPM 之垂直線之交點可得知馬達使用 0.4kW

計算值：

$$\text{馬達 kW} = \frac{6.3 \times 60}{974} = 0.39\text{kW}$$

0.39kW，可選用 1/2HP 馬達

$$\text{減速比} = \frac{\text{出力轉數}}{\text{馬達轉數}} = \frac{60}{1800} = \frac{1}{30}$$

(1) This selection table is for standard motor (low voltage 3-phase fully-enclosed induction motor, E class insulation). But it is exclusive for the conditions of frequent starting.

(2) kW required by the motor shall be decided from the calculation of

$$\frac{\text{Necessary Loading Torque}}{\text{Reducing Efficiency}}$$

The reducing efficiency of 2-stage reducer is 95%, and the reducing efficiency of 3-stage reduce is 92%.

Necessary loading torque, if the change loading is indicated by its equivalent value or if loading change cycle is unclear, please use the maximum torque.

In general, start torque won't be considered.

Example Of Selection:

60Hz district, low speed shaft required is 60 RPM, Maximum torque 6kg-m.

$$\frac{\text{Loading Torque}}{\text{Efficiency}} = \frac{6}{0.95} = 6.3\text{Kg-m}$$

From the cross point of the cross line of loading torque 6.3kg-m and the vertical line of 60RPM, we know the motor applied is 0.4kW.

Calculation value:

$$\text{Motor kW} = \frac{6.3 \times 60}{974} = 0.39\text{kW}$$

0.39kW can select to use of 1/2HP motor.

$$\text{Reducing Ratio} = \frac{\text{Output Revolving Speed}}{\text{Motor RPM}} = \frac{60}{1800} = \frac{1}{30}$$

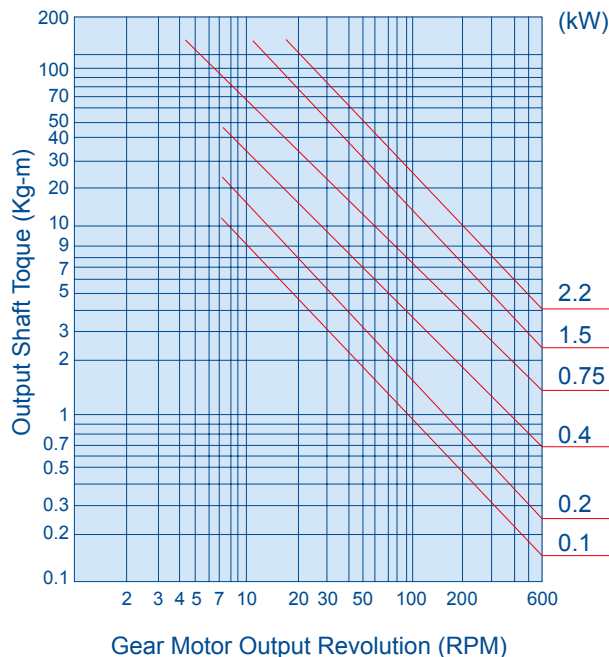

齒輪減速機性能表

Gear Reducer Performance Chart

減速比 Gear Ratio	出力軸回轉數 Output Shaft (RPM)		出力軸容許值 Permissible Value for Output Shaft																	
	50Hz	60Hz	0.1kW			0.2kW			0.4kW			0.75kW			1.5kW			2.2kW		
			Model	50Hz Kg-m	60Hz Kg-m	Model	50Hz Kg-m	60Hz Kg-m	Model	50Hz Kg-m	60Hz Kg-m	Model	50Hz Kg-m	60Hz Kg-m	Model	50Hz Kg-m	60Hz Kg-m	Model	50Hz Kg-m	60Hz Kg-m
1/3	465	570	10	0.17	0.13	10	0.3	0.25	11	0.75	0.6	12	1.6	1	12	2.5	2	13	4.0	3.5
1/5	300	360		0.3	0.25		0.6	0.5		1.2	1		2.3	1.9		4.5	3.7		6.7	5.6
1/10	150	180		0.6	0.5		1.2	1		2.4	2		4.5	3.8		9.0	7.5		13.4	11.2
1/15	100	120		0.9	0.75		1.8	1.5		3.6	3		6.9	5.7		13.6	11.3		20.0	16.8
1/20	75	90		1.2	1		2.4	2.0		4.8	4		9.1	7.5		18.0	15.1		26.8	22.4
1/25	60	72		1.5	1.2		3.0	2.5		6.0	5		11.3	9.4		22.6	18.9		33.6	28
1/30	50	60		1.8	1.5		3.6	3.0		7.2	6		13.6	11.3		27.2	22.6		40.0	33
1/40	37.5	45		2.3	1.9		4.6	3.9		9.3	7.8		17.5	14.6		35.0	29.1		52.0	43
1/50	30	36		2.9	2.4		5.8	4.8		11.6	9.7		21.9	18.3		43.7	36.4		65.0	54
1/60	25	30		3.5	2.9		7.0	5.8		14.0	11.6		26.3	21.9		52.0	43		-	67
1/75	20	24	4.4	3.6	8.7	7.3	17.5	14.6	32.9	27.4	66.0	55	-	84						
1/100	15	18	5.8	4.9	11.6	9.7	23.3	19.4	43.0	36	87.0	73	-	112						
1/120	12.5	15	7.0	5.8	14.0	11.6	28.0	23.3	52.0	43	-	88	-	134						
1/150	10	12	8.7	7.3	17.5	14.6	35.0	29.2	65.0	54	15	-	110	-	-					
1/200	7.5	9	11.6	9.7	23.0	19.1	43.0	36	78.0	73	-	147	-	-	-	-				

齒輪減速機標準馬達規格性能參考值

Specification & Performance Reference Value for Gear Reducer Motor

相數	馬力	周率	電壓
PHASE	HP	Hz	V
三相 3n	1/8HP(0.1kW)	50/60	220/380
	1/4HP(0.2kW)		
	1/2HP(0.4kW)		
	1HP(0.75kW)		
	2HP(1.5kW)		
	3HP(2.2kW)		

相數	馬力	周率	電壓
PHASE	HP	Hz	V
單相 1n	1/8HP(0.1kW)	50 60	220/380
	1/4HP(0.2kW)		
	1/2HP(0.4kW)		
	1HP(0.75kW)		
	2HP(1.5kW)		

註：1. 指定特殊異電壓，不適用上述規範參考值，另行設計。
2. 詳細數據請參考馬達銘牌。

NOTES:

- When the need arises to determine the special voltage frequency. Please contact the Li-Ming application engineering team.
- For detailed data, please refer to the motor nameplate.

■ 直流電磁停電剎車剖面構造圖 Cross Section of DC Mcgnetic Brake System

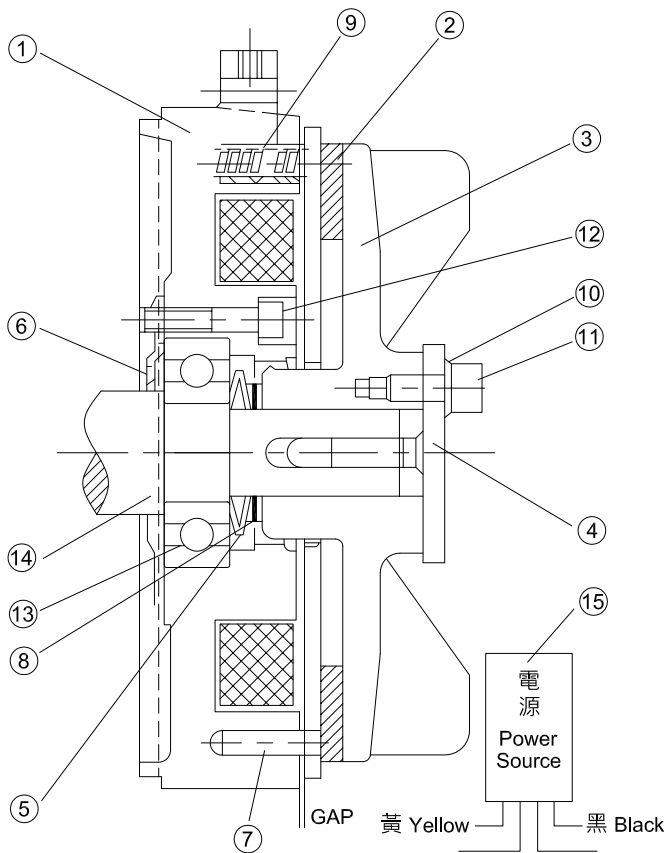

安裝條件 (一般標準品) Installation Condition (For Standard Product)			
周圍溫度	Ambient Temperature	-5C°~40C°	
周圍濕度	Ambient Humidity	85% 以下	Below 85%
周圍環境	Ambient Condition	避免腐蝕性，爆發性氣體，水蒸汽之環境，應置於乾燥且通風良好之環境	Please place in dry and well-ventilated location. Environment with corrosive gas, inflammable gas and moisture should be avoided
場所	Location	屋內，須裝置於平坦及堅固的底部	Indoor; the product should be installed on flat and solid foundation
機高	Elevation	1000m 以下	below 1000m

編號 NO.	零件名稱 Name of Parts	
1	托架 (附剎車線圈)	Bracket (Brake coil included)
2	剎車來令	Brake Shoe
3	外扇	Outer Fan
4	調整螺栓	Adjusting Screw
5	皿型彈簧	Tray-Type Spring
6	軸承蓋	Bearing Cover
7	彈簧銷	Spring Pin
8	墊圈	Washer
9	壓縮彈簧	Spring, Compression
10	彈簧墊圈	Washer For Spring
11	內六角螺絲	Hex. Screw
12	內六角螺絲	Hex. Screw
13	軸承	Bearing
14	馬達軸心	Motor Spindle
15	剎車電源裝置 (整流器)	Power Device For Brake (Rectifier)

剎車特性 Braking Characteristics										
出力	Force Output	(kW)	4 極	4-Pole	0.1	0.2	0.4	0.75	1.5	2.2
定柵制動	Actuation By Gradual Control	(kg-m)			0.1	0.2	0.4	0.75	1.5	2.2
釋放時間	Time of Releasing	(S)	交流一體切	Alternative Current Switch	0.1	0.07	0.10	0.12	0.14	0.15
			直流別切	Direct Current Switch	0.06	0.03	0.03	0.05	0.05	0.03
調整間隙	Clearance for Adjustment	(mm)	規定值	Specified Value	0.3	0.3	0.3	0.4	0.4	0.4
			限界值	Boundary Value	0.7	0.7	0.7	1.0	1.0	1.0

電源接線 Power Cable		
	電源接線 Power Cable	電源整流器裝置 Rectifier Device
交流一體切 Alternative Current Switch		1. 輸入 Input AC200V-50HZ AC200V-60HZ 輸出 Output DC90V 2. 單向 AC110V 使用全波整流器 One-Way AC 110 Full-Wave Rectifier 3. 異電壓 380V/440V 使用交流一體切時， 改變馬達接線方法 (接線盒圖所示) Voltage 380V/440V. Change motor connecting method when AC switch is used. (As indicated in figure of cable box.)
直流別切 Direct Current Switc		

電磁離合制動器剖面構造圖

Cross Section Structure of Electromagnetic Clutch Brake

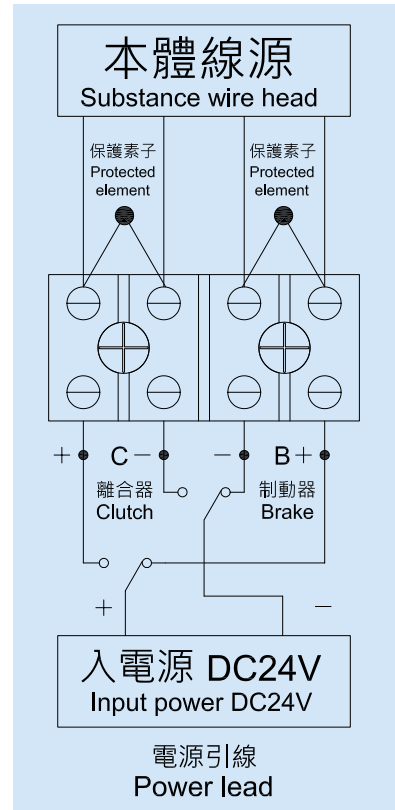
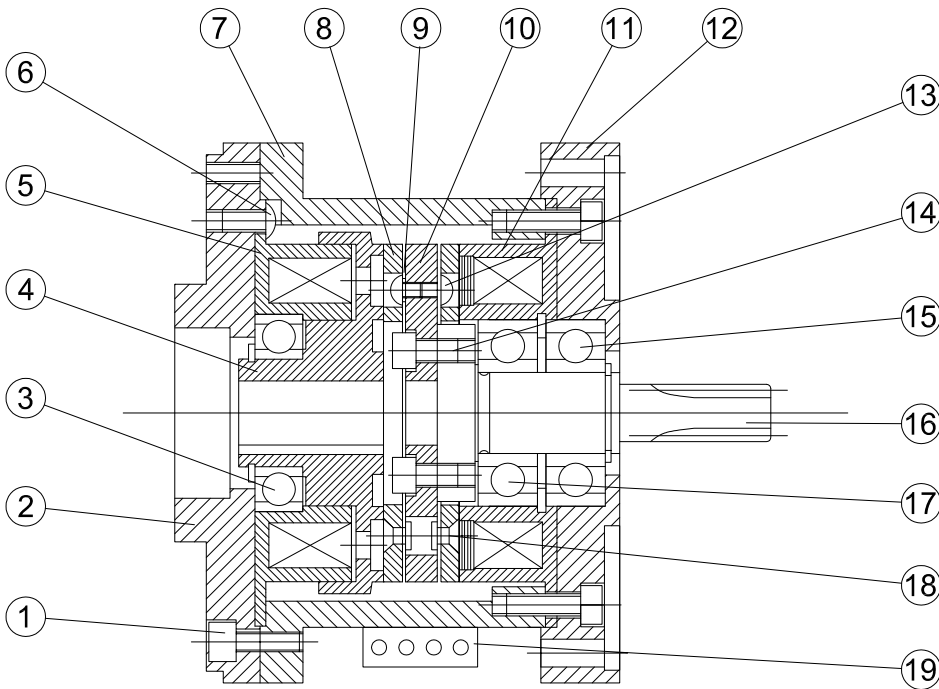

編號 NO.	零件名稱 Name of Parts	編號 NO.	零件名稱 Name of Parts
1	內六角螺絲 Hex. Screw	11	BT 磁極組 BF Magnetic Pole Section
2	法蘭面 (馬達端) Flange (Motor Point)	12	法蘭面 (減速機端) Flange (Decelerating Machine Point)
3	軸承 Bearing	13	圓頭內六角螺絲 Hex. Screw in the circle
4	CR 轉子 CR Rotor	14	內六角螺柱 Hex. Screw
5	CF 磁極組 CF Magnetic Pole Section	15	軸承 Bearing
6	圓頭內六角螺絲 Hex. Screw in the circle	16	軸心 Spindle
7	機體 Airframe	17	軸承 Bearing
8	電樞片 Leaf Electric Armature	18	鉚釘 Rivet
9	彈簧片 Leaf Spring	19	電源引線 DC24 Power Lead DC24
10	平板型導座 Conduct Base in Slab Type		

電磁離合器、制動器仕様 Electromagnetic Clutch, Types of Brack

離合器方式	Method of Clutch	幹式直六勵磁動作形	Dried Direct Current Exciter Action Form
電壓	Voltage	DC24V ± 10%	DC24V ± 10%
時間定格	Time Scale	連續	Continuity
絕緣體	Insulation	B 種	B kind
周圍溫度	Ambient Temperature	0°C ~ +40°C	0°C ~ +40°C
內襯材質	Internal Served Material	非石綿，低金屬	Non Asbestos, Low Metal
容許頻數	Allowed Frequency	80 回 / 分 (隨使用條件而變)	80 times/minute (Depends on used Condition)

電磁離合器、制動器特性 Electromagnetic Clutch, Features of Brack

規格出力 Force Output Specifications (kg)	動摩擦 Moving Friction (kgfm)	電壓 Voltage (DCV)	容量 Capacity (W)	電流 Electric Current (A)	電樞吸引時間 Engaged Time of Electric Armature (ms)	電樞釋放時間 Released Time of Electric Armature (ms)	保護素子 Protected Element	調整間隙 Clearance for Adjustment (mm)
0.1	0.50	24	11	0.46	13	12	TNR9G820K	0.2±0.05
0.2	0.50	24	11	0.46	13	12	TNR9G820K	0.2±0.05
0.4	1.00	24	15	0.63	21	15	TNR9G820K	0.2±0.05

齒輪減速機一般故障原因及改善方法 Solutions and Reasons for The Genral Faults of Reduction Gears

故障情況 Fault Description	故障原因 Reasons	解決方法 Solutions
減速機過熱 Overheation	★超負荷運轉 Overload.	★調整至適當負荷 Adjust to proper loading.
	★油封過度磨擦 Over friction of oil seal.	★在油封處滴潤滑油 Drop lubricant at oil seal.
	★出力軸與傳動裝置連接不當 Improper connection between driving shaft and the transmission device.	★調整至適當位置 Adjust to proper position.
	★衝擊荷重大 Large impact loading.	★更換較大型號減速機 Use larger reduction gears.
減速機雜音 Noise	★超負荷運轉 Overload.	★調整至適當負荷 Adjust to proper loading.
	★軸承損傷或間隙過大 Bearing damaged or too large clearance.	★更換軸承 Replace bearing.
	★潤滑油不足或劣化 Lubricant oil shortage or deterioration.	★依指示加入適量潤滑油 Fill in adequate lubricant oil as indication.
	★出力軸與傳動裝置連接不當 Improper connection between driving shaft and the transmission device.	★調整至適當位置 Adjust to proper position.
	★螺栓鬆脫 Bolt loose.	★旋緊螺栓 Tighten bolt.
	★傳動裝置固定不良 Improper installation of transmission device.	★傳動裝置固定 Fix transmission device properly.
漏油 Oil Leakage	★油封損傷 Oil seal damaged.	★更換油封 Replace oil seal.
	★油量過多 Too much oil.	★依指示加入適量潤滑油 Fill in adequate lubricant oil as indication.
	★螺絲鬆脫 Screw loose.	★旋緊螺絲 Tighten screw.
	★外殼破裂 Outside shell fractured.	★更換外殼 Replace outer shell.
出力軸不轉 Driving Shaft Cannot Rotate	★超負荷運轉 Overload.	★調整至適當負荷 Adjust to proper loading.
	★軸承損傷 Bearing damaged.	★更換軸承 Replace bearing.
	★異物嵌入 Invasion by foreign objects.	★取出異物 Take out foreign objects.
	★齒輪磨損 Gear worn-out	★更換齒輪 Replace gear.
	★馬達損壞 Motor out of order.	★修復馬達 Repair motor.
	★配線錯誤 Incorrect wiring.	★依指示配線 Wiring as indication.
	★衝擊荷重過大	★更換較大型號減速機 Use larger reduction gears.

注：

1. 以上所列为一般故障原因，如有其它故障情形時，請與本公司聯絡，我們將會提供最正確之服務。
2. 產品如經自行拆裝或更改，產生異常本公司恕不負責。

NOTES :

- 1.The above items are general fault descriptions. In case of other kinds of faults, please contact with us to obtain most correct services.
- 2.If the product has been broken off or changed, the unusual matter the company won't be in charge of the case.

安裝條件 (一般標準品) Installation Condition (For Standard Product)		
周圍溫度	Ambient Temperature	-5°C ~ 40°C
周圍濕度	Ambient Humidity	85% 以下 Below
周圍環境	Ambient Condition	避免腐蝕性，爆發性氣體，水蒸氣之環境，應置於乾燥且通風良好之環境。 Please place in dry and well-ventilated location. Environment with corrosive gas, inflammable Gas and moisture should be avoided.
場所	Location	屋內，須裝置於平坦及堅固之底部。 Indoor; the product should be installed on flat and solid foundation.
標高	Elevation	1000m 以下 below

減速機規格 Specifications of Reduction Gear		
齒輪材料 出力軸材料	Gear Material Material of Outlet Axle	S45C(高週波) / SCM415(滲碳) / SCM440(氮化) S45C(High-frequency Wave) / SCM415(Carbonization) / SCM440(Nitrogen Hardening)
潤滑方式	Lubrication	Grease NO.0
外殼	Shell	鋁合金 (ADC12) / 鑄鐵 (FC20) / 鋁合金 (A380) Aluminum Alloy(ADC12) / Cast Iron(FC20)

馬達規格 Motor of Reduction Gear					
相數	Phase No	三相	3-phase	單相	Single-phase
外被構造	Enclosure Structure	全閉外扇 (0.1kW~2.2kW)	Closed with External-fan (0.1kW~2.2kW)	全閉外扇 (0.1kW~2.2kW)	Closed with External-fan (0.1kW~2.2kW)
啟動方式	Start-up Method	直接啟動	Direct	電容運轉 電容啟動運轉	Capacitor Capacitor Motor (Variable Capacitor)
頻率	Frequency	50HZ / 60HZ		50HZ / 60HZ	
電壓	Voltage	415V 220 / 380V	460V 220 / 440V	110 / 220V	
時間定格	Time Scale	連續	Continuous	連續	Continuous
極數	Pole No	4極	Four	4極	Four
絕緣	Insulation	E級	E Grade	E級	E Grade



■ 特殊用途減速機 Special Purpose Speed Reducer



SH 電磁離合剎車 DC24V
SH Electromagnetic
Clutch Brake DC24V



SV 電磁離合剎車 DC24V
SV Electromagnetic
Clutch Brake DC24V



SMW 電磁離合剎車 DC24V
SMW Electromagnetic
Clutch Brake DC24V



SEOM 電磁離合剎車 DC24V
SEOM Electromagnetic
Clutch Brake DC24V



SH 手釋放剎車
SH Released Brake



SV 手釋放剎車
SV Released Brake



SNEOVM 手釋放剎車
SNEOVM Released Brake



SH 變頻馬達加獨立風扇
SH Frequency Conversion Motor
Plus an Independent Ventilator



SVL 法蘭面凸托架剔平免風葉、風罩
SVL Sharpen Flange Raised
Bracket, without Air Blade and Air Lid



出力軸裝電磁離合器 DC24V
Force Output Axle Installation
Electromagnetic Clutch DC24V



SV 出力軸含齒輪
SV Output Shaft with Gear



SAMW60 (1/100 以上)



SVOM70 (1/100 以上)



SMWT



SVTMD



SEOWY

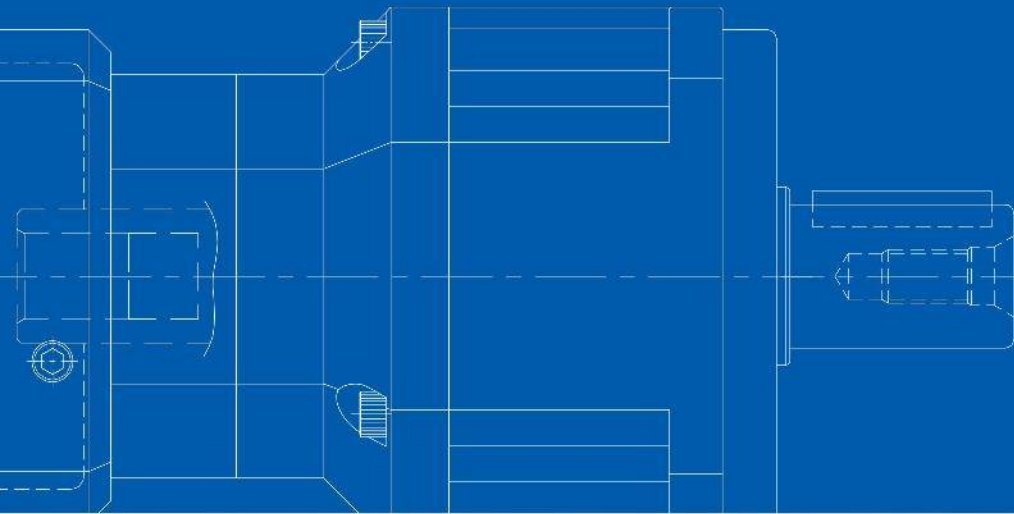

High Accuracy & Efficiency Profit



**MEXICO
BRANCH OFFICE**

Roberto Diaz No. 401
Ciudad Industrial
Aguascalientes, Ags.
México
20290

4ManPro@4ManPro.com

+52 (449) 171 3420
www.4ManPro.com/SPA/

**USA
BRANCH OFFICE**

708 Main St.
10th Floor
Houston, Tx, USA
77002

[4ManPro_USA
@4ManPro.com](mailto:4ManPro_USA@4ManPro.com)

+1 (832) 871 5022
www.4ManPro.com/ENG/

